

TECHNICAL DATA SHEET

DESCRIPTION

The Dayton Superior T46 & T46HD Ground Release II Spreader Beam is supplied with two 8-1/2 ton shackles to attach the beam to two ground release inserts.

APPLICATION

The T46 & T46HD are used to simplify rigging change requirements on large or extremely heavy panels.

MANUFACTURER

Dayton Superior Corporation
 1125 Byers Road
 Miamisburg, OH 45342
 Customer Service: 888-977-9600
 Technical Services: 877-266-7732
 Website: www.daytonsuperior.com

WARRANTY (ACCESSORIES)

Limited Warranty. Dayton warrants, for a period of 60 days from the date of shipment (three years from the date of shipment in the case of formwork, excluding any consumable Products included with such formwork), that Products and any associated application drawings and engineering services provided by Dayton ("Ancillary Services") will be free from defects in material and workmanship and, in the case of custom designed formwork, that the formwork will meet the specifications set forth in the design drawings approved by Dayton and Customer. Any claim under this warranty must be made in writing within such warranty period. If any Product and/or Ancillary Service covered by a timely claim are found to be defective, Dayton will, within a reasonable time, make any necessary repairs or corrections or, at Dayton's option, replace the Product. Unless pre-authorized by Dayton in writing, Dayton will not accept any charges for correcting defects or accept the return of any Product. This warranty will not apply to any Products that have been subjected to misuse, neglect, storage damage, misapplication, accident or any other damage caused by any person other than Dayton, or that have not been maintained in accordance with Dayton's specifications. THIS LIMITED WARRANTY IS IN LIEU OF ALL OTHER WARRANTIES AS TO THE PRODUCTS AND ANCILLARY SERVICES. DAYTON MAKES NO OTHER WARRANTIES OR GUARANTEES, EXPRESS OR IMPLIED, INCLUDING ANY WARRANTY OF MERCHANTABILITY, FITNESS FOR A PARTICULAR PURPOSE OR OTHERWISE. THE REMEDIES SET FORTH IN THIS SECTION ARE CUSTOMER'S EXCLUSIVE REMEDY FOR BREACH OF WARRANTY.

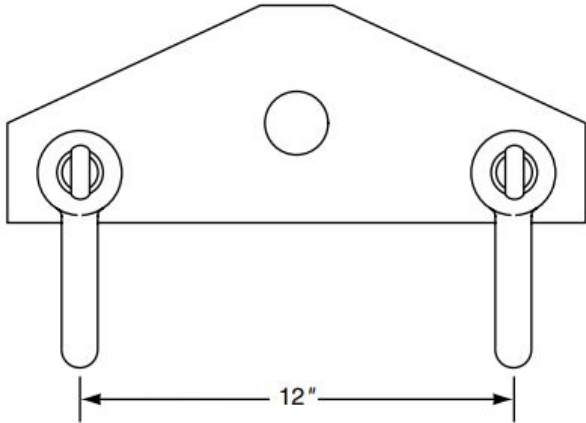

T46 Ground Release^{II} Spreader Beam with Twin Shackles

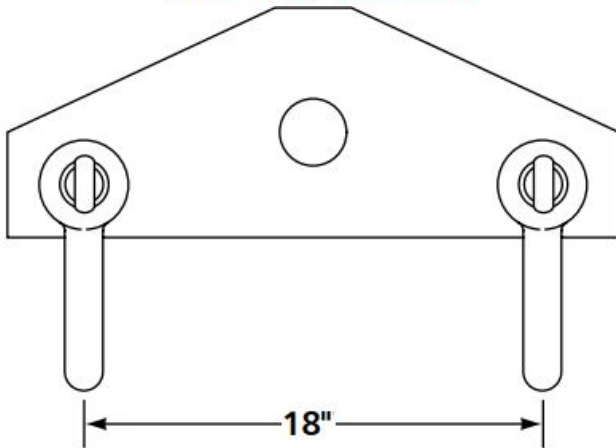

T46HD Ground Release^{II} Spreader Beam with Twin Shackles

FEATURES

- The T46 and T46HD have an approximate safety factor of 5 to 1
- T46- Safe Working Load of 30,000 lbs.
- T46HD- Safe Working Load of 32,000 lbs.

RELATED PRODUCTS

- T110 Superior Lift System
- T275 Tilt-Up Anchor
- T42 Double Ground Release II System