

TECHNICAL DATA SHEET

DESCRIPTION

The Dayton Superior P96 Fleet-Lift Two-Hole Anchors are specifically designed for lifting and handling precast concrete elements.

APPLICATION

The Dayton Superior P96 Fleet-Lift Two-Hole Anchor is always used in conjunction with the Dayton Superior P98T Tension Bar

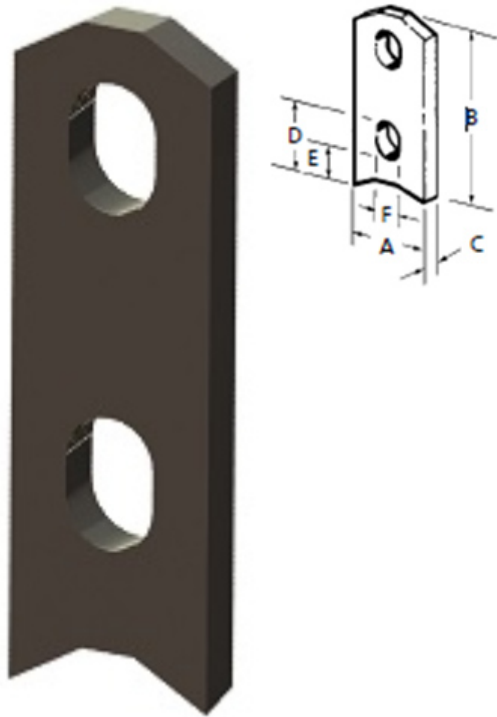

FEATURES

- The tension bar distributes the tension forces, developed from the lifting process, deep into the precast concrete. This allows the lifting of very thin and/or low concrete compressive strength panels.
- Do not use this anchor without a correctly sized and located tension bar.
- Do not use this anchor in the edge of thin panels where shear loads will be applied to the anchor.

TECHNICAL DATA

P96 - Fleet-Lift Two-Hole Anchors

Ton x Length	Tension SWL w/ Tension Bar	A	B	C	D	E	F
2-ton x 2-3/4" long	4,000 lbs	1-1/4"	2-3/4"	3/8"	9/16"	15/16"	9/16"
2-ton x 4" long	4,000 lbs	1-1/4"	4"	3/8"	3/4"	7/8"	9/16"
4-ton x 5-1/2" long	8,000 lbs	1-1/2"	5-1/2"	5/8"	7/8"	1"	11/16"
8-ton x 7" long	16,000 lbs	2-1/2"	7"	3/4"	1-3/16"	1-1/2"	1"

INSTALLATION

1. The anchor has a bottom hole especially designed to accept the tension bar.
2. Place the P98T Tension Bar through the bottom hole in such a manner that the ends of the tension bar are pointing downward.
3. Fasten the tension bar tight against the bottom side of the hole.

RELATED PRODUCTS

- P98T Fleet-Lift Tension Bar

ORDERING INFORMATION

FLEET LIFT™ TWO-HOLE ANCHOR

Product Code	Description	Weight
FL122	P92H 2 TON 4.00" PLAIN	0.420 LB
FL122G	P92H 2 TON 4.00" HDGALV	0.420 LB
FL124	P92H 4 TON 5.50" PLAIN	1.230 LB
FL124G	P92H 4 TON 5.50" HDGALV	1.230 LB
FL125	P92H 8 TON 7.00" PLAIN	3.310 LB
FL125G	P92H 8 TON 7.00" HDGALV	3.000 LB

MANUFACTURER

Dayton Superior Corporation
 1125 Byers Road
 Miamisburg, OH 45342
 Customer Service: 888-977-9600
 Technical Services: 877-266-7732
 Website: www.daytonsuperior.com

TECHNICAL DATA SHEET**WARRANTY (ACCESSORIES)**

Limited Warranty. Dayton warrants, for a period of 60 days from the date of shipment (three years from the date of shipment in the case of formwork, excluding any consumable Products included with such formwork), that Products and any associated application drawings and engineering services provided by Dayton ("Ancillary Services") will be free from defects in material and workmanship and, in the case of custom designed formwork, that the formwork will meet the specifications set forth in the design drawings approved by Dayton and Customer. Any claim under this warranty must be made in writing within such warranty period. If any Product and/or Ancillary Service covered by a timely claim are found to be defective, Dayton will, within a reasonable time, make any necessary repairs or corrections or, at Dayton's option, replace the Product. Unless pre-authorized by Dayton in writing, Dayton will not accept any charges for correcting defects or accept the return of any Product. This warranty will not apply to any Products that have been subjected to misuse, neglect, storage damage, misapplication, accident or any other damage caused by any person other than Dayton, or that have not been maintained in accordance with Dayton's specifications. THIS LIMITED WARRANTY IS IN LIEU OF ALL OTHER WARRANTIES AS TO THE PRODUCTS AND ANCILLARY SERVICES. DAYTON MAKES NO OTHER WARRANTIES OR GUARANTEES, EXPRESS OR IMPLIED, INCLUDING ANY WARRANTY OF MERCHANTABILITY, FITNESS FOR A PARTICULAR PURPOSE OR OTHERWISE. THE REMEDIES SET FORTH IN THIS SECTION ARE CUSTOMER'S EXCLUSIVE REMEDY FOR BREACH OF WARRANTY.