

TECHNICAL DATA SHEET

DESCRIPTION

The P92SF Forged Sandwich Panel Erection Anchor is designed to erect precast insulated sandwich panels with a minimum loss of insulation. The P92SF Sandwich Panel Erection Anchor is designed for use with the most common insulation thickness. The head of the anchor is designed with two protrusions on the head of the anchor which provide protection against concrete spalling. These protrusions restrict the ring clutch rotation during lateral pulls. As a result, lateral forces are transmitted directly to the edge of the anchor instead of the concrete. The design of the anchor allows it to distribute anchor loads evenly to both concrete wythes. This is accomplished by the use of two tension bars placed through the holes at the end of the anchor.

Due to the anchor being forged, it does not depend on welds or thread engagement to develop its safe working load. Forging provides maximum safety with its advantageous material structure. This allows the anchor to easily meet the OSHA requirement of 4 to 1 factor of safety.

APPLICATION

The P92SF is installed in concrete for tension and shear lifting applications.

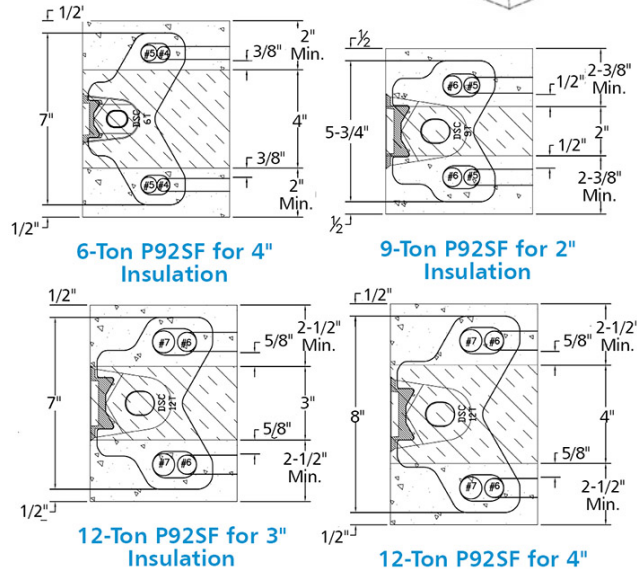
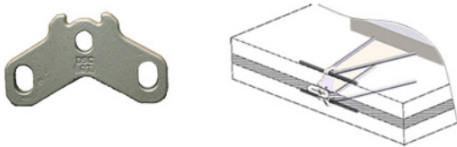

FEATURES

- Patent #5,857,296
- Forged design creates up to 33% higher load capacity than stamped anchors which can reduce the number of anchors required.
- Plain or galvanized finishes available. Meets non-rusting requirements.
- Forged material minimizes rust and can result in eliminating galvanizing requirement for some projects.
- Design eliminates steel near top edge of face of panel, reducing opportunity of crack occurring.
- Two tension bars must be used with the sandwich panel erection anchor to achieve the safe working loads shown.
- Based on Charpy Impact Test, forged anchors have twice low temperature ductility over stamped anchors.

Tech Data

Safe Working Load is based on 4:1 safety factor.

Anchor Tonnage	Anchor Length	Insulated Panel Thickness	Shear Parallel to Thickness (lb)	Shear Perpendicular to Thickness (lb)	Tension (lb)	Tension Rebar	Shear Rebar
6 ton	7"	2"x4"x2"	2,675	8,200	12,000	#4x34" Gr. 60	#5x6" Gr.60
		3"x3"x3"	4,500	9,600			
9 ton	5.75"	3"x2"x3"	4,400	8,700	18,000	#5x42" Gr. 60	#6x6" Gr. 60
		4"x2"x2"	4,600	9,260			
12 ton	7"	3"x3"x3"	4,700	10,900	24,000	#6x66" Gr. 60	#7x6" Gr. 60
12 ton	8"	3"x4"x3"	4,400	9,200	24,000	#6x66" Gr. 60	#7x6" Gr. 60

6 ton and 9 ton concrete strength is 3,500 psi. 12 ton concrete strength is 4,500 psi.

INSTALLATION

1. Place one configured tension bar through the holes of the anchor extending from the anchor into the top and bottom wythe of concrete.
2. Place shear bars through top of tension bar slot next to tension bars.

RELATED PRODUCTS

- P91S Ring Clutch
- P99 Fleet-Lift Reusable Recess Plug
- P99C Fleet-Lift Cast Steel Recess Plug
- P99D Fleet-Lift Disposable Recess Plug
- FL131 Fleet-Lift Holding Rod
- P92T Tension Bars

TECHNICAL DATA SHEET

HOW TO ORDER

Specify: (1) Quantity, (2) Name, (3) Product Code, (4) Finish

ORDERING INFORMATION

FLEET LIFT™ FORGED SANDWICH PANEL ERECTION

ANCHOR - N/A

Product Code	Description	Weight
143700	6 TON 7.00" PLAIN	2.700 LB
145081	9 TON 5.75" PLAIN	3.242 LB
145572	12 TON 7.00" PLAIN	4.100 LB
145573	12 TON 8.00" PLAIN	4.770 LB
143701	6 TON 7.00" HOT DIPPED GALV.	2.700 LB
145719	12 TON 8.00" HOT DIPPED GALV.	4.800 LB

MANUFACTURER

Dayton Superior Corporation
 1125 Byers Road
 Miamisburg, OH 45342
 Customer Service: 888-977-9600
 Technical Services: 877-266-7732
 Website: www.daytonsuperior.com

WARRANTY (ACCESSORIES)

Limited Warranty. Dayton warrants, for a period of 60 days from the date of shipment (three years from the date of shipment in the case of formwork, excluding any consumable Products included with such formwork), that Products and any associated application drawings and engineering services provided by Dayton ("Ancillary Services") will be free from defects in material and workmanship and, in the case of custom designed formwork, that the formwork will meet the specifications set forth in the design drawings approved by Dayton and Customer. Any claim under this warranty must be made in writing within such warranty period. If any Product and/or Ancillary Service covered by a timely claim are found to be defective, Dayton will, within a reasonable time, make any necessary repairs or corrections or, at Dayton's option, replace the Product. Unless pre-authorized by Dayton in writing, Dayton will not accept any charges for correcting defects or accept the return of any Product. This warranty will not apply to any Products that have been subjected to misuse, neglect, storage damage, misapplication, accident or any other damage caused by any person other than Dayton, or that have not been maintained in accordance with Dayton's specifications. THIS LIMITED WARRANTY IS IN LIEU OF ALL OTHER WARRANTIES AS TO THE PRODUCTS AND ANCILLARY SERVICES. DAYTON MAKES NO OTHER WARRANTIES OR GUARANTEES, EXPRESS OR IMPLIED, INCLUDING ANY WARRANTY OF MERCHANTABILITY, FITNESS FOR A PARTICULAR PURPOSE OR OTHERWISE. THE REMEDIES SET FORTH IN THIS SECTION ARE CUSTOMER'S EXCLUSIVE REMEDY FOR BREACH OF WARRANTY.