

## TECHNICAL DATA SHEET

### DESCRIPTION

The P91S Fleet-Lift Ring Clutch consists of a clutch body, a curved bolt and a high strength bail.

### APPLICATION

P91S Ring Clutch is used with Fleet Lift Anchor for lifting and handling of precast concrete panels.

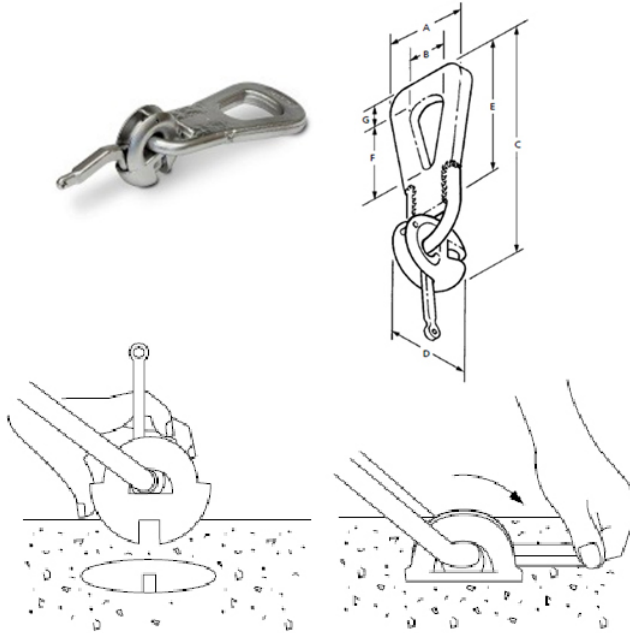

### FEATURES

- Installation and release of P91S is safe and simple.
- After the clutch is inserted over the anchor head and into the recess, the curved bolt is rotated into the closed position. Rotation of the standard bail is a full 360°.
- Once engaged and supporting 400 lbs of load, the ring clutch cannot be released.
- Made with electro galvanized finish per ASTM B633 SC1 Type III

### TECHNICAL DATA

SWL	Load (Tons)	PCN	A	B	C	D	E	F	G
3	2-3	FL001S	3-3/4"	2-3/8"	10-1/2"	3"	7"	3"	1"
6	4-6	FL002S	4-3/4"	2-5/8"	12-1/2"	4"	8-1/4"	3-1/2"	1-1/2"
12	8-12	FL003S	5-7/8"	3"	17-3/4"	5-7/8"	11"	4-1/2"	2-1/8"

Safe Working Load provides a factor of safety of approximately 5 to 1.

### INSTALLATION

1. The P91S Ring Clutch is located directly over the head of a Fleet-Lift Anchor.
2. The ring clutch is pushed down onto the anchor head and the curved bolt is rotated through the engagement hole of the anchor and locked into position. The process of engaging anchor and ring clutch is completed in seconds.
3. To disengage the anchor and ring clutch, simply pull the curved bolt free of the anchor. This allows the ring clutch to be easily removed from the head of the anchor.
4. Dayton Superior recommends a minimum 3/4" cover between the bottom of an anchor and the concrete surface. This minimum recommended concrete cover is to prevent anchor corrosion.

### RELATED PRODUCTS

- Fleet-Lift Anchors
- P99 Fleet-Lift Reusable Recess Plug
- P99C Fleet-Lift Cast Steel Recess Plug
- P99D Fleet-Lift Disposable Recess Plug (PVC)

### ORDERING INFORMATION

#### STANDARD

Product Code	Description	Weight
FL001S	2-3 TON 10.38"	3.875 LB
FL002S	4-6 TON 12.5"	9.05 LB
FL003S	8-12 TON 16.5"	23.2 LB

### MANUFACTURER

Dayton Superior Corporation  
 1125 Byers Road  
 Miamisburg, OH 45342  
 Customer Service: 888-977-9600  
 Technical Services: 877-266-7732  
 Website: [www.daytonsuperior.com](http://www.daytonsuperior.com)

**TECHNICAL DATA SHEET****WARRANTY (ACCESSORIES)**

Limited Warranty. Dayton warrants, for a period of 60 days from the date of shipment (three years from the date of shipment in the case of formwork, excluding any consumable Products included with such formwork), that Products and any associated application drawings and engineering services provided by Dayton ("Ancillary Services") will be free from defects in material and workmanship and, in the case of custom designed formwork, that the formwork will meet the specifications set forth in the design drawings approved by Dayton and Customer. Any claim under this warranty must be made in writing within such warranty period. If any Product and/or Ancillary Service covered by a timely claim are found to be defective, Dayton will, within a reasonable time, make any necessary repairs or corrections or, at Dayton's option, replace the Product. Unless pre-authorized by Dayton in writing, Dayton will not accept any charges for correcting defects or accept the return of any Product. This warranty will not apply to any Products that have been subjected to misuse, neglect, storage damage, misapplication, accident or any other damage caused by any person other than Dayton, or that have not been maintained in accordance with Dayton's specifications. THIS LIMITED WARRANTY IS IN LIEU OF ALL OTHER WARRANTIES AS TO THE PRODUCTS AND ANCILLARY SERVICES. DAYTON MAKES NO OTHER WARRANTIES OR GUARANTEES, EXPRESS OR IMPLIED, INCLUDING ANY WARRANTY OF MERCHANTABILITY, FITNESS FOR A PARTICULAR PURPOSE OR OTHERWISE. THE REMEDIES SET FORTH IN THIS SECTION ARE CUSTOMER'S EXCLUSIVE REMEDY FOR BREACH OF WARRANTY.