

TECHNICAL DATA SHEET

DESCRIPTION

The P91NC Fleet-Lift Cable Bail Ring Clutch consists of a clutch body, a clutch handle, high strength eyelet, and high strength cable.

APPLICATION

The P91NC Cable Bail Ring Clutch is used with Fleet-Lift Anchors for lifting and handling of precast concrete panels.

PRODUCT SPECIFICATION

- Fits all Fleet-Lift Anchors in the DSC Product Line
- Three different sizes are available: Rated for 1-3 Ton, 4-6 Ton, & 8-12 Ton
- Safety Factor of 5:1



BENEFITS

- Easy to identify and recognize with the Dayton Superior blue painted on the eyelet thimble
- Longer life span of cable use due to the eyelet thimble feature that reduces the stress and wear on the cable over time

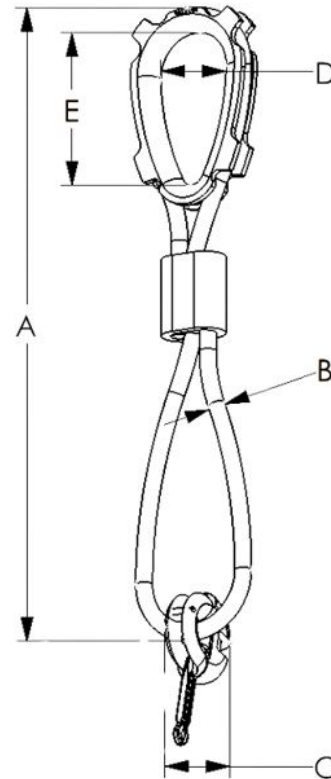

TECHNICAL DATA

Safe working load provides a factor of safety of approximately 5 to 1.

Safe Working Loads (Tons)	Load Range (Tons)	Product Code	A	B	C	D	E
3	1-3	FL004 NC	24"	14 mm	3.085"	2-3/8"	4-3/8"
6	4-6	FL005 NC	26"	18 mm	4.025"	3-3/8"	6-5/8"
12	8-12	FL006 NC	32"	26 mm	5.888"	3-3/4"	7-1/8"

INSTALLATION

1. The P91NC Cable Bail Ring Clutch is located directly over the head of a Fleet-Lift Anchor.
2. The ring clutch is pushed down onto the anchor head and the curved bolt is rotated through the engagement hole of the Anchor and locked into position. The process of engaging anchor and ring clutch is completed in seconds.
3. Once the load is relaxed, disengage the anchor and ring clutch by pulling the curved bolt free of the anchor. This allows the ring clutch to be easily removed from the head of the anchor.
4. Dayton Superior recommends a minimum 3/4" cover between the bottom of an anchor and the concrete surface. This minimum recommended concrete cover is to prevent anchor corrosion.

TECHNICAL DATA SHEET

RELATED PRODUCTS

- Fleet-Lift™ Anchors
- P99 Fleet-Lift™ Reusable Recess Plug
- P99C Fleet-Lift™ Cast Steel Recess Plug
- P99D Fleet-Lift™ Disposable Recess Plug (PVC)

HOW TO ORDER

To Order:
Specify: (1) quantity, (2) name, (3) product code, (4) system size.

Example:
9, P91NC Fleet-Lift Cable Bail Ring Clutches, FL004NC, 4-6 Ton units.

ORDERING INFORMATION

FLEET LIFT™ RING CLUTCH WITH CABLE BALL

Product Code	Description	Weight
FL004NC	1-3 TON 24"	7.04 LB
FL005NC	4-6 TON 26"	14.29 LB
FL006NC	8-12 TON 32"	35.24 LB

MANUFACTURER

Dayton Superior Corporation
1125 Byers Road
Miamisburg, OH 45342
Customer Service: 888-977-9600
Technical Services: 877-266-7732
Website: www.daytonsuperior.com

WARRANTY (ACCESSORIES)

Limited Warranty. Dayton warrants, for a period of 60 days from the date of shipment (three years from the date of shipment in the case of formwork, excluding any consumable Products included with such formwork), that Products and any associated application drawings and engineering services provided by Dayton ("Ancillary Services") will be free from defects in material and workmanship and, in the case of custom designed formwork, that the formwork will meet the specifications set forth in the design drawings approved by Dayton and Customer. Any claim under this warranty must be made in writing within such warranty period. If any Product and/or Ancillary Service covered by a timely claim are found to be defective, Dayton will, within a reasonable time, make any necessary repairs or corrections or, at Dayton's option, replace the Product. Unless pre-authorized by Dayton in writing, Dayton will not accept any charges for correcting defects or accept the return of any Product. This warranty will not apply to any Products that have been subjected to misuse, neglect, storage damage, misapplication, accident or any other damage caused by any person other than Dayton, or that have not been maintained in accordance with Dayton's specifications. THIS LIMITED WARRANTY IS IN LIEU OF ALL OTHER WARRANTIES AS TO THE PRODUCTS AND ANCILLARY SERVICES. DAYTON MAKES NO OTHER WARRANTIES OR GUARANTEES, EXPRESS OR IMPLIED, INCLUDING ANY WARRANTY OF MERCHANTABILITY, FITNESS FOR A PARTICULAR PURPOSE OR OTHERWISE. THE REMEDIES SET FORTH IN THIS SECTION ARE CUSTOMER'S EXCLUSIVE REMEDY FOR BREACH OF WARRANTY.