

TECHNICAL DATA SHEET

DESCRIPTION

Dayton Superior B33 Double Flared Criss Cross Coil Loop Insert consists of two flared wire loops welded to a helix coil.

PRODUCT SPECIFICATION

- Available in 1", 1-1/4" and 1-1/2" diameters
- Used in conjunction with the D40 He-Bolt for form anchorage

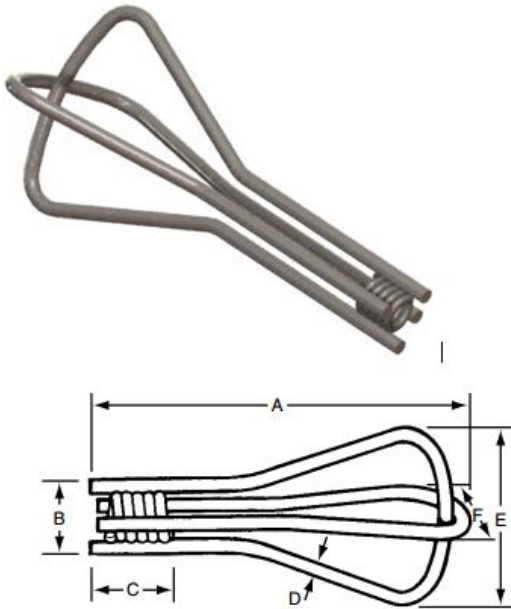

FEATURES

- Ability to use the flange and nails to attach the system to formwork
- Components can be fabricated to order with straight, bent, hooked, or double ended

BENEFITS

- Minimum spacing between inserts is twice the minimum corner distance.
- Crisscross design will not allow the insert to "straddle" reinforcing steel or prestressing strands.

TECHNICAL DATA

Bolt Diameter	Minimum Edge Distance	Minimum Corner Distance	Safe Working Load Tensions (lbs)	Safe Working Load Shear (lbs)	Dimensions			
					A	D	E	F
1", 1-1/4", or 1-1/2"	5"	15"	9,820	5,520	12-3/8"	0.375"	5-9/16"	5-9/16"
	9"	15"	19,000	13,440				
	12"	18"	19,000	19,000				
	18"	18"	19,000	19,000				
1", 1-1/4", or 1-1/2"	5"	15"	9,940	5,880	12-1/2"	0.440"	5-3/4"	5-3/4"
	9"	15"	19,300	14,240				
	12"	18"	21,920	21,920				
	22"	22"	27,000	27,000				

Safe working loads provides a factor of safety of 2:1 in 3,000 psi normal weight concrete
 Loads are based on 1/2" setback from face of concrete

RELATED PRODUCTS

- B12 - Coil Rod
- B14Coil Bolt
- F48 - Eye Nut
- F49 & F49A - Eye Bolt
- D40 He-Bolt for form anchorage

ORDERING INFORMATION

DOUBLE FLARED CRISS CROSS COIL LOOP INSERT

Product Code	Description	Weight
44900	1" X 12-3/8"	2.37 LB
44910	1" X 12-1/2"	3.12 LB

MANUFACTURER

Dayton Superior Corporation
 1125 Byers Road
 Miamisburg, OH 45342
 Customer Service: 888-977-9600
 Technical Services: 877-266-7732
 Website: www.daytonsuperior.com

WARRANTY (ACCESSORIES)

Limited Warranty. Dayton warrants, for a period of 60 days from the date of shipment (three years from the date of shipment in the case of formwork, excluding any consumable Products included with such formwork), that Products and any associated application drawings and engineering services provided by Dayton ("Ancillary Services") will be free from defects in material and workmanship and, in the case of custom designed formwork, that the formwork will meet the specifications set forth in the design drawings approved by Dayton and Customer. Any claim under this warranty must be made in writing within such warranty period. If any Product and/or Ancillary Service covered by a timely claim are found to be defective, Dayton will, within a reasonable time, make any necessary repairs or corrections or, at Dayton's option, replace the Product. Unless pre-authorized by Dayton in writing, Dayton will not accept any charges for correcting defects or accept the return of any Product. This warranty will not apply to any Products that have been subjected to misuse, neglect, storage damage, misapplication, accident or any other damage caused by any person other than Dayton, or that have not been maintained in accordance with Dayton's specifications. THIS LIMITED WARRANTY IS IN LIEU OF ALL OTHER WARRANTIES AS TO THE PRODUCTS AND ANCILLARY SERVICES. DAYTON MAKES NO OTHER WARRANTIES OR GUARANTEES, EXPRESS OR IMPLIED, INCLUDING ANY WARRANTY OF MERCHANTABILITY, FITNESS FOR A PARTICULAR PURPOSE OR OTHERWISE. THE REMEDIES SET FORTH IN THIS SECTION ARE CUSTOMER'S EXCLUSIVE REMEDY FOR BREACH OF WARRANTY.