

TECHNICAL DATA SHEET

DESCRIPTION

The D487 Seal Plug is a rubber plug to seal connections between grout sleeves and the associated reinforcing bar. It is designed to keep concrete from entering the inner cavity of the grout sleeve.

APPLICATION

D487 Field End Seal Plug Application:

Used with either the D390 or the D410 Dayton Superior® Grout Sleeves and is designed specifically for use on the field end of the associated grout sleeve. This seal plug is designed to keep concrete & debris from entering the inner cavity of the DSC Grout Sleeve. (Typically seen in the removal of pour strips in tilt applications)

D487 Sleeve-Lock® Seal Plug Application:

Used only with the D410 Grout Sleeve and is used on the factory end of the sleeve. This seal plug works to keep concrete out of the inner cavity while a panel is being casted. It works as a barrier between concrete and grout from within the cavity. (Used in both precast applications and the removal of pour strips in tilt applications)

RELATED PRODUCTS

- D390 Taper-Lock® Grout Sleeve
- D410 Sleeve-Lock® Grout Sleeve

HOW TO ORDER

- Specify: (1) quantity, (2) name, (3) part number
Example: 80, D487 Field End Seal Plug, PCN 102402

ORDERING INFORMATION

GROUT SLEEVE PLUGS - D487 FIELD END SEAL PLUG

Product Code	Description	Weight
102400	FITS #4 [13MM] - D390 & #4 TO #5 [13MM-16MM] - D410	0.043 LB
102401	FITS #5 [16MM] - D390	0.050 LB
102402	FITS #6 [19MM] - D390 & #6 TO #7 [19MM-22MM] - D410	0.066 LB
102403	FITS #7 [22MM] - D390	0.074 LB
102404	FITS #8 [25MM] - D390 & #8 TO #9 [25MM-29MM] - D410	0.080 LB
102405	FITS #9 [29MM] - D390 & #10 [32MM] - D410	0.088 LB
102406	FITS #10 [32MM] - D390 & #11 [36MM] - D410	0.103 LB
102407	FITS #11 [36MM] - D390	0.128 LB
102408	FITS #14 [43MM] - D410	0.140 LB
102409	FITS #14 [43MM] - D390	0.160 LB
102410	FITS #18 [57MM] - D410	0.169 LB
102411	FITS #18 [57MM] - D390	0.199 LB

GROUT SLEEVE PLUGS - D487 SLEEVE-LOCK® SEAL PLUG

Product Code	Description	Weight
139630	FITS #4 TO #5 [13MM-16MM] - D410	0.039 LB
139631	FITS #6 TO #7 [19MM-22MM] - D410	0.061 LB
139632	FITS #8 TO #9 [25MM-29MM] - D410	0.070 LB
139633	FITS #10 [32MM] - D410	0.071 LB
139634	FITS #11 [36MM] - D410	0.078 LB
139635	FITS #14 [43MM] - D410	0.086 LB
139636	FITS #18 [57MM] - D410	0.124 LB

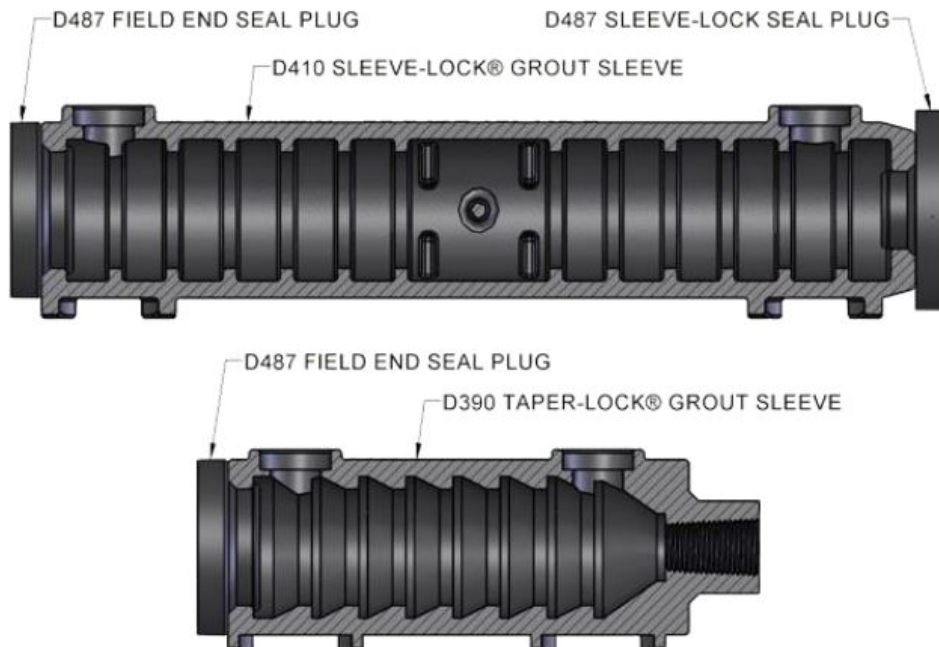

TECHNICAL DATA SHEET

MANUFACTURER

Dayton Superior Corporation
1125 Byers Road
Miamisburg, OH 45342
Customer Service: 888-977-9600
Technical Services: 877-266-7732
Website: www.daytonsuperior.com

WARRANTY (ACCESSORIES)

Limited Warranty. Dayton warrants, for a period of 60 days from the date of shipment (three years from the date of shipment in the case of formwork, excluding any consumable Products included with such formwork), that Products and any associated application drawings and engineering services provided by Dayton (“Ancillary Services”) will be free from defects in material and workmanship and, in the case of custom designed formwork, that the formwork will meet the specifications set forth in the design drawings approved by Dayton and Customer. Any claim under this warranty must be made in writing within such warranty period. If any Product and/or Ancillary Service covered by a timely claim are found to be defective, Dayton will, within a reasonable time, make any necessary repairs or corrections or, at Dayton’s option, replace the Product. Unless pre-authorized by Dayton in writing, Dayton will not accept any charges for correcting defects or accept the return of any Product. This warranty will not apply to any Products that have been subjected to misuse, neglect, storage damage, misapplication, accident or any other damage caused by any person other than Dayton, or that have not been maintained in accordance with Dayton’s specifications. THIS LIMITED WARRANTY IS IN LIEU OF ALL OTHER WARRANTIES AS TO THE PRODUCTS AND ANCILLARY SERVICES. DAYTON MAKES NO OTHER WARRANTIES OR GUARANTEES, EXPRESS OR IMPLIED, INCLUDING ANY WARRANTY OF MERCHANTABILITY, FITNESS FOR A PARTICULAR PURPOSE OR OTHERWISE. THE REMEDIES SET FORTH IN THIS SECTION ARE CUSTOMER’S EXCLUSIVE REMEDY FOR BREACH OF WARRANTY.