



BUILDING STRENGTH™

TILT-UP HANDBOOK

**CONCRETE
CONSTRUCTION
PRODUCTS**





General and Technical Information 1

- Tilt-Up Construction 1
- Early History of Tilt-Up 1
- Dayton Superior’s Role in the Development of Tilt-Up 2
- Technical Assistance 2
- General Tilt-Up Considerations 2
- Definitions 2
- Safety Notes and Product Application 3
- Safety Factors 3
- Lifting Stresses and Concrete Design 4
- Safe Working Load Reduction Factors for Lightweight Concrete... 4
- Anchor/Insert Capacity 5
- Edge and Shear Loading 6
- Anchor/Insert Failure 6
- Coil Bolt/Coil Insert Failure 6
- Insert Placement 7
- Insert Edge Distances 8
- Loading Conditions 8
- Tilt-Up Problem Areas 9
- Tilt-Up Construction Considerations 10
- Panel Casting Layout 11
- Panel Construction 11
- Preparation for Lifting 11
- Panel Preparation 11
- Panel Analysis 12
- During the Lift - Precautions 12
- Plumbing Panels - Precautions 13
- Bracing - General 13
- Erection Details 13
- Computer-Aided Design Software 14

Panel Erection Information 16

- Standard Rigging Details 16
- Boom Positioning 17
- Plumbing Face-Lifted Panels 17
- Brace and Re-Rig Method 18
- Transfer Method 18

Lifting Systems 19

- Superior Lifting System 19
- Ground Release Lifting System 19
- Gyro Tilt Plus System 19
- Coil Lifting System 19
- T110 Superior Lift System 20
- P99P Fleet Patch 21
- T275 Tilt-Up Anchor 21
- T275B Base Plates 22
- T275P Patch Cap 22
- T120 Superior Lift Hardware 23
- Exposed Aggregate Panel Inserts 23
- How to Remove the T110 Plastic Recess Plug 24
- Proper Hardware Usage 24
- T120 Superior Lift Hardware Installation Sequence 25
- T120 Superior Lift Lifting Hardware Release Sequence 25
- T110E Edge Lift Application 26
- P98T Fleet-Lift Tension Bar 26

Ground Release^{II} System 27

- T41 Ground Release^{II} Insert 27
- T43L Ground Release^{II} Lifting Hardware 28
- How to use the Ground Release^{II} System — T43L Hardware 28
- How to Remove the T41 Ground Release^{II} Plastic Recess Plug 29
- Proper Hardware Usage 29

- T42 Double Ground Release^{II} System 30
- T46HD Ground Release^{II} Spreader Beam with Twin Shackles 30
- T45 Ground Release^{II} Patch Cap 30
- T81 Heavy Duty Ground Release^{II} Insert 31
- T83 Heavy Duty Ground Release^{II} Hardware 31
- How to use the Ground Release^{II} System — T83 Hardware 32
- P52 Swift Lift[®] Anchor 33
- P54 Swift Lift[®] Recess Plug 33
- P59 Swift Lift[®] Shear Bar 33
- P52 Swift Lift Anchor Tension SWLs 34
- Swift Lift[®] Anchor Shear (Edge Lifting) SWLs 35
- Suggested Rigging Method 35
- How To Install the Swift Lift Anchor 36
- P53 Swift Lift[®] Eye Anchor - Edge Lifting 37
- P53 Swift Lift Eye Anchor for Lifting and Handling 37
- P53 Swift Lift Eye Anchor Selection Chart 37
- P60 Swift Lift[®] Tension Bar 38
- P60 Swift Lift Tension Bar Installation 38
- P51SL Lifting Eye — Edge Lifting in Shear Condition 39
- How to Use the P51SL Lifting Eye: 39

Gyro Tilt[™] Plus System 41

- Gyro Tilt Plus[™] System* 41
- Gyro Tilt Plus Face Lift Insert 41
- T49E Gyro Tilt Plus Edge Lift Insert 42
- T50 Gyro Tilt Plus Hardware 43
- T51 Gyro Tilt Plus Shear Bar 43
- T52 Heavy Duty Gyro Tilt Plus Insert 43
- T53 Heavy Duty Gyro Tilt Plus Hardware 43
- How to use the Gyro Tilt Plus System 44
- How to Remove the Gyro Tilt Plus Plastic Recess Plug 45
- Proper Hardware Usage 45

Coil Inserts 47

- T1 Single Pick-Up Insert 47
- T21 Insert Locator Plugs 47
- T2 Double Pick-Up Insert 48
- T7S, T7ST Slotted Setting Plugs 48
- Exposed Aggregate Details 49
- How to use Coil Face Inserts 50
- Edge Pick-up 51
- Proper Placement of “Edge” T3 or T3A Inserts 51
- Total System and Safe Working Loads 52
- Coils 52
- How to Determine Bolt Length 52
- B14 Coil Bolts and Minimum Coil Penetration Information 53
- T8 Lifting Angle 54
- T12 Swivel Lift Plate 54
- T26 Double Swivel Lifting Plate 54
- T27 Edge Lifting Plate 54
- Continuous Coil Threaded Rod 55
- B13 Coil Nut and B25 Heavy Nut 55
- B11 Flat Washer 55

Strongback System 57

- Strongbacks 57
- Strongback-Shore/Blocking 57
- Strongbacks Using Coil Inserts, Coil Bolts and Flat Washers 58
- T63 Aluminum Strongback Beams 59
- T63S Splice Plate for T63 Beams 59
- Strongback Assemblies 59

General and Technical Information

Panel Erection Information

Lifting Systems

Ground Release^{II} System

Gyro Tilt[™] Plus System

Coil Inserts

Strongback System

Bracing Information

Sandwich Panel Connectors

Panel Connectors

Sleeve-Lock® Grout Sleeve

Formliners Architectural Concrete

Miscellaneous and Chemical Products

Bracing Information 61

Brace Wind Loading..... 61

Brace Removal 62

Brace to Floor Slabs..... 63

Brace Length and Safe Working Loads 63

T14 Tilt-Up Wall Braces..... 64

T15 Pipe Brace Extensions..... 64

Brace Length and Ultimate Loads..... 65

Corner Bracing..... 66

Brace Maintenance..... 66

Accubrace® Total Bracing System 67

Accubrace Components Overview..... 68

Helical Ground Anchors and HGA Extensions 68

Transition Brace Connectors and Braces..... 68

Bearcat™ Bolt Multi-Use and Single-Use..... 70

T13 Coil-Anchor™ 3/4" Diameter x 4-1/2" Long Application Sequence..... 72

T13G Thread Gauge..... 72

T13L Set-Eez™ Dry Film Lubricant..... 72

T13 Coil-Anchor™ 3/4" Diameter x 6" Long Application Sequence 73

T13G Thread Gauge..... 73

T4 Brace Anchor for Fill 73

T5A Inverted Wall Brace Anchor 74

T5A Stick On Foam Dot Indicator 74

T6A-Heavy Brace Anchor 75

Cast-In-Place Brace Anchor Loading..... 75

T28 Superior Plate Dowel..... 75

Sandwich Panel Connectors 76

P24 Delta Tie..... 76

P24 Delta Tie Design Chart..... 77

Typical Delta Tie Placement 77

Composite Moment Capacity..... 77

P24XL Delta Tie..... 78

Delta Tie Installation Information 78

P27 Yeti-Anchor..... 79

P12G Welded Wire Griders 80

P9 Sandwich Panel Tie..... 81

P37 "M" Anchor Shear Connector 81

Panel Connectors 82

P30 Corewall® Nut Type Slotted Insert 82

P31 Corewall® Strap Type Slotted Insert..... 82

P30 Corewall® Nut Type Slotted Insert..... 82

P31 Corewall® Strap Type Slotted Insert..... 83

P32 Corewall® Strap Anchor 83

P33 Corewall® Slotted Strap Anchor 83

P34 Corewall® Threaded Strap Anchor..... 83

P38 Corewall® Slotted Insert II..... 84

Corewall® Edge and Corner Details..... 85

Sleeve-Lock® Grout Sleeve..... 87

D410 Sleeve-Lock® Grout Sleeve..... 87

Sleeve Lock® Components 88

D490 Sleeve-Lock® Grout..... 88

D487 Sleeve-Lock® Seal Plug 88

D491 Sleeve-Lock® Form Plug 88

D492 Sleeve-Lock® 3/4" SCH40 PVC..... 88

D493 Sleeve-Lock® Port Plug..... 88

Formliners 89

Thermoform™ Vacuum-Formed Formliners 89

Fractured Patterns..... 90

Wood Patterns..... 91

Smooth Flute Patterns..... 92

Block Patterns..... 93

Brick Patterns..... 93

Stone Patterns..... 94

Other Patterns..... 95

Application Guide 95

Miscellaneous 96

T58 Double Chamfer Strip 96

T59 Plastic Keyway 96

T66 Tilt Bracket™..... 96

T29 Superior Panel Base Anchor 10K (PBA 10K)..... 96

T29 PBA 10K Shear Connector..... 97

T68 ACA-1000 Construction Spray Adhesive..... 97

GluDown..... 97

T69 T Strip..... 97

T70 EZ Nail Form Bracket..... 97

Rustications, Chamfers and Other Products 98

T75 and T75HD Special Drill-in Lift Plate..... 99

P80 Shim Strips 100

P81 Superior Shimpak 100

Loop End Wire Ties - WBT..... 100

Aztec® E-Z Chair™ PEZ 101

Aztec® E-Z Connect™ PSB..... 101

Aztec® Strongback SBU (Slab Bolster Upper) PSBU..... 101

Paragon Mesh Chair 101

Aztec® Castle Chair™..... 101

Paragon Test Cylinders 102

Paragon Hole Covers..... 102

Kodi Klip® K-Klips..... 102

A95 Dayton Bar 103

Bar Chair - BC..... 104

Individual High Chair - HC 104

Slab Booster - SB..... 104

Slab Booster Upper - SBU 104

Continuous High Chair - CHC 104

Premium Tie Wire - WTW 104

G33 Screed Key Joint 105

G34 Load Key Joint 105

G37 Stake..... 105

G38 Plastic Cap Strip 105

Material..... 105

Cures and Bondbreakers for Tilt-Up..... 106

Preparation for Applying Bondbreaker..... 106

Placement of Bondbreaker 106

"Good Indications" 106

Solvent-Based vs Water-Based..... 106

Bondbreakers..... 107

Cure & Seal Compounds 107

Densifiers & Sealers..... 107

Evaporation Reducers 108

Epoxy Joint Fil for Saw Cuts..... 108

Latex Bonding Agents / Admixtures..... 108

Non-Shrink Grout..... 108

Panel Smoothing / Prep and Spray Adhesive 108

Panel Checklist 109

Index..... 110

Tilt-Up Construction

Tilt-up is a job-site form of precast concrete construction. It involves prefabricating concrete wall sections (panels) flat on either the building floor slab or on a temporary casting slab, then lifting or tilting them up and carrying them to their final position with a mobile crane. Once they are in position, the panels are temporarily braced until they are tied into the roof and floor system and become an integral part of the completed structure.

It is a fast, simple, and economical method of construction, which has been used extensively for single and multi-story structures. Today, walls of up to four stories in height are being cast and tilted into position. Currently, there have been several instances of wall panels as high as six stories being cast and erected by the tilt-up method of construction.

The economic benefits of tilt-up lie in its simplicity of construction. The critical factors in this method of construction are handled in the pre-construction planning stage. Skill in laying out panel erection sequences and designing safe lifting elements which fully utilize crane time will provide for the effective and safe completion of the job.

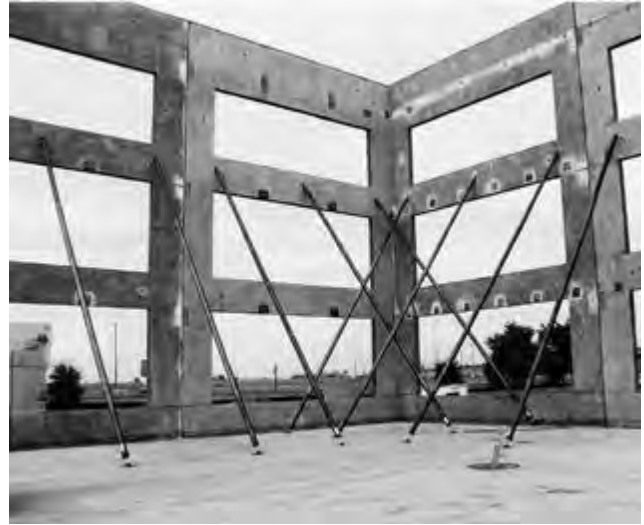

Early History of Tilt-Up

Robert Hunter Aiken erected the earliest known tilt-up building around 1893, at Camp Logan, Illinois located just north of the town of Zion. As mobile cranes were not available during this time-period, Mr. Aiken used a specially designed tipping table on which to cast and erect the wall panels.

Mr. Aiken is recognized by many as being the father of what is now known as tilt-up construction. In addition, Mr. Aiken developed the first insulated tilt-up wall panels, which consisted of 2" of concrete, 2" of sand and 2" of concrete. As the panels were tipped into position, workers washed the sand from between the concrete wythes, leaving an insulating center air space.

In an article published around 1910, Mr. Aiken reported that two men were able to erect a wall, in one hour, that was 76 feet long by 27 feet tall and weighed 76 tons. In this same article, Mr. Aiken stated he had used his tipping table method of construction to erect fifteen structures in five different states. His method of construction was known as the "Aiken method of house building."

Only two mid-western buildings constructed using Mr. Aiken's "method of house building" are known to survive. They are the Memorial United Methodist Church of Zion, IL and the Camp Perry Commissary Building 2009 located near Port Clinton, Ohio. The Zion church was erected in 1906 and the Commissary in 1908. Both buildings stand today as monument to the longevity of tilt-up construction.

In 1911, Robert Aiken and his Aiken Reinforced Concrete Company, Inc. used his innovative construction method to erect 111-foot x 644-foot Paint Shop building, containing 36 rail car bays, for the Los Angeles Railway Company. The building's 106-foot long, 100-ton wall sections were cast horizontally and then tipped into position. This building is undoubtedly the largest of its era to employ tilt-up construction.

Also in Los Angeles, Mr. Thomas Fellows, developed a variation of the Aiken system in 1910 and used it to construct a low-cost demonstration house. Mr. Fellows cast the modular wall units horizontally on the ground and later lifted them into place using a mechanical crane.

In 1912, a San Diego based architect, Mr. Irving Gill used the Aiken tipping wall technology in the Banning House in Los Angeles and in the large La Jolla Women's Club building of 1913. In 1912, Mr. Gill purchased the patent rights of the bankrupt Aiken Reinforced Concrete Company and formed his own Concrete Building and Investment Company. However, the Aiken method was determined not to be very useful in concrete construction and Gill did not employ it much after 1913.

Although Mr. Aiken, Mr. Fellows and Mr. Gill pioneered tilt-up construction, modern day tilt-up's popularity is based on two WW II era developments, the introduction of the ready-mix concrete batch plant and mobile cranes.



Dayton Superior's Role in the Development of Tilt-Up

Since the beginning of tilt-up construction, Dayton Superior has been instrumental in developing and manufacturing the hardware necessary for safety and economy in the most critical steps for this method of construction — that of lifting the wall panel and placing it in place without damage. The embedded coil insert pioneered by Dayton Superior was an important development in tilt-up techniques. A major breakthrough resulted in the mid-sixties with the design of the Twist-Lift insert and lifting hardware. The Twist-Lift System was one of the simplest and most economical lifting systems on the market for many years. The Twist-Lift System was a quick connect-release system and was the forerunner of today's ground release systems.

Further innovations have been made through research and development of the Ground Release Swift Lift System for tilt-up construction. This system offers tilt-up contractors the advantage of being able to release of the lifting hardware from the ground with a simple pull on a release line. Worker safety was greatly improved as the Ground Release Swift Lift System eliminated the need for workers to climb a ladder to remove the lifting hardware from the panel.

Dayton Superior has continued to strive to provide the contractor with a variety of options for lifting panels, developing the Gyro Tilt Plus System, the Tilt-Up 3 Lifting System and recently introduced the Superior Lift Tilt-Up System. Our product development team continues to strive to provide a complete package for economical and safe construction of tilt-up buildings.

Technical Assistance

The Dayton Superior Technical Assistance is based on many years of experience involved in detailing several million panels of all shapes, sizes and degree of difficulty. Using computer aided design, the following services are available to serve the needs of the Tilt-Up Construction Industry. Services include:

- Consultation/recommendations
- Panel erection details
- Wind bracing requirements
- Additional reinforcement, if necessary
- Strongback requirements, if necessary
- Rigging methods
- Material takeoffs

General Tilt-Up Considerations

Tilt-up construction involves the following considerations:

- The tilt-up concrete panel is partially supported by the ground or slab during tilting.
- The concrete panel is usually handled only once.
- Tilt-up panel is typically cast close to its erected location.

At the time of initial lift, the face lift inserts and bolts/hardware are in tension or in a combination of tension and shear. As the panel is rotated and raised, tension decreases and shear increases as the entire load is transferred to the inserts (when the panel is in a vertical position).

Tilt-up panels must be reinforced with no less than the minimum steel required by the latest edition of the American Concrete Institute, Building Code Requirements for Reinforced Concrete (ACI 318). If flexural stress limits will be exceeded during lifting, additional reinforcing steel, or strongbacks must be added to the panel.

Definitions

Rated Load	The maximum load that should be applied to an anchor, insert, coil bolt, brace or lifting hardware unit. Safe Working Load, Safe Load Carrying Capacity or SWL are other terms used in this handbook for the term Rated Load.
Ultimate Load	The force at which the item fails or no longer will support or carry a load.
Dynamic Load	A resulting load from the rapid change of movement, such as the sudden stopping, jerking or impacting a static load. A dynamic load may be several times a static load.
Safety Factor	A term denoting theoretical reserve capability which has been determined by dividing the product's ultimate load by its rated load. This is expressed as a ratio; for example, 2 to 1.

Safety Notes and Product Application

Dayton Superior publishes either the Safe Working Load or the Ultimate Load of its products. The Safe Working Loads published are based upon a minimum factor of safety applied the product's ultimate tested load. Therefore, Dayton Superior strongly advises that the minimum safety factors displayed not be exceeded. When there are unusual job conditions, minimum safety factors must be increased to accommodate unusual conditions. Refer to the provisions in the current editions of American National Standards Institute (ANSI A 10.9), Occupational Safety and Health Administration (29 CFR 1926 OSHA), the American Concrete Institute (ACI) *Tilt-Up Concrete Structures (ACI 551)* and *Recommended Practice for Concrete Formwork (ACI 347)* and the *Tilt-up Concrete Association's Guideline for Temporary Wind Bracing of Tilt-Up Concrete During Construction*, when considering safety factors and construction practices.

Warning: Dayton Superior strives to ensure that all products it supplies meet or exceed all safety requirements. However, the performance of a product may be affected by the manner in which the product is used. It is imperative that the user be familiar with the proper installation and use of the products displayed in this publication prior to job application. Failure to properly install and use the products displayed in this publication may lead to serious accidents and/or deaths.

Safety Notes and Product Application:

All safe working loads shown in this publication were established with the following factors considered:

1. All products are in new or "as new" condition. The safe working load is considered the greatest load that should be applied to a product.
2. Inserts are correctly embedded in sound concrete and are firmly bolted or wired in place so that the vertical axis of the inserts is perpendicular to the lifting surface.
3. Concrete compressive strength (f'c) at time of initial lift is at least the strength listed in the insert selection chart for the insert being used.
4. Bolted hardware has full bearing on the concrete surface, and attachment bolts bear fully on the hardware.
5. Caution must be taken so that the hardware is not subjected to a side loading that will cause an additional, unintended loading.
6. Erection and attachment bolts are the proper length and are well tightened to prevent hardware slippage and bolt bending.
7. Coil bolts have minimum coil penetration through the insert coil, but are not bearing on concrete at the bottom of the void.
8. Inserts are properly located in relation to edges, corners and openings, and are at distances that permit the development of a full shear cone. Minimum edge distances are noted throughout this publication.
9. The applied load on an insert is calculated to include the effect of both axial and transverse loads.
10. Electroplated inserts have been properly baked to relieve brittleness. Failure to do so may result in premature failure.
11. No field welding to the lifting inserts or lifting hardware has taken place. Welding may result in premature failure. Since Dayton Superior cannot control field conditions or field workmanship, Dayton Superior does not guarantee any product altered in any way.

Dayton Superior offers several lifting systems, each designed and tested for use as part of an overall system. More specifically, Dayton Superior's lifting hardware has only been tested, and thus approved for use, with Dayton Superior inserts and anchors.

Dayton Superior DOES NOT recommend and cannot provide support for the use of our lifting hardware, inserts and anchors with any product other than those manufactured by Dayton Superior.

If any lifting hardware, inserts and/or anchors of any other brand are used in any combination with Dayton Superior's lifting hardware, inserts and/or anchors, it will be defined as a misuse of our product. As such, Dayton Superior cannot be held liable for any damages or injuries resulting from misuse of our products.

Safety Factors

Dayton Superior recommends the following minimum safety factors identified by Occupational Safety and Health Administration (29 CFR 1926 OSHA), the American National Standards Institute (ANSI 10.9), and the Tilt-up Concrete Association's Guideline for Temporary Wind Bracing of Tilt-up Concrete During Construction.. Tilt-up construction may require additional safety considerations. Many field conditions may warrant higher safety factors, i.e., adhesion of the panel to the casting surface, jerking the crane during lift, inadequate crane size, improper handling of an erected panel, transporting an erected panel over rough surfaces, exceeding boom capacity, etc. The minimum safety factors listed below should be adjusted accordingly when any of the above conditions are known to exist. If a different safety factor is required for any reason, the published safe working load must be adjusted. The following equation is used to adjust a safe working load:

Safety Factor	Intended Use of Product
1.67 to 1	Tilt-Up Wall Braces
2 to 1	Floor and Wall Brace Anchors
2 to 1	Lifting Inserts
3 to 1	Permanent panel Connections
4 to 1	Handling Panels Multiple Times
5 to 1	Lifting Hardware and/or Reusable Hardware

$$\text{New Safe Working Load} = \frac{\text{Old Safe Working Load} \times \text{Old Safety Factor}}{\text{New Safety Factor}}$$

Warning: New Safe Working Load must not exceed the product's Mechanical Capacity — New Safety Factor. Contact Dayton Superior Technical Assistance for determining product mechanical capacity.

Lifting Stresses and Concrete Design

Lifting and rotating a wall panel creates high stresses that may exceed in-place construction values. A tilt-up wall panel with low concrete compressive strength is more susceptible to failure by erection stresses.

The maximum erection stress occurs as the horizontal panel is tilted into a vertical position. These applied stresses happen early in the construction sequence, before the concrete has attained full strength. Properly applied Bond Breaker is important to allow for reducing these applied stresses.

As the panel is tilted, the dead weight of the panel induces a flexural moment with associated stresses. The stress level is dependent on the size and weight of the panel, the number of openings, the number of lifting inserts and locations, and the type of rigging and cable lengths used. The stresses incurred during lifting can be accounted for and resisted in most cases by means of; proper insert design and placement, strongback options, various reinforcing techniques and/or by increasing the compressive strength of the concrete at the time of lift.

Concrete is weak in tension, therefore induced tensile stresses are limited to values below the tensile resistance of the concrete. The table below lists various safe tensile stress limits.

Concrete Weight	Allowable Tensile Stress
150 PCF	$6\sqrt{f'_c}$
Greater than 110 PCF and less than 150 PCF	$0.85 \times 6\sqrt{f'_c}$
110 PCF	$0.75 \times 6\sqrt{f'_c}$

Note: f'_c refers to the actual concrete compressive strength at time of lift.

Safe Working Load Reduction Factors for Lightweight Concrete

Safe working loads for the products shown in this publication were derived from analysis and testing using reinforced normal weight concrete (150 pcf). The safe working load of an insert is dependent on the compressive strength and density of the concrete in which it is embedded. Therefore, when Dayton Superior tilt-up inserts are used in "lightweight" concrete tilt-up panels, the safe working load must be recalculated to compensate for the reduction in concrete density. Multiply the published safe working load by the reduction factor shown in the table to obtain the corrected safe working load.

Concrete Type	SWL Reduction Factor
Normal Weight	1.0
Sand-lightweight Concrete	0.85
All-lightweight concrete	0.75
For all-lightweight concrete with a weight of 110 pcf or less	Verify by testing

Interested readers are referred to section 19.2 of the American Concrete Institute's "Building Code Requirements for Reinforced Concrete (ACI 318)" for additional information.

Anchor/Insert Capacity

Anchors/Inserts are designed to resist loads applied as direct tension, shear or a combination of the two. The following equations have been developed to predict concrete capacity of anchors/inserts and are applicable to anchors/inserts that are properly embedded in unconfined concrete. Confinement of the concrete, either from an applied compressive force or reinforcement is known to increase the load carrying capacity of concrete. At this time, design equations for anchors/inserts, which include reinforcement confinement, have not been developed.

The Strength of the Concrete

When a load is applied to an insert embedded in concrete, it induces a corresponding resistive force in the concrete. Insert failures can be predicted with a reasonable degree of accuracy by using the following equation for concrete breakout from ACI 318 Chapter 17.

f'_c = Compressive strength of the concrete at time of lift

$$P_{\text{concrete}} = 0.75 \times j_{c,N} \times l \times 24 \times \sqrt{f'_c} \times h_{ef}^{1.5}$$

P_{concrete} = Maximum tension load carried by concrete and;

l = Reduction factor for use with lightweight concrete, see next page;

$j_{c,N}$ = Factor for cracked concrete: 1.0 if cracked and 1.25 if uncracked.

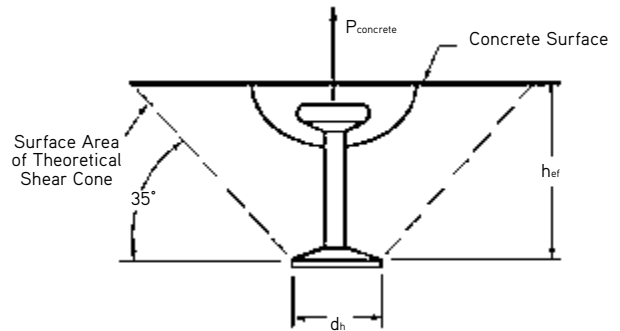

Illustration A2

Combined Shear and Tension Interaction

Anchors/inserts and bolts that are subjected to combined shear and tension loading should satisfy the following equation:

Where:

f_v = applied shear load

F_v = shear safe working load

$$\left(\frac{f_v}{F_v}\right)^{5/3} + \left(\frac{f_t}{F_t}\right)^{5/3} \leq 1.0$$

f_t = applied tension load

F_t = tension safe working load

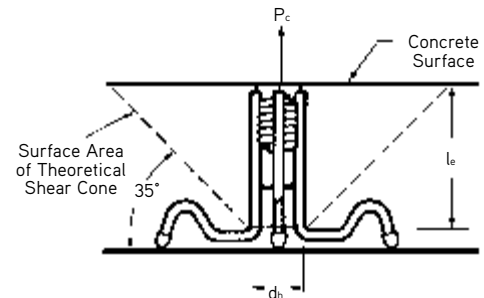

Note: Dayton Superior considers the interaction between tension and shear of the anchor/insert when developing lifting and bracing designs. These calculations should be done by a qualified person

Edge and Shear Loading

Another condition encountered is an insert embedded near a free edge or corner and loaded in a direction transverse to the axis of the bolt, toward the free edge. Edge lift panels are examples of this condition.

Tests have shown that edge inserts loaded transversely to destruction (see Illustration L) fail because of an initial failure of the concrete over the coil. This initial failure transfers the entire load to the insert struts. If the load is large enough, the struts will fail in bending or shear or both.

An analysis of the tests indicates that the ultimate load on edge inserts loaded in the direction of the free edge is a function of the distance from the insert to the free edge. The effect of bolt diameter and insert configuration appears to be of secondary and negligible importance. For conditions where shear loading must be considered, it is appropriate to use the following equation from ACI 318 Chapter 17:

$$\text{Shear Safe Working Load (lbs.)} = \frac{\psi_c \cdot \lambda \cdot 7 \left(\frac{l_e}{n \cdot d_o} \right)^{0.2} \cdot \sqrt{n \cdot d_o} \cdot \sqrt{f'_c} \cdot (c_{a1})^{1.5}}{\text{Appropriate Safety Factor}}$$

With the maximum shear safe working load equal to, or less than, the insert's tension Safe Working Load. Where:

- j_c = Cracked concrete factor: 1.0 for cracked concrete and 1.4 if uncracked.
- l = Reduction factor for lightweight concrete, see page 6.
- l_e = Minimum of embedment length or $8 \times (n \times d_o)$.
- n = Number of struts on the insert.
- d_o = Diameter of the insert struts.
- f'_c = Specified concrete compressive strength.
- c_{a1} = Distance from centerline of the insert to the edge.
- For conditions where a corner or thickness in direction of embedment is less than $1.5 \times c_{a1}$ or an adjacent insert is closer than $3 \times c_{a1}$ contact Dayton Superior Technical Assistance for insert capacities.
- For cases where increased shear capacity is required, the addition of pre-formed shear bars over the top of the insert will greatly increase the distribution of the load. Shear bars, when used, must be in solid contact with the insert to be effective.
- If accurate capacities of inserts are desired, several inserts with shear bars should be tested in job size panels.

Anchor/Insert Failure

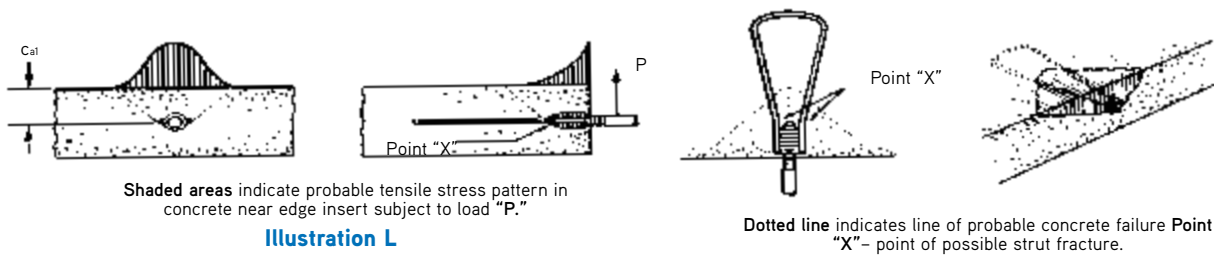

Coil Bolt/Coil Insert Failure



When the applied load P exceeds the pullout capacity of the insert, the insert will fail in one of four ways:

The entire insert may pull out of the concrete, with little apparent damage to the concrete. Such failures are rare and when they do occur, are the result of bond failure between the concrete and insert. These failures usually occur in green, or low strength concrete.

The entire insert may pull out of the concrete bringing with it a cone of concrete having its apex slightly above the most deeply embedded part of the insert. Such failures usually occur when the tensile strength of the shear cone surrounding the insert is not as great as the mechanical strength of the insert itself.

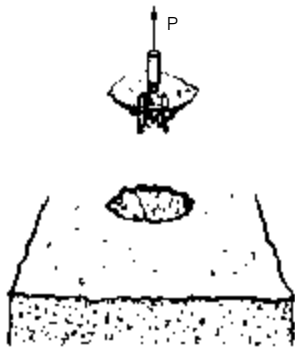

Three

A ductile failure may occur in the insert. Coil type inserts will usually fail at a point just below the helically wound wire coil. A small cone of concrete will usually be pulled out of the concrete surface. This cone will have its apex at a point just below the coil. Its base diameter will be approximately twice its cone height.

“Headed” type inserts will exhibit a ductile failure through the shaft diameter of the insert.

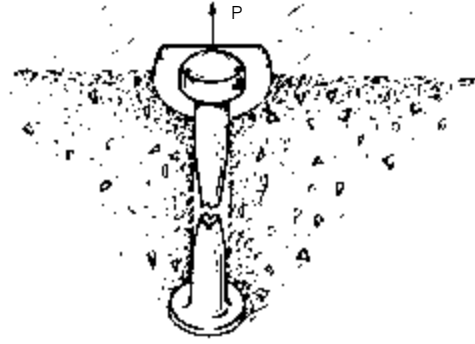

Four

These failures usually occur in higher strength concrete or adequate embedments when the concrete resistance is greater than the mechanical strength.

Failures of this type are due to a definite overload being applied to the inserts. Such failures can be prevented by choosing inserts of capacity suitable to job conditions or by increasing the number of inserts used to lift the tilt-up panel.

Insert Placement

Warning! When bolting coil type inserts, the bolt should always extend at least the proper amount beyond the bottom of the insert coil. Failure to do this causes the entire bolt load to be transferred to fewer turns of the coil, causing an increased load per weld contact point. The coil will then unwind much like a corkscrew, resulting in a premature failure. See “Minimum Insert Distances” in the Superior Lifting Systems section for proper method of determining bolt lengths.

Tilt-up lifting inserts are generally categorized in two types, face lift and edge lift. Both types of inserts must be placed accurately and positioned properly. Capacity of the insert may decrease considerably if the insert is not positioned perpendicular to the bearing surface. All Dayton Superior lifting inserts are designed for easy positioning and securing to the reinforcement steel.

It is also important that all coil style lifting inserts be placed so the depth of thread is constant throughout the job, minimizing improper bolt engagement. Keep all lifting inserts free of debris which may interfere with hardware engagement.

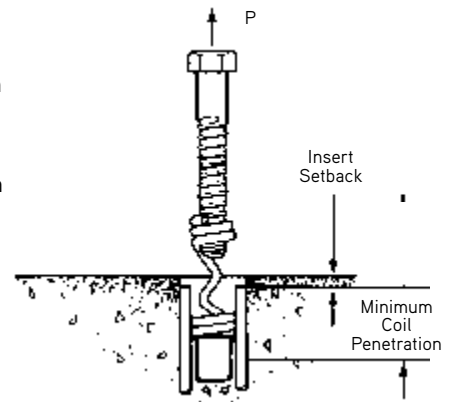

Insert Edge Distances

Embedment of inserts closer to any edge; construction joint; window or door opening than the minimum edge distances shown in this handbook could greatly reduce the effective area of the resisting concrete shear cone and thus reduce the insert's safe working load. The shaded area of the shear cone indicates the extent to which this area is reduced. Safe working loads of inserts near a free edge or corner must therefore be reduced in proportion to the reduction in effective shear cone area.

d_e = Actual edge distance

D = Minimum edge distance required to develop insert's SWL

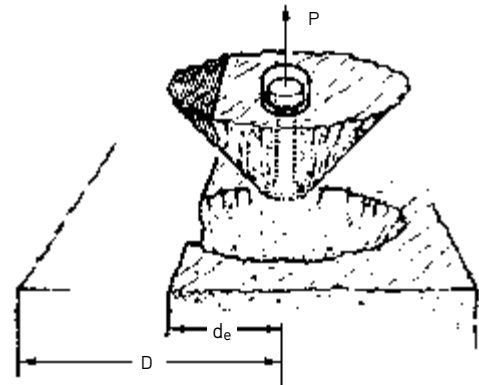

Loading Conditions

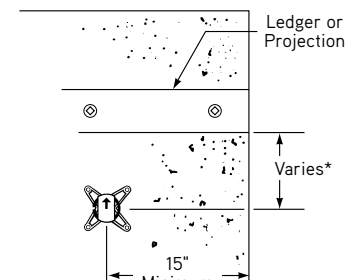
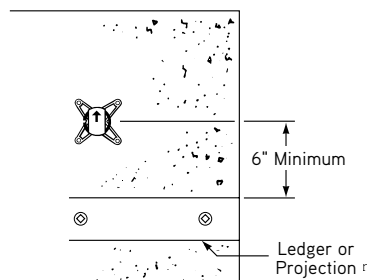
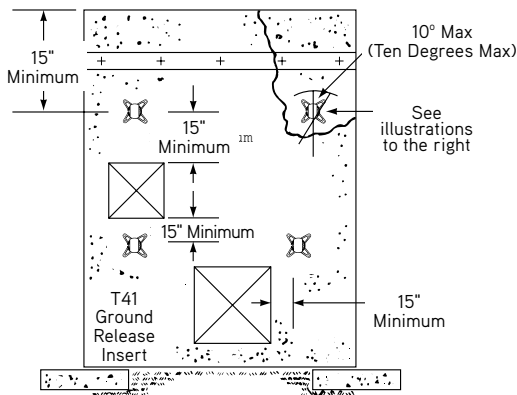

*depending on ledge thickness

Warning! All Lifting Inserts must be properly located in relation to the center of gravity of the panel. (As shown on the Dayton Superior Technical Service panel drawings.)

Safe working loads shown in this publication are for static load conditions and must never be exceeded. If dynamic forces or impact load conditions are anticipated, the safe working loads must be reduced accordingly.

Care must be exercised to ensure that all inserts and hardware are properly aligned, all lifting plates and bolts are properly secured, all rigging is equalized and that proper size crane cables are used. The centerline of the spreader bar and hook must be over the center of gravity of the panel and the crane cables must be of proper size and length.

Warning! Users of Dayton Superior products must evaluate the product application, determine the appropriate safety factor, calculate the applied loads and control all field conditions to prevent excessive product loading.

When uncertain about proper installation or use of a Dayton Superior product, contact Dayton Superior for clarification. Failure to do so may expose workers to hazards which could result in serious injury and/or death.

Tilt-Up Problem Areas

Field Conditions, Equipment and Panel Sizes

Become familiar with field conditions and equipment available for the tilt-up project. Crane capacity should be determined by a certified crane operator following OSHA requirements, the crane manufacturer's specifications, and any other applicable governing codes/provisions.

In addition, for rigging and lifting efficiency, qualified riggers should also be used.

Panel Openings

Position openings in the center of the panel. If this is not possible, maintain a 2'-0" leg of concrete. Less than 2'-0" of concrete may require strongbacks or additional reinforcing.

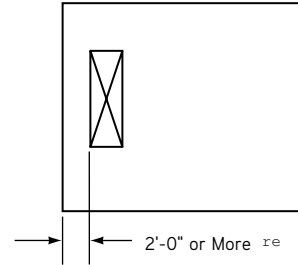

Pier Heights

When pier heights vary, always keep the bottom of the panel parallel to the horizon (see Fig. 1). Avoid panel designs similar to Figures 2 and 3. Designs such as these will require strongbacks, blocking, shoring and/or special handling to prevent panel twisting and spalling.

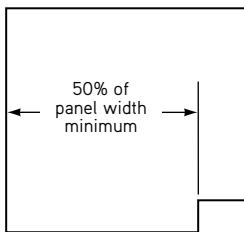

Fig. 1

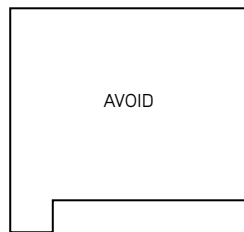

Fig. 2

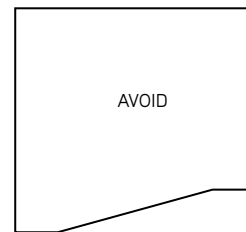
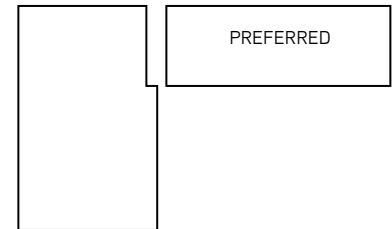
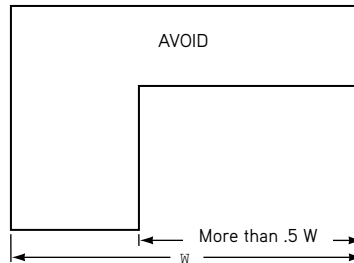

Fig. 3

Headers

Avoid panel designs that have large center of gravity shifts. If a header is required, the example on the right is the preferred design.



Hardware Inspection

All reusable products supplied by Dayton Superior are subject to wear, misuse, corrosion, alteration and other factors which may affect product safe working loads. Dayton Superior recommends that all users of Dayton Superior tilt-up hardware establish a quality control program to monitor and inspect their tilt-up hardware.

The frequency of inspections are best determined by the user and is dependent on the amount of use, duration of use and the environmental conditions during use.

Tilt-Up Construction Considerations

General

The nature of tilt-up construction dictates the need for thorough preplanning. The economy and success of tilt-up construction is realized by efficient on-site production operation and careful planning with each step of the construction sequence building on the previous step. The following sequence is offered as a planning aid for a typical tilt-up project.

Slab as a Work Platform

The quality of the floor slab in a tilt-up constructed building is extremely important. The tilt-up panels are normally cast on the floor slab of the building and any imperfection in the floor slab will be mirrored in the panel. For best results, the floor slab should have a hard, dense, steel trowel surface.

The panel contractor should try to layout the panel forms so that no panels are cast over a floor slab construction or control joint. Should a panel have to be cast over a joint, an effective method for eliminating a control joint image from a panel is to utilize the Dayton Superior T Strip. The T Strip is inserted into the control joint at the time the joint is saw cut. It provides spalling protection for the joint and will leave only a small rounded depression in the tilt-up panel. The small rounded depression is then easily eliminated with a later skim coating of Dayton Superior Sure finish.

The floor area at a column block-out can be made available for casting by filling the block-out with sand to about three inches from the floor surface and then finish filling it with concrete. The block-out image will be transferred to the panel, so choose a panel to cast over the block-out that is not critical to the building's aesthetics.

The floor slab analysis is an integral part of the Tilt-up design and construction process. Please refer to the "Brace Information" section of this handbook for more information.

Bondbreaker and Curing Compounds

Bondbreakers and curing compounds are among the most critical materials used on a tilt-up project. These products should have their performance criteria carefully evaluated. The application of the curing compound on the floor slab is a critical step in the preparation process. The application should begin immediately after the hard steel troweling and the dissipation of the excess bleed water. A cure coat applied too late may render the slab highly permeable, leading to bondbreaker absorption and poor parting characteristics.

Typically, look for the following cure characteristics:

1. A well cured casting slab.
2. Excellent parting characteristics of the bondbreaker.
3. Good drying characteristics of the bondbreaker.
4. Clean appearance of the finished panel and floor slab.
5. Good compatibility with subsequent floor treatments and/or floor coverings.
6. Good compatibility with wall finishes such as paint, elastomeric coatings, sealants, adhesives, etc.

There are three basic types of bondbreakers:

1. Membrane forming.
2. Non-membrane forming — reactive.
3. Combinations of membrane forming and reactive.

Since the membrane forming materials rely on crude petroleum resins and waxes to form a water insoluble barrier between the freshly cast wall panel and the casting slab, they are prone to leave residue on both the panel and the slab. Under optimum conditions of temperature and sunlight, they will usually dissipate in approximately 90 days. Varying environmental and/or application conditions may result in residue being present much longer. Residue may discolor the concrete and interfere with subsequent surface treatments.

Reactive materials work with the excess lime available to create crude soaps. These soaps provide a moisture barrier to prevent the migration of the cement matrix into the casting slab.

Whenever there is doubt about sufficient bondbreaker on the casting slab, consider reapplication. Refer to the Dayton Superior brochure "*Use and Application of Bondbreakers*" for more information.

Panel Casting Layout

The panel contractor should consult with the erection contractor in the development of a good casting layout. For a smooth construction sequence, two important criteria must be met:

1. The panels should be located for efficient casting.
2. The panels should be located for safe and efficient erection.

Furthermore, the panel layout should provide accessibility to the panel forms for the ready mix trucks and crane.

Tilt-up panels should be cast as near as possible to their final location in the structure. An effort should be made to place as many side by side as possible. If a panel must be “walked” to its final position, try to keep the distance as short as possible. “Walking” the panels is not recommended.

Panel Construction

After the floor slab has been cleaned, the tilt-up panels are outlined directly on the floor slab with chalk. The chalk lines can be sprayed with a coat of bondbreaker to prevent rain from washing them away. The panel edge forms, and any opening forms can then be set in place.

Fog the casting area with clean, potable water prior to application of the bondbreaker. The fogging should saturate the slab, but any standing water must be removed before the bondbreaker is applied. The bondbreaker should be applied in a two-coat application; the first coat of the material sprayed in one direction, and the second coat sprayed perpendicular to the first. Be sure to let the first coat dry before applying the second coat. Applying the bondbreaker in this manner will help ensure a smooth, uniform coating.

Check the slab and bondbreaker before pouring any concrete. The slab should have a slightly tacky, soapy feeling. Bondbreaker can be tested by dropping a small amount of water on the casting bed, from a height of about 24" above the slab to allow it to splatter. If the bondbreaker is applied correctly, the water will bead into small droplets. If the water does not bead, respray all of the suspected areas of the casting slab.

When all of the panel preparations are complete and the panel is ready for placement of the concrete, the entire panel area should be fogged with potable water to be certain that the pores of the concrete slab have been properly saturated. Make sure there is no standing water, and proceed with the concrete placement.

The panel concrete must be properly consolidated using appropriate concrete vibration techniques. It is preferable to use the vibrator in an up and down motion. Laying the vibrator horizontal and dragging it along the reinforcing steel will often leave the pattern of the rebar visible on the down side face of the panel. Avoid overvibration; it may cause segregation of the aggregate and bring excess water to the surface.

Preparation for Lifting

Ensure the lifting area is clear from debris. Locate and prepare all pertinent embedded devices that are accessible. Do any dressing or patching that can be accomplished on the ground. Attach all pipe braces and strongbacks as required.

Each panel should be numbered and clearly identified according to the panel layout/erection sequence plan. Place the identifying mark in a position that will not be exposed when the structure is completed. The structure footing should also be marked with the corresponding identifying numbers to give the erection crew clear indication where each panel belongs. The footing should be appropriately marked to show the proper position of each panel on the footing.

All lifting inserts should be uncovered, cleaned out and tested with a hardware unit several days prior to erection day.

Panel Preparation

All standing water should be blown away from around the perimeter of the panel. Also, remove all water that might be pooled in panel openings. Standing water prevents air from entering under the panel and creates additional loading that must be overcome. These suction loads may cause the lifting inserts to become overloaded.

Panel preparations should also include checking the inserts for proper location, as shown in the erection details. It also includes removing the void former from the insert. All inserts should be checked with a lift hardware to make certain that the hardware can be properly attached to the lifting insert. Strongbacks should also be properly installed at this time.

The required compression strength of the concrete must be attained. The strength of concrete, noted in the erection instructions, refers to the concrete compressive strength at the time of lifting and not the ultimate or 28 day strength. This should be checked by an independent test lab using beam or cylinder tests.

Blockouts over interior footings should not be broken out prior to the lift, particularly in rainy weather. Water under the slab could make the subgrade weak. Projecting ledgers and reinforcing steel must be brought to the attention of all concerned. All bracing that is attached to the panel prior to the lift must be inspected for proper length and type.

The rigging details furnished by Dayton Superior in the erection details are not merely simple guidelines from which the erector can stray. THE RIGGING DETAILS DEFINE THE PROPER RIGGING FOR EACH PANEL FOR THE ERECTOR. Spreader bar widths and cable angles are integral parts of the erection stress analysis.

Proper cable lengths are important to the success of the lift.

The use of cables that are shorter than the prescribed length will increase stresses in the panel and could cause the panel to crack. If an erector has a problem with rigging details or cable lengths, as they are shown in the erection instructions, they should not take it upon themselves to change them. Instead, a call should be made to the technical service center from which the erection instructions originated and an alternate solution may be worked out depending on the individual situation.

Extra precautions should be taken when lifting panels with special shapes or special rigging. Erection instructions should be consulted for CAUTIONARY NOTES as to how a panel might act during lifting, and to again verify the rigging and the insert locations.

Panel Analysis

As the tilt-up panel is rotated from the horizontal to the vertical position, the panel is subjected to bending that causes both compressive and tensile stresses. These stresses developed must be resisted by the concrete, reinforcing steel, or a method of strongbacking that resists the initial bending stresses.

The lifting inserts are normally located so that the cantilevered portions of the panel sides or top will reduce the bending moments between lift points, thereby reducing the compressive and tensile stresses in the concrete.

Tilt-up panels are usually thin and designed by the Engineer of Record for the final in-place loading conditions only. Stresses in the panels induced by the erection process may be greater than in-place design stresses. Therefore, it may be necessary to allow some tensile stress in the concrete to be introduced during the lifting process. The value of allowable tensile stress in the concrete is a function of the modulus of rupture and the safety factor used. Please refer to Page 4 of this handbook regarding more information on this relationship.

Since the typical reinforcing in a panel is #4 bars at 12 in. o.c., both horizontally and vertically, it is important to be sure of the compressive strength of the concrete at the time of erection. In turn, the concrete must have sufficient tensile strength to provide the resisting strength necessary to erect the panels without cracking. This concrete quality can be obtained by having a proper mix proportion and a curing process that minimizes moisture loss. Strength tests using compression cylinders, Test Beam Break (modulus of rupture), or a Split Cylinder Test are methods of determining the value of the concrete strength and/or tensile strength of the concrete at the time of erection.

It is industry standard to have a minimum concrete compressive strength of 2,500 psi before the tilting operation commences. Generally, with this compressive strength, the ultimate tensile stress would be 375 psi or greater with an allowable stress of 300 psi. This assures a good tilting sequence with no cracking from tilting although some shrinkage cracks may appear.

Depending upon the quality of bond breaker used and the care taken in application, the amount of "bond" between the panel and the base slab can be from negligible to significant. Initially, a suction force must be overcome at the time of release from the base slab and estimates of this force vary considerably. Panel size, interface texture, and water between the panel face and the base slab all contribute to this additional load that is applied to the inserts and the surrounding concrete. ACI 551 recommends the use of a 1.25 factor be applied to the computed tension load at zero degrees to account for these additional loads.

Minor impact loads that occur during the tilting sequence generally do not create bending stresses in excess of the safety factor. However, if a panel suddenly drops and is caught by the slings, or hits the crane boom or some other obstruction, an increased load could be induced to the lift inserts.

Panels are analyzed for stresses at 0 degrees and at various angles during the tilting sequence. Panels with more than one horizontal row of pickup points are analyzed at angles of rotation due to the cable configuration changing the loads to the pickup points and therefore, changing the bending moments. The resultant stresses are compared to the allowable and if exceeded, additional reinforcing or strongbacks are added depending upon the contractor's preference.

After the tilt-up panels are analyzed vertically, they are examined horizontally. The procedure for horizontal analysis is similar to the vertical examination, except that a portion of the panel resting on the ground is not considered because of continuous support.

During the Lift – Precautions

Wind conditions must be considered prior to lifting a panel. Refer to the crane operation manual for operating in windy conditions. All spectators should be kept well away from the lift and not be allowed to interfere with the proceedings.

Panels should be inspected prior to lifting for any reinforcing steel and/or ledgers that may be projecting beyond the panel edges that will create interference when the panel is being plumbed next to a previously erected panel. (This happens most often at corners.)

After all attachments are made to the panel, and as the rigging is being raised to take the slack out of the cables, but prior to initial loading of the inserts, all rigging gear must be inspected for proper alignment and be free of snags. If non-swivel type sheaves are used, make certain the sheaves are properly aligned. As cables are being tensioned, they invariably tend to twist and possibly rotate the lifting hardware causing side loading on the hardware. The rigger foreman should be alert for this condition and if it does happen, SHOULD HALT THE LIFT AND REALIGN THE HARDWARE.

When braces are attached to the panel prior to lifting, caution must be taken to be certain the braces will not be trapped by the rigging when the panel is in the upright position.

When lifting the panels with the braces attached, it is the contractor's responsibility to assure that the braces are safely secured to the panel during erection. Provisions should be made to support the free end of the brace during erection to avoid contact with the floor slab, ground or other obstructions that could cause the brace to become unsecured from the panel. Also, care must be taken to assure that the brace does not swing more than 5 degrees from perpendicular to the face of the panel during erection.

Plumbing Panels – Precautions

Be alert when plumbing panels to their final upright position. Caution must be taken to make certain the panel being plumbed does not strike a previously erected panel. All personnel should be cleared of those critical areas around a panel when plumbing is being performed. If the panel being plumbed is a closure panel, measurements should be taken prior to lifting to make certain the panel will fit.

Tilt-up panels should be as plumb as possible prior to attaching the brace anchor. An out of plumb condition should not exceed the values stated in ACI 117-10.

Bracing – General

Do not release the crane load if, for any reason, the bracing does not appear adequate. Crane loads should always be released slowly, keeping an eye on the panel and bracing for any unusual activity. All bracing shall be complete before releasing the crane.

Erection Details

The engineering service (Erection Details) which is provided by Dayton Superior is a very important part of our bundled solution philosophy. Locations and selecting the proper lifting inserts, brace type and brace anchor locations, as well as the calculation of additional reinforcing steel or strongback size is critical for a safe and efficient panel erection.

Dayton Superior uses computer-aided design software to provide fast and accurate analysis of the stresses developed during erection. Erection detail booklets are furnished to the contractor showing lift insert locations, wall brace insert locations, crane riggings and cable lengths, reinforcing or strongback details, and specific assumptions relating to concrete strength and wind loads used in the brace design. These details are furnished at a nominal charge and are as important to the success of the operation as are the contract drawings. In order to provide these erection details to the tilt-up contractor, Dayton Superior needs the following information, but not limited to:

- Name of our dealer where you will purchase accessories.
- Name and address of project.
- Name of contractor.
- Job phone number.
- Name of job superintendent.
- Crane operator.
- Project plans with panel drawings.
- Number of buildings.
- Approximate number of panels.
- Number of detail booklets required.
- Date erection details required.
- Are copies of calculations required?
- Is engineer's stamp required?
- Type of inserts for tilting, bracing and strongbacking.
- Rigging type preferred for tilting.
- Are braces required? If so, what is the specified maximum wind load (psf)?
- Are panels to be braced to inside or outside of the building?
- Are panels cast inside face up or outside face up?
- Type and unit weight of concrete.
- Compressive strength of concrete at lift.
- Type and details of surface treatment.
- Special instructions not covered by the above items.

This, and other pertinent project information is detailed on the DSC Job Information Sheet (JIS). The DSC designer assigned to the project will inquire about this information and any other information necessary for the success of the project.

Computer-Aided Design Software

- All panels are entered in the computer-aided design software for analysis.
- Inserts are then positioned relative to the center of gravity.
- Panel dimensions and insert locations are checked by the computer for precise insert loading and flexural stress analysis.
- The bending moments and stresses in a panel are constantly changing as the panel rotates from 0° (horizontal) to approximately 90° (vertical).
- Stresses are checked at various degrees of rotation with respect to the horizontal.
- The most critical stress during lifting will normally occur somewhere between 20° and 50° of rotation.
- The calculations for determining the stresses at varying angles of rotation are extremely complex due to the cable geometry and the method of structural analysis required. This is accomplished most efficiently through utilizing the accuracy and speed of the computer-aided design software.
- As the cable, attached to the lifting plate, changes its angle during rotation, the force components on the lifting plate will vary causing the **tension** load on the insert to vary.
- When one insert's **tension** load increases, another insert's **tension** load may decrease. This is what causes the bending moments and stresses to vary throughout rotation of the panel.
- For example: the tension load at "B" in Fig. 3 is 100% tension and the tension load at "C" is 85% tension, but when rotated to 30° in Fig. 4, the tension load at "B" has decreased to 80% and the tension load at "C" has increased to 100%.
- To provide uniformity in panel detailing, Dayton Superior provides computerized or computer aided drafting graphics in addition to the stress analysis.
- The final results and output are analyzed by a DSC Engineer to determine the best design to meet the customer's requests, contract designs and constructibility.

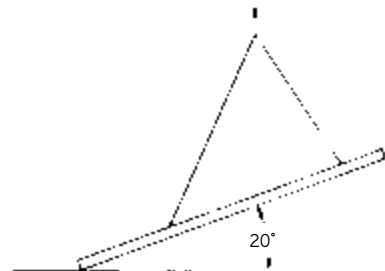

Fig. 1

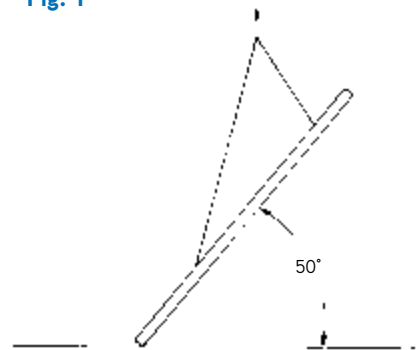

Fig. 2

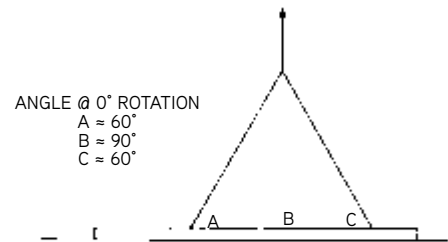

Fig. 3

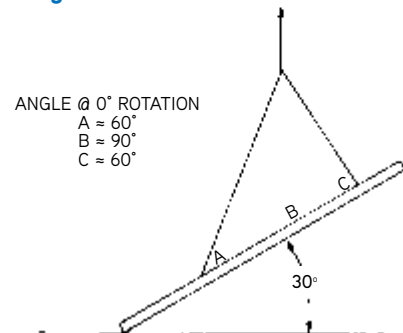
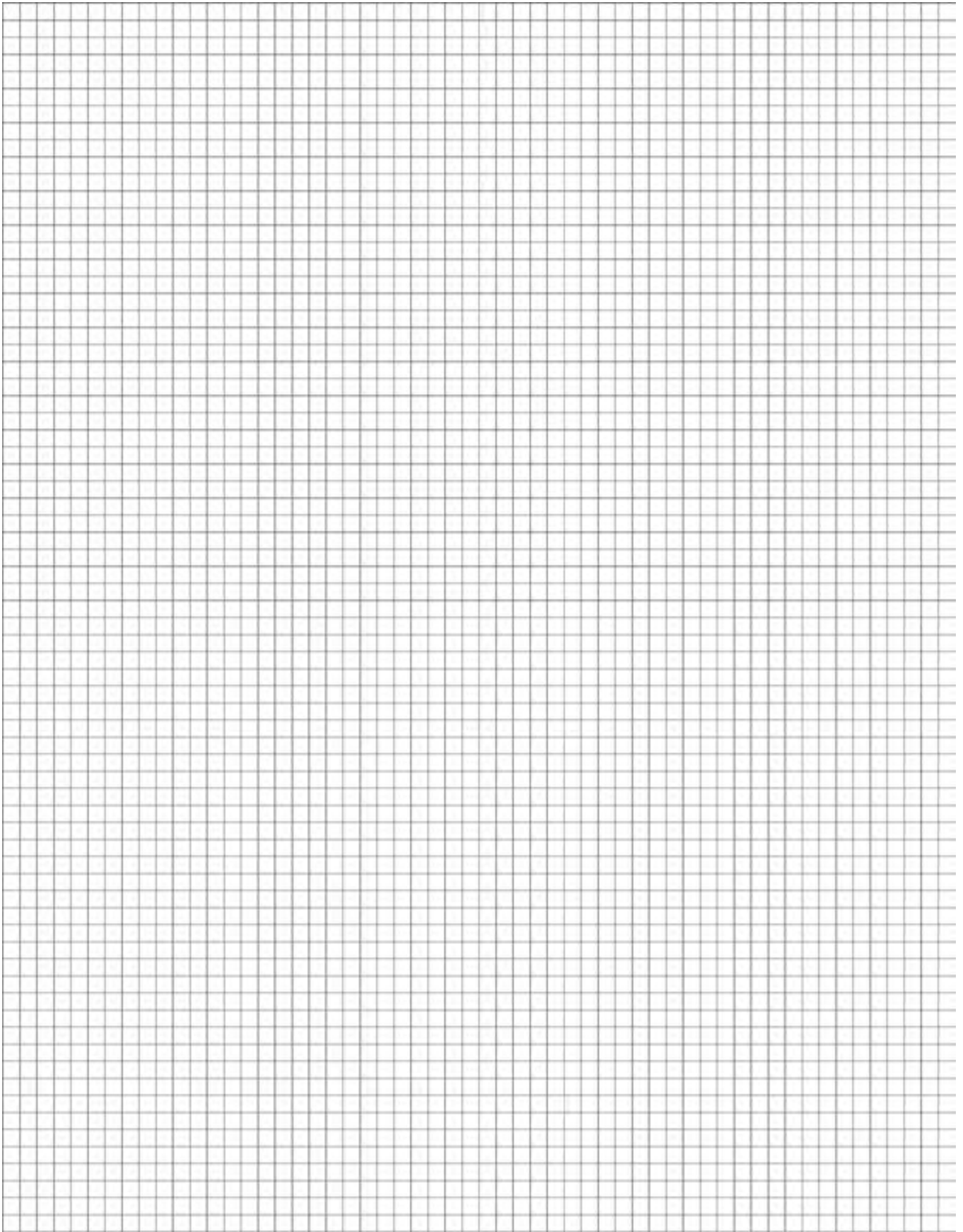

Fig. 4



Standard Rigging Details

Rigging is an integral factor in Dayton Superior erection stress analysis. Rigging used on the project must conform to the rigging pattern specified and shown on the panel layout sheet for that individual panel.

Use spreader and equalizer beams of such length that rigging cables are at a 90 ± 5 degree angle with the equalizer beams, unless otherwise shown or noted on the panel layout sheet.

The contractor must refer to the erection details for the minimum cable length to be used for each type of rigging specified. Using shorter cables than specified may overload inserts or crack panels.

Note: Contractor should follow crane and rigging requirements outlined in the current editions of OSHA, 29 CFR 1926

WARNING

Use of shorter cables or rigging patterns other than specified can cause insert failure, cracked panels, property damage, serious injury or death.

Cables must be of sufficient diameter to minimize stretch under load. Small diameter cables may have sufficient strength, but may stretch and cause the panel to bounce and result in increased insert loads.

WARNING

The factor of safety used in the lifting design for these tilt-up panels is based on the panel being handled one time. Lifting and/or handling a panel more than one time could lead to property damage, serious injury or death.

WARNING

For Two-Crane lifting operations, the contractor should use a certified crane operator/team that is qualified for Multi-Crane Lifting. Improper dual-rigged cranes may overload inserts resulting in property damage, serious injury or death.

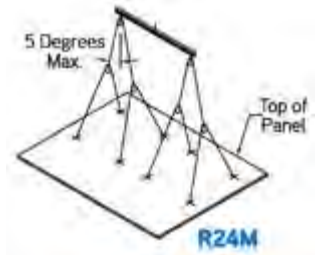
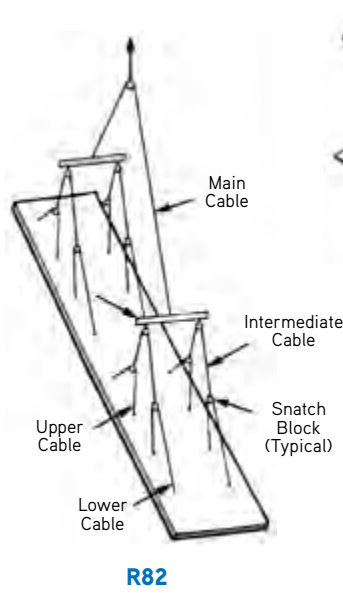
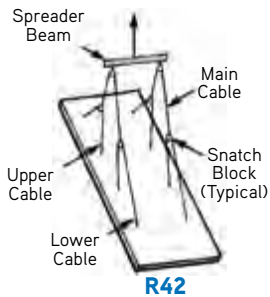
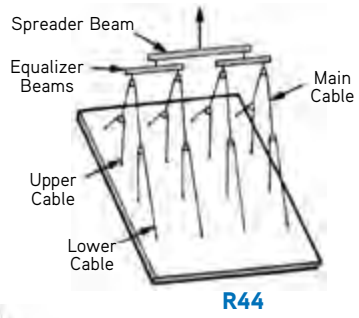
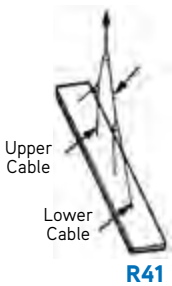
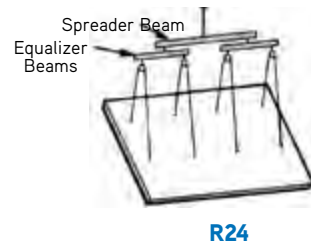
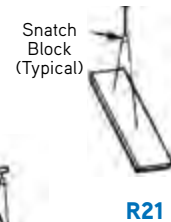
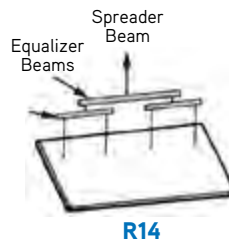
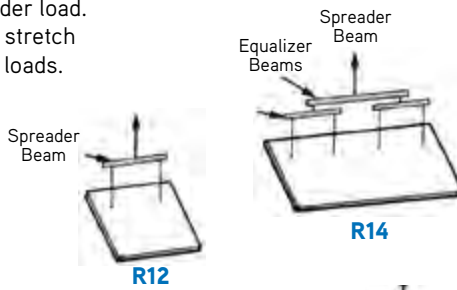
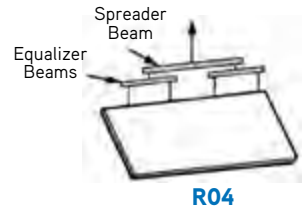
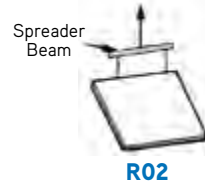

Boom Positioning

To safely erect a tilt-up panel, the crane boom must be directly over the panel's center of lift. If the boom is not correctly positioned the inserts may have different loads than calculated in the erection analysis and the stresses in the panel will be greater than anticipated. If insert loads or panel stresses become too large, an insert will pull out of the concrete or the panel will crack.

When the crane boom is set toward the bottom of the panel (under-booming) as the panel is erected, the panel will slide backwards. When the crane boom is set toward the top of the panel (over-booming) as the panel is erected, the panel will slide forward.

When a panel slides due to excessive under-booming or over-booming, it is possible for someone to be trapped between panels, between the panel and the crane, between panel braces, etc.

NOTE: Rigging may vary from that shown.

WARNING
<p>Incorrect placement of the crane boom can cause over-stressing of the panel/inserts and possible sliding of the panel. Failure to correctly position the crane boom can cause property damage, serious injury or death.</p>

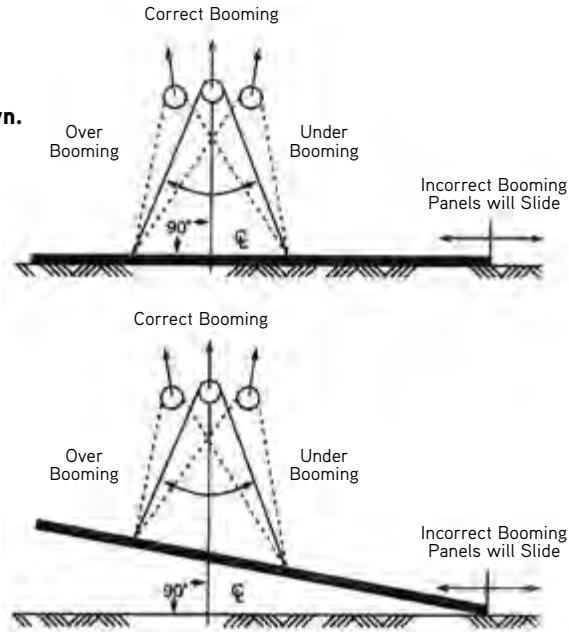

Plumbing Face-Lifted Panels

When a tilt-up panel is too tall to erect using edge lift inserts and the panel must hang as plumb as possible for setting, there are two standard methods available for use. One is the "brace and re-rig" method and the second is the "transfer" method.

Brace and Re-Rig Method

The “brace and re-rig” method is used when a crane does not have a second line that can safely carry the required panel weight. This method requires you to:

1. Erect the panel using the face lift inserts only.
2. Brace the panel as detailed.
3. Release the face lift hardware and rigging.
4. Reinstall the proper hardware and rigging onto the final set inserts.
5. With the rigging tight, remove the bracing.
6. Lift and set the panel into its final position.
7. Brace the panel as detailed.
8. Remove the final set lifting hardware and rigging.

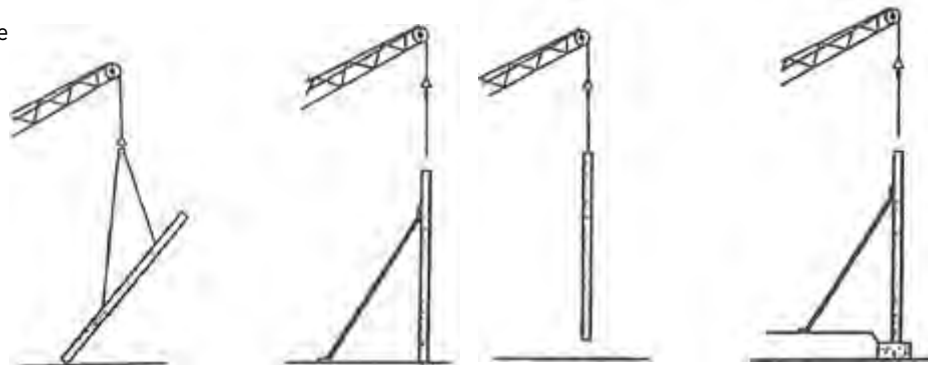

- | | |
|---|---|
| <ol style="list-style-type: none"> 1. Lift Panel With Face Lift Inserts 2. Brace Panel 3. Release Hardware | <ol style="list-style-type: none"> 4. Re-Rig Panel 5. Remove Bracing 6. Lift and Set Panel 7. Set and Brace 8. Remove Hardware |
|---|---|

NOTE: Rigging may vary from that shown.

WARNING

Failure to properly brace panels before releasing lifting hardware may cause failures resulting in injury or death.

Transfer Method

The “transfer” method is generally used when the crane has a second line that can safely carry the total panel weight. Using the transfer method requires:

1. That the panels be lifted to the vertical position using the face lift inserts and rigging only.
2. Keeping the rigging attached to the final set inserts slack with the final set hardware properly aligned with the cables.
3. After the panel is vertical and completely in the air, transfer the total panel load to the crane line and rigging attached to the final set inserts.
4. The panel is then set into its final position.
5. Brace the panel as detailed.
6. Release both the face lift and final set lifting hardware and rigging.

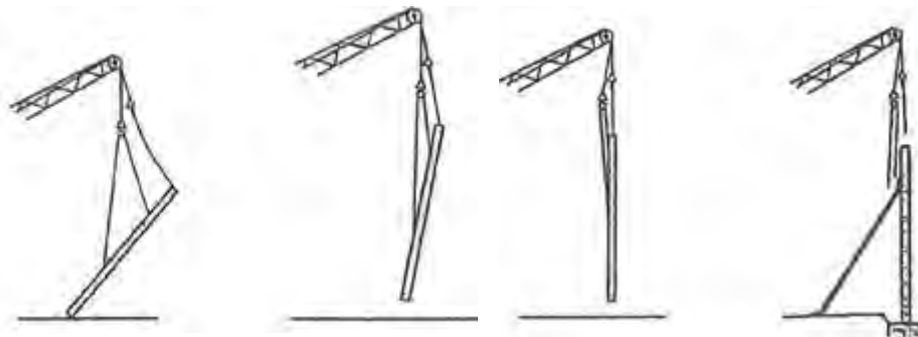

- | | |
|--|--|
| <ol style="list-style-type: none"> 1. Lift Panel Using Face Inserts 2. Edge Lift Rigging Remains Slack | <ol style="list-style-type: none"> 3. Transferring Load To Edge Lift Inserts 4. Load Transferred and Panel Set In Place 5. Brace As Detailed 6. Release Hardware |
|--|--|

NOTE: Rigging may vary from that shown.

WARNING

Failure to properly brace panels before releasing lifting hardware may cause failures resulting in injury or death.

Dayton Superior manufactures several lifting systems for Tilt-Up Construction. These systems are designed to meet the many job requirements found in the market. The project requirements along with the contractor's preference dictate which system is utilized on a project. Listed below is a brief description of the various options available to the contractor:

Superior Lifting System

This system features the T110 and T275 lifting inserts, capable of lifting up to 24,000 # SWL* per insert for face lifting and the T120 Superior Lifting Hardware for erection of the panels. The system is a ground release system, and typically used on larger, heavier panels. The insert is composed of a forged anchor with wire leg assembly for support and a plastic disposable void former. The insert is a directional insert used parallel to the height of the panel. For edge lifts, the Dayton P92P Erection Anchor with shear plate is utilized. This utilizes T120 Superior Lifting Hardware.

Ground Release II Lifting System

This system features the T41 Ground Release Insert capable of lifting up to 15,000 # SWL* per insert for face lifting and the T43L Ground Release Lifting Hardware for erection of the panels. This system is a ground release system typically used for panels up to 8" in thickness. The insert is a forged "dog bone" style insert with a plastic star base or wire base and a plastic disposable void former. The insert is a directional insert used parallel to the height of the panel. For edge lifts, the Dayton P52 Swift Lift[®] Anchor with shear bar is utilized. This anchor can utilize the same T43L hardware during the erection. This system is available in a 22,800 # SWL* System. See T81 Heavy Ground Release Insert.

Gyro Tilt Plus System

This system features the T49 Gyro Tilt Plus Face Insert capable of lifting up to 15,000 # SWL* per insert for face lifting and the T50 Gyro Tilt Plus Lifting Hardware for erection of the panels. This system is a ground release system typically used for panels up to 8" in thickness. The insert is a forged "dog bone" style insert with a wire leg assembly or plastic star base and a plastic disposable void former. This insert is a non-directional insert allowing complete rotation of the lifting hardware. For edge lifts, this system also uses the T49E Anchor (no base) with shear bar and the T50 Gyro Hardware during erection. This system is available in a 22,800 # SWL* System. See T52 Heavy Gyro Insert.

Coil Lifting System

This is the basic system employed during the original development years of tilt-up construction. This system uses the Dayton Superior T1 Pick-Up Insert along with B14 Coil Bolts and a variety of lifting hardware. The T1 Insert is available in 3/4" to 1-1/2" diameters, capable of lifting up to 14,000 # SWL* per insert. This system is utilized today with smaller applications and unique limited repetition panels. The T12 and T26 Lifting Hardware are used for erection of the panels.

***Note: See lifting system's respective Technical Data Sheet for rated lifting capacities based on panel thickness and concrete strength at time of lift.**

T110 Superior Lift System

The Dayton Superior T110 Superior Lift Insert consists of a forged foot anchor, 4-leg wire base and plastic void former. The insert is positioned with the void direction toward the top of the panel and then is tied in place to the rebar cage. The T120 Superior Lifting Hardware allows quick attachment to the insert and remote ground release after panel has been erected and braced. The T110 Superior Lift Inserts are shipped assembled, ready to go and are sized 1/8" less than the panel thickness.



T110 Superior Lift System



To Order:

Specify: (1) Quantity, (2) Name, (3) Panel Thickness, (4) bottom face aggregate or formliner thickness

Example:

150, T110 Superior Lift Inserts, 9" Panel with 1/2" formliner panel

Structural Panel Thickness	Anchor Length	Tension 2:1 2500psi	Shear 2:1 2500psi	Tension 2:1 3000psi	Shear 2:1 3000psi	Tension 2:1 3500psi	Shear 2:1 3500psi	Tension 2:1 4000psi	Shear 2:1 4000psi
5	3.625	11,600	12,400	12,700	13,580	13,720	14,660	14,670	15,680
5.5	4.125	13,000	13,400	14,240	14,670	15,380	15,840	16,440	16,940
6	4.625	14,300	14,800	15,660	16,210	16,900	17,500	18,080	18,720
6.5	5.125	15,700	16,400	17,190	17,960	18,560	19,400	19,850	20,740
7	5.625	17,150	18,000	18,790	19,710	20,280	21,280	21,700	22,760
7.25	5.875	17,910	18,800	19,620	20,590	21,200	22,240	22,660	23,780
7.5	6.125	18,680	19,600	20,460	21,470	22,100	23,180	23,630	24,000
8	6.625	20,210	20,940	22,140	22,940	23,900	24,000	24,000	24,000
8.5	7.125	21,730	21,370	23,800	23,410	24,000	24,000	24,000	24,000
9	7.625	23,250	22,870	24,000	24,000	24,000	24,000	24,000	24,000
9.25	7.875	24,000	22,970	24,000	24,000	24,000	24,000	24,000	24,000
9.5	7.875	24,000	22,970	24,000	24,000	24,000	24,000	24,000	24,000
10	7.875	24,000	22,970	24,000	24,000	24,000	24,000	24,000	24,000
10.5	7.875	24,000	22,970	24,000	24,000	24,000	24,000	24,000	24,000
11	7.875	24,000	22,970	24,000	24,000	24,000	24,000	24,000	24,000
11.25	7.875	24,000	22,970	24,000	24,000	24,000	24,000	24,000	24,000
11.5	7.875	24,000	22,970	24,000	24,000	24,000	24,000	24,000	24,000
12	7.875	24,000	22,970	24,000	24,000	24,000	24,000	24,000	24,000

*Minimum edge distance is 15"

T110 Safe Working Loads with T46 HD at 18" Spacing

Structural Panel Thickness	Tension	Shear
	f'c=2,500 psi 2:1 S.F.	f'c=2,500 psi 2:1 S.F.
5"	23,200 lbs.	24,800 lbs.
5.5"	26,000 lbs.	26,800 lbs.
6"	28,600 lbs.	28,800 lbs.
6.5"	31,400 lbs.	30,600 lbs.
7" or greater	32,000 lbs.	32,000 lbs.

When using pairs of T110 anchors in up to 6.5" concrete panel thickness, the two shear cones will not intersect when they're spaced 18" apart (shear cone radius is typically 1.5x the depth of the anchor foot). For use with the T46 HD Special Spreader Bar. For deeper/thicker installations, the interaction between the two anchors would begin reducing the combined capacity to less than 2 times a single anchor. However, the 32,000 lb. capacity of the T46 will cap the system beyond 6.5" panel thickness (2 x 15,700 lbs.) to a maximum of 16,000 lbs. per anchor.

Note: The two anchors should be secured to each other and the rebar reinforcing grid at the required 18" on center spacing by wire tying with 2-40" length of #4 rebar either side of the anchors shafts or order double T110 inserts that come assembled at 18" o.c.

Note: The short length of rebar recommended is an aid to prevent the insert from moving during concrete placement. When this rebar is added for insert stability, it should be placed against the vertical portion of the insert and at least 1" away from the insert's foot.

P99P Fleet Patch

The P99P Fleet Patch is a durable plastic patch designed to quickly cover T110 Superior Lift setting plug recesses. It is fabricated from an additive stabilized polypropylene to maintain the patch's slightly convex shape. The convex shape helps to keep a constant gripping pressure after installation. The patch is supplied in a concrete gray color with a matte finish that allows subsequent painting, if desired.

Fleet Patch Advantages:

- Special shape-holding composition
- Fast, one-piece "push-on" installation
- Paintable concrete gray matte finish
- Full eight (8) inch diameter
- Weather and chemical resistant
- Self adjusting grippers

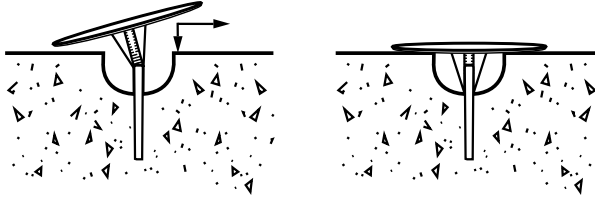

P99P Fleet Patch

The P99P Fleet Patch is a high quality, one piece plastic patch that is easy to install and maintain. It provides a quick and economical solution to covering Fleet-Lift anchor recesses.

Fleet Patch

Sales Category	Product Code	Wt. for 100
P99P	FL612	24 lbs.

To Order:

Specify: (1) quantity, (2) name, (3) product code.

Example:

200, P99P Fleet Patch, FL612.

Typical P99P Fleet Patch Installation:

1. Start the patch grippers on the top edge of the anchor
2. Push the patch onto the anchor, flush with the concrete

Note: The P99P Fleet Patch will not prevent corrosion or rusting of an embedded anchor that is subjected to wet conditions. Spraying the anchor with a corrosion resistant compound and applying a bead of silicone around the underside of the patch will help prevent moisture penetration.

T275 Tilt-Up Anchor

The T275 Tilt Up Anchor consists of a dual forged foot anchor assembled with a plastic recess plug and two plastic supports. The insert is a directional insert used parallel to the height of the panel. They are shipped assembled, ready to install and sized to the panel thickness.

Concrete Strength/ Safety Factor	Safe Working Load	Structural Panel Thickness	
		7-1/4" - 9"	9-1/4" - 12"
2,500 psi concrete and 2:1 SF	Tension	20,100 lbs	24,000 lbs
	Shear	24,000 lbs	24,000 lbs
3,000 psi concrete and 2:1 SF	Tension	22,050 lbs	24,000 lbs
	Shear	24,000 lbs	24,000 lbs
4,000 psi concrete and 2:1 SF	Tension	24,000 lbs	24,000 lbs
	Shear	24,000 lbs	24,000 lbs

Note: Mechanical Capacity of steel anchor is 69,000 lbs in shear and 64,800 lbs in tension

To Order:

Specify:(1) Quantity, (2) Name, (3) Panel Thickness, (4) Product Code

Example:

150, T275 Tilt-Up Anchors, 7-1/4", 146553



T275 Tilt-Up Anchor

T275 Safe Working Loads with T46HD at 18" Spacing

Concrete Strength / Safety Factor	Safe Working Load	Structural Panel Thickness	
		7-1/4" to 9" – 2X T275 with T46HD	9-1/4" to 12" – 2X T275 with T46HD
2,500 psi concrete and 2:1 SF	Tension	25,925 lbs	30,950 lbs
	Shear	30,950 lbs	30,950 lbs
3,000 psi concrete and 2:1 SF	Tension	28,440 lbs	30,950 lbs
	Shear	30,950 lbs	30,950 lbs
4,000 psi concrete and 2:1 SF	Tension	30,950 lbs	30,950 lbs
	Shear	30,950 lbs	30,950 lbs

Note: The two anchors should be secured to each other and the rebar reinforcing grid at the required 18" on center spacing by wire tying with two 40" lengths of #4 rebar either side of the anchor shafts

Note: T275 Anchors cannot be used in concrete thicknesses less than 7-1/4".

Note: The short length of rebar recommended is an aid to prevent the insert from moving during concrete placement. When this rebar is added for insert stability, it should be placed against the vertical portion of the insert and at least 1" away from the insert's foot.



T275B Base Plates

The T275B Base Plate is molded from a PC/ABS engineered polymer and designed to allow T275 inserts to be used in insulated sandwich panels.

Features

- The patch is supplied in a concrete gray color
- Fast, “push-on” installation

Installation

1. Push base plate onto the anchor base
2. Two base plates are required for each anchor



T275B Base Plates

T275P Patch Cap

The T275P Patch Cap is molded from a PC/ABS engineered polymer and designed to quickly cover setting plug recesses of T275 or T110 tilt-up lifting inserts.

Features

- The patch is supplied in a concrete gray color with a matte finish that allows subsequent painting, if desired.
- Fast, one-piece “push-on” installation
- Weather and chemical resistant
- Oval shape: 4.3” x 9”

Installation

1. Start the patch grippers on the top edge of the Anchor
2. Push the patch onto the anchor and flush with the concrete



T275P Patch Cap

Note: The T275P Patch Cap will not prevent corrosion or rusting of an embedded anchor that is subjected to wet conditions. Spraying the anchor with a corrosion resistant compound and applying a bead of silicone around the underside of the patch will help prevent moisture penetration.

T120 Superior Lift Hardware

The Dayton Superior T120 Superior Lift Hardware is designed to easily attach to the insert by engaging the curved clutch handle into the opening in the anchor. The bail of the hardware is designed to readily align itself to the pull of the rigging. Once engaged and under load, it can not be disengaged by remote ground release until the load has been removed in lowering the rigging. The T120 is used for face or edge lift system conditions.

To Order:

Specify:(1) Quantity, (2) Name

Example:

8, T120 Superior Lift Hardware



Safety Notes:

Safe use of the Superior Lift System requires the inserts to be positioned so that the arrows on the direction label point to the top and bottom of the panel (parallel to the sides of the panel).

The inserts must be properly located in relation to edges, corners, openings and ledgers, and at distances allowing the development of a full concrete shear cone. Minimum distances are shown in the sketches above. Placing an insert closer to an edge than the minimums shown may reduce the effective concrete shear cone and reduce the insert's safe working load.

Lifting inserts must be properly wired in place so that the vertical axis of the insert is perpendicular to the panel surface. Care must be taken to avoid displacement of the inserts during concrete placement and screeding operations.

Do not weld to the Superior Lift Anchor as welding causes embrittlement and can result in premature failure.

Exposed Aggregate Panel Inserts

Tilt-up panels with exposed aggregate or formliner thickness are often cast face down. In these panels, the aggregate or formliner thickness and the structural thickness are required to determine correct insert height.



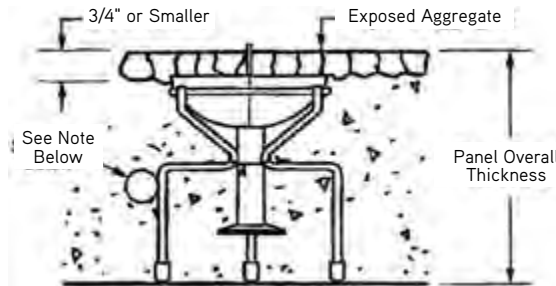
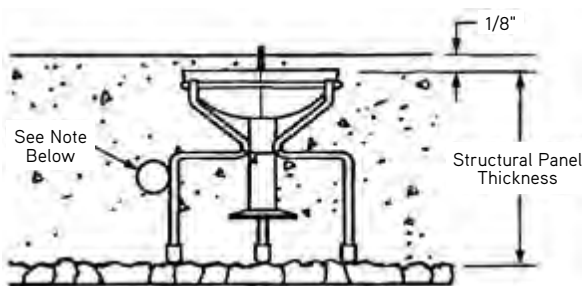





For panels exposed with aggregate face up, the overall thickness of the panel determines insert height.



NOTE: If attaching insert to rebar mat, it must be attached on vertical portion of the wire base leg as shown. DO NOT attach rebar to the horizontal portion of the wire base leg.

How to Remove the T110 Plastic Recess Plug

Lifting Systems

 <p>1. The T110 Insert's location in the panel is easily found by locating the antennae which will project through the surface of the concrete.</p>	 <p>2. Using an ordinary claw hammer, tap lightly around the antennae, breaking through the thin skin of concrete to expose the insert. Avoid striking the concrete too hard to avoid breaking through the plastic recess plug.</p>	 <p>3. Drive the claws of the hammer down about 3/8" between the end of the recess plug and the concrete.</p>
 <p>4. Pry up on the end of the recess plug until one half of it pops up to a point where it is about one third of the way out of the concrete. For the time being, leave it as it is and proceed with step #5.</p>	 <p>5. Repeat steps #3 and #4 to loosen the opposite half of the recess plug.</p>	 <p>6. Grasp both halves of the recess plug between the thumb and finger and squeeze.</p>
 <p>7. Both halves of the recess plug should now be easily removed, exposing the insert.</p>	 <p>8. If one half of the recess plug should be hard to remove, drive the claws of the hammer as deeply as possible between the recess plug and the top of the insert, as shown above. Push forward on the hammer with one quick motion. This will remove the recess plug.</p>	 <p>9. Remove all debris from around the insert and the recess plug. The insert is now ready to receive the lifting hardware.</p> <p>Note: For proper hardware release do not "round" out void holes.</p>

Proper Hardware Usage

Prior to lifting any tilt-up panel, apply an initial load to the crane lines, making certain that the hardware is properly attached to the head of the T110 Insert and that the bail of the lifting hardware is aligned with the crane line.

Warning! Do not apply a sideward load to the bail of the lifting hardware.

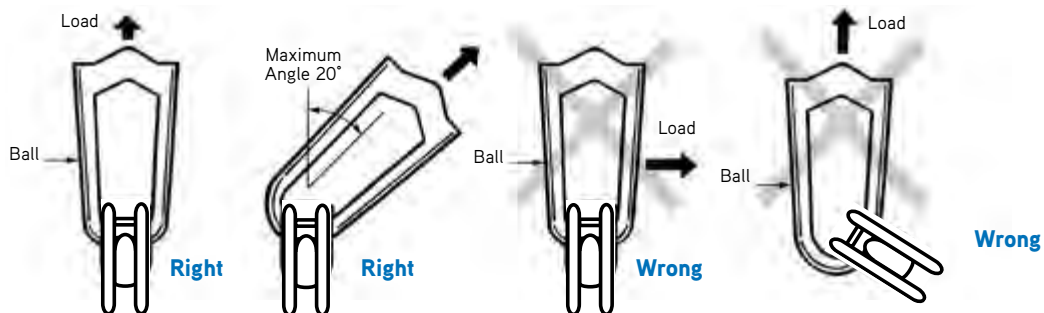

Warning! Do not modify, weld or alter in any way T120 Hardware units. Such actions could lead to premature failure of the hardware.

T120 Superior Lift Hardware Installation Sequence

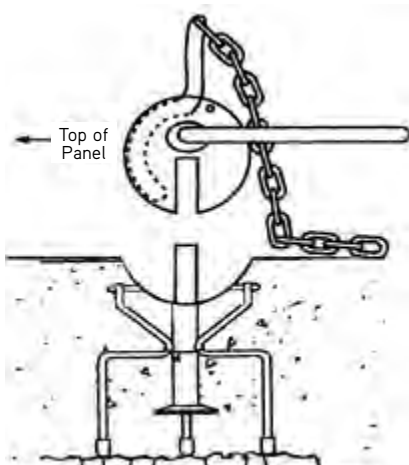
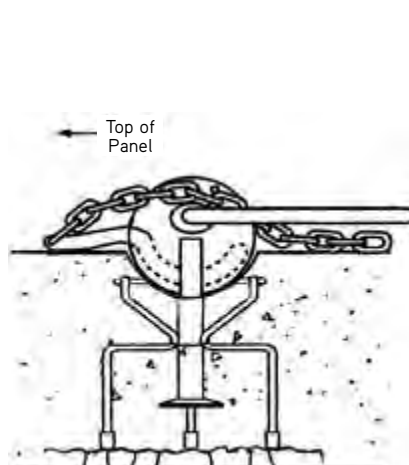
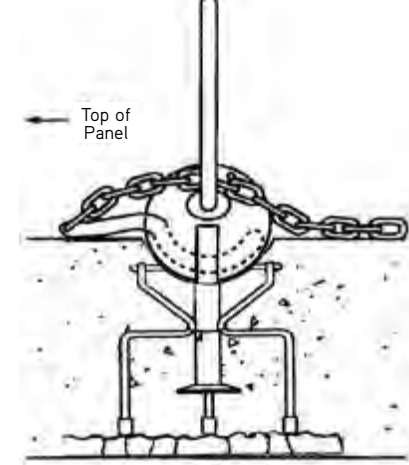
 <p>1. T120 Hardware in open position centered over the T110 Insert.</p>	 <p>2. The Hardware nestled in the Insert Recess and the Bolt/Release Arm engaged. The Bolt/Release Arm must contact the panel surface as shown in the sketch. Chip away excess concrete, if necessary, to nest the Bolt/Release Arm on the concrete surface. Contact a Dayton Superior Technical Service Center if unable to nest the Bolt/Release Arm on the face of the panel.</p>	 <p>3. The installation is complete. Erection may proceed.</p>
---	---	---

Lifting Systems

T120 Superior Lift Lifting Hardware Release Sequence

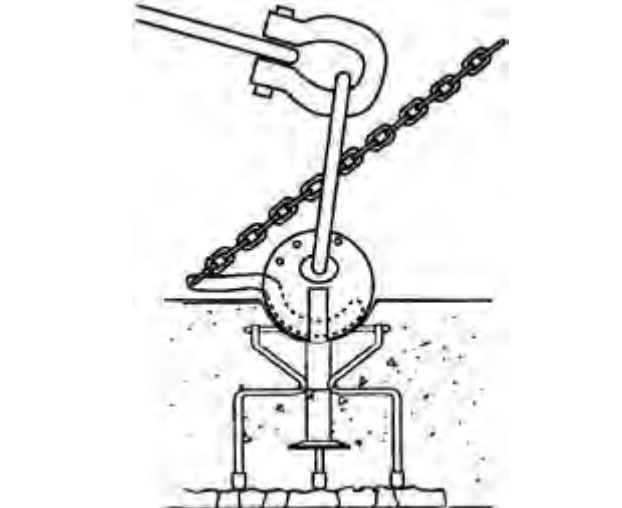
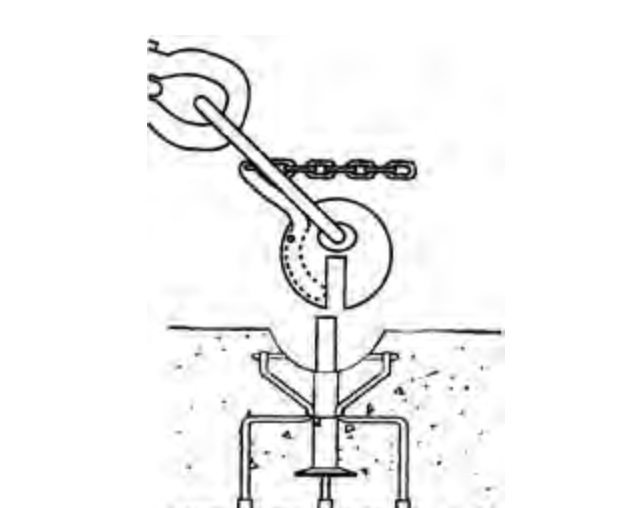
 <p>1. After the panel erection is complete and the panel has been properly braced/tied-off, the crane line should be relaxed slightly to permit the release of the lifting hardware.</p>	 <p>2. To Release the hardware, apply a quick, even downward force to the release line. The hardware stays attached to the crane line and is moved to the next panel.</p>
--	---

Note: Improper engagement of the lifting clutch could cause a lifting failure, potentially resulting in property damage, serious injury and/or death.

Note: If any lifting hardware appears damaged or inoperable. Do not proceed with lifting; contact Dayton Superior Immediately.

T110E Edge Lift Application

The P92P 8T x 13.25" Edge Lift Insert and P92FEW 10T x 12.75" are designed to be used with the T110 Superior Lift System for edge lift applications. These inserts have an integral shear plate for maximum transfer of shear loads into the concrete. These inserts use the P99D 8-10T Disposable Recess Plug for setting the insert. The T120 Hardware is used for erection with these inserts.

To Order:

Specify: (1) quantity, (2) name

Example:

20, P92P 8T FL149 Erection Anchor w/
SP20, P99D 8-12T FL068S Disposable
Recess Plug
or
20, P92FEW, P99D 8-12T FL068S
Disposable Recess Plug

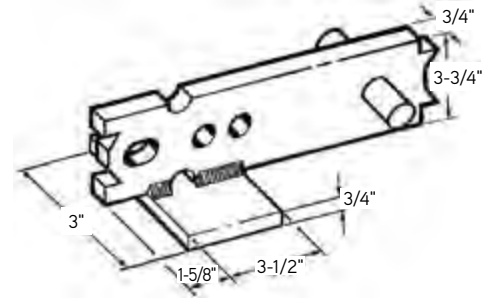
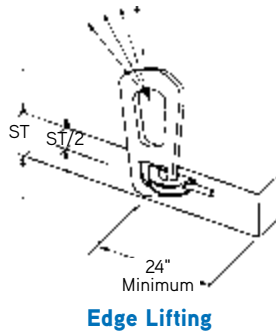

P92P



P92FEW

Lifting Systems

P92P Stamped Anchor

Structural Panel Thickness	SWL 2:1 Safety Factor		
	Shear (lbs)	Tension with Anchor Only (lbs)	Tension with #6 Tension Bar (lbs)
6"	6,760	9,432	24,000
7"	7,180	11,612	24,000
8"	7,560	13,142	24,000
9"	8,000	14,030	24,000
10"	8,300	14,875	24,000
11"	8,800	16,903	24,000
12"	9,200	19,100	24,000

*SWL provides approximate safety factor shown in chart with minimum 2500 psi normal weight concrete

P92FEW Forged Anchor

Structural Panel Thickness	SWL 2:1 Safety Factor		
	Shear (lbs)	Tension with Anchor Only (lbs)	Tension with #7 Tension Bar (lbs)
7.5"	7,775	24,000	24,000
8"	8,113	24,000	24,000
9"	9,212	24,000	24,000
10"	10,311	24,000	24,000
11"	11,494	24,000	24,000
12"	12,846	24,000	24,000

*SWL provides approximate safety factor shown in chart with minimum 2,500 psi normal weight concrete

P98T Fleet-Lift Tension Bar

The Dayton Superior P98T Fleet-Lift Tension Bar is used with various Fleet-Lift Anchors to provide a simple, inexpensive method of distributing tension forces (lifting) deep into the precast panel.

Anchor Tonnage	Tension Bar (Grade 60)	Length of P98T Tension Bar
6-ton or 8-ton	#6	66"
10-ton or 12-ton	#7	96"

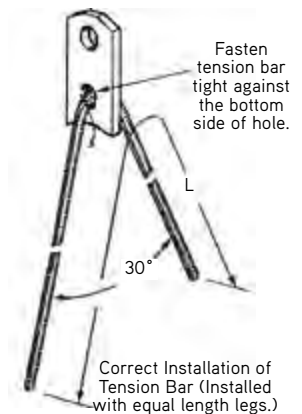

T41 Ground Release^{II} Insert

The Ground Release^{II} System is a unique method of erecting concrete tilt-up wall panels into position and allows the hardware to be easily released from the ground. Ladders are normally not required during the hardware release process, greatly increasing worker safety and productivity.

Features of the T41 Ground Release^{II} Insert Are

- **Flexible Plastic Antenna** folds over when screed passes, but springs back to indicate insert location.
- **Plastic Recess Plug** creates a void for attaching the Ground Release^{II} Lifting Hardware to the insert head. The expendable plastic recess plug is easily removed from hardened concrete.
- **Directional Label** indicates correct panel thickness and direction of plastic recess plug in relation to top and bottom of panel.
- **Ground Release^{II} Anchor.** This hot forged anchor permits rapid hardware attachment and allows smooth rotation of the hardware during the releasing operation.
- **Wire Frame** is standard used with T41 inserts. This provides a stable base that is easy to insert into rebar cage. A Plastic Support Base is available in situations where the insert is set on insulation or where there is concern of potential rust problems.
- **Ground Release^{II} Inserts** are shipped assembled, ready to use and are sized 1/8" less than the panel thickness. SWL of the insert listed below provides a safety factor of approximately 2 to 1 in 2,500 psi normal weight concrete.



T41 Ground Release^{II} Insert

Ground Release^{II} System

NOTE: Special inserts are available sized for panel thicknesses other than those listed in the chart below. When these special inserts are supplied, they will have the Ground Release^{II} Anchor suspended from a plastic tipped wire support chair instead of being supported by a plastic base.

T41 Single Ground Release ^{II} Insert Selection Chart							
Structural Panel Thickness	5"	5-1/2"	6"	6-1/2"	7"	7-1/2"	8"
Ground Release ^{II} Anchor Length	3-3/4"	4-1/4"	4 3/4"	5-1/4"	5-3/4"	5-3/4"	5-3/4"
Insert Safe Working Load (lbs.)	8,000	10,000	12,000	13,500	15,000	15,000	15,000

To Order:
Specify: (1) quantity, (2) type, (3) panel thickness, (4) bottomface exposed aggregate or foam formliner thickness

Example:
150 pcs., T41 Ground Release^{II} insert for 6" panel and 3/4" bottom face exposed aggregate.

Danger! Do not use for edge lifting of panels, as insert is not designed for such use. Do not use with top surface seeded exposed aggregate 3/4" or larger as aggregate will pop out during erection resulting in a reduced insert SWL.

See "Safety Notes and Product Applications" in General and Technical Information for reduction factors that must be applied to insert's SWL when using lightweight concrete.

T43L Ground Release^{II} Lifting Hardware

T43L Ground Release^{II} Lifting Hardware unit is a simplified design and when combined with our T41 Ground Release^{II} Insert provides you with a superior system for the quick and efficient erection of tilt-up concrete wall panels.

- Bail will accept all conventional crane attachments. Unit moves easily as it follows line of action of crane cable.
- Lifting Body attaches to head of insert.
- Release Line is a 1/2" hollow braided Polyethylene Cord of sufficient length to reach the ground.
- SWL is 15,000 lbs. with a factor of safety of 5 to 1.

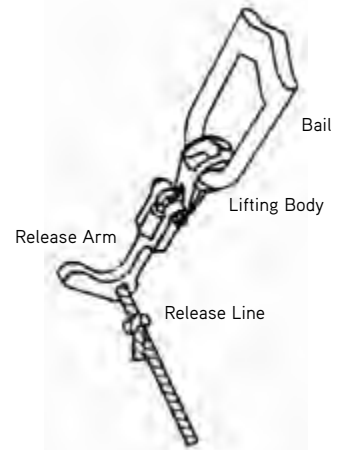

How to use the Ground Release^{II} System – T43L Hardware

Do Not Use This System On Top Surface, Seeded, Exposed Aggregate 3/4" or Larger.

Do Not Use for Edge Lifting

Precheck all insert holes with hardware prior to erection date, following instruction steps 2, 3 and 4, so that during tilting, proper hardware action is assured. See next page for proper procedure for removal of plastic recess plug.

Ground Release^{II} System

1. Install the insert so the directional arrow on the plastic recess plug points to the top or bottom of the panel. Wire tie the insert into position using a short length of additional reinforcing steel (rebar) placed tight against each side of the insert. Next, near each end of the plastic void former, secure a tie wire to one of the additional rebars, running the wire over the top of the plastic void former and back down, securing it to the additional rebar on the other side of the insert. Be sure to run the tie wire between the metal ring and the plastic void former as shown in the sketch to the right.

Note: The short length of rebar recommended is an aid to prevent the insert from moving during concrete placement. When this rebar is added for insert stability, it should be placed against the vertical portion of the insert and at least 1" away from the insert's foot. This extra rebar is not required to develop the insert's safe working load.

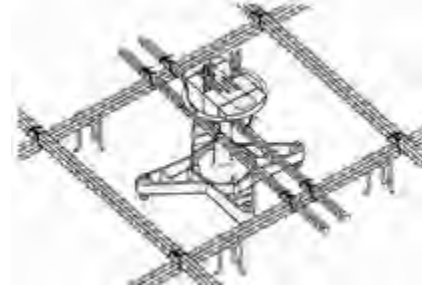

T43L Installation Sequence

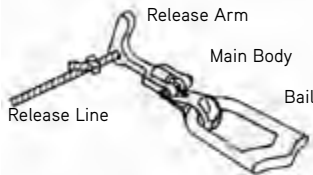

2. The various parts of the T43-L Ground Release^{II} Lifting Hardware are shown above.



3. To install the lifting hardware onto the insert, hold the hardware by the bail, release arm, and lower it onto the head of the insert. Check to make certain that the release arm points to the top of the panel.

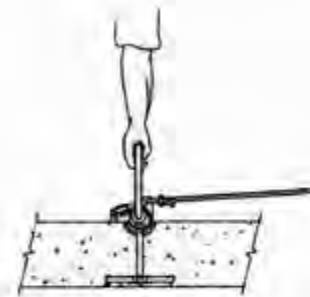

4. Lower the release arm parallel to the face of the panel. Lay the release line along side of the lifting hardware so that the line goes to the bottom of the panel. With the crane lines attached, the panel is now ready for lifting.

T43L Release Sequence



5. As the panel is lifted, friction from the load on the insert prevents the lifting hardware from prematurely releasing. Brace and secure the panel into position.

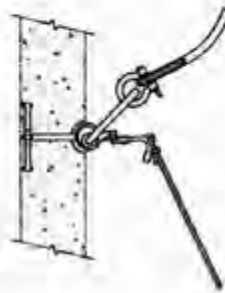



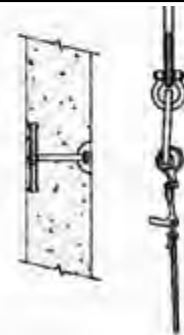





6. The crane line should be slackened slightly to permit the release of the lifting hardware. To release the lifting hardware, apply a single downward force to the release line.



7. The lifting hardware remains in the open position, ready to be lowered to the ground and attached to the next panel.

Danger! The crane line and bail of the lifting hardware must be turned in the direction of the cable forces before the lifting operation begins. The crane line must not be allowed to apply a sideward force on the bail, as this condition is dangerous and could lead to premature failure of the hardware or insert.

How to Remove the T41 Ground Release^{II} Plastic Recess Plug

 <p>1. The Ground Release^{II} Insert's location in the panel is easily found by locating the antennae which will project through the surface of the concrete.</p>	 <p>2. Using an ordinary claw hammer, tap lightly around the antennae, breaking through the thin skin of concrete to expose the insert. Avoid striking the concrete too hard to avoid breaking through the plastic recess plug.</p>	 <p>3. Drive the claws of the hammer down about 3/8" between the end of the recess plug and the concrete.</p>
 <p>4. Pry up on the end of the recess plug until one half of it pops up to a point where it is about one third of the way out of the concrete. For the time being, leave it as it is and proceed with step #5.</p>	 <p>5. Repeat steps #3 and #4 to loosen the opposite half of the recess plug.</p>	 <p>6. Grasp both halves of the recess plug between the thumb and finger and squeeze.</p>
 <p>7. Both halves of the recess plug should now be easily removed, exposing the insert.</p>	 <p>8. If one half of the recess plug should be hard to remove, drive the claws of the hammer as deeply as possible between the recess plug and the top of the insert, as shown above. Push forward on the hammer with one quick motion. This will remove the recess plug.</p>	 <p>9. Remove all debris from around the insert and the recess plug. The insert is now ready to receive the lifting hardware.</p> <p>Note: For proper hardware release do not "round" out void holes.</p>

Ground Release^{II} System

Proper Hardware Usage

Prior to lifting any tilt-up panel, apply an initial load to the crane lines, making certain that the hardware is properly attached to the head of the T41 Ground Release^{II} Insert and that the bail of the lifting hardware is aligned with the crane line.

Warning! Do not apply a sideward load to the bail of the lifting hardware.

Warning! Do not modify, weld or alter in any way T120 Hardware units. Such actions could lead to premature failure of the hardware.

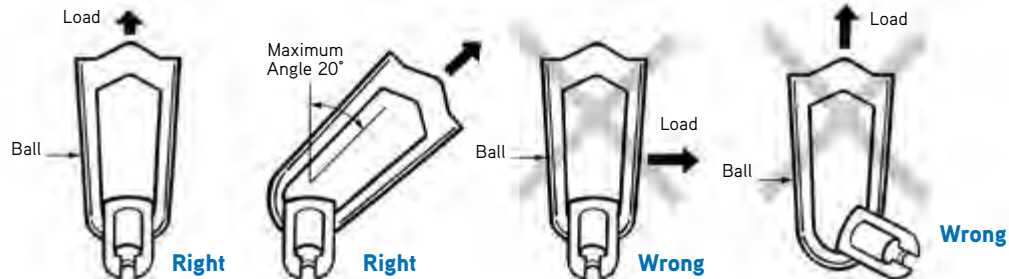

T42 Double Ground Release^{II} System

The Dayton Superior T42 Double Ground Release I System consists of two T41 Ground Release^{II} Inserts, two T43L Ground Release^{II} Hardware units and a T46 or T46HD Ground Release^{II} Spreader Beam with twin 8-1/2 ton shackles.

The two inserts are spaced on 12" to 18" centers to mate with the tandem hardware attached to the spreader beam. After lifting and positioning the panel, the hardware is released from the ground in the same manner as the basic system. The standard T46 has 12" center spacing while the T46HD has 18" center spacing.

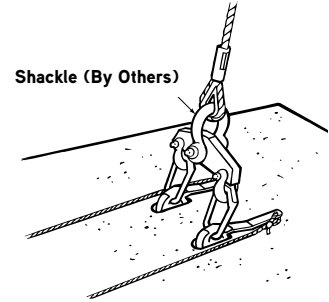

Shackle (By Others)

Available exclusively through Certified Dayton Tilt-Up Dealers.

Double Ground Release ^{II} Insert Selection Chart							
Structural Panel Thickness	5"	5-1/2"	6"	6-1/2"	7"	7-1/2"	8"
Ground Release ^{II} Anchor Length	3-3/4"	4-1/4"	4-3/4"	5-1/4"	5-3/4"	5-3/4"	5-3/4"
Insert Safe Working Load (lbs.)	13,000	15,000	17,000	19,000	22,000	24,000	26,000

Note: The two inserts must be spaced on 12" centers to develop the safe working loads displayed in the Chart.

SWL provides a safety factor of approximately 2 to 1 in 2,500 psi normal weight concrete.

See "Safe Working Load Reduction Factors for Lightweight Concrete" in General and Technical Information section for reduction factors that must be applied to insert's SWL when using lightweight concrete.

Ground Release^{II} System

T46HD Ground Release^{II} Spreader Beam with Twin Shackles

The Dayton Superior T46HD Ground Release^{II} Spreader Beam is supplied with two 8-1/2 ton shackles to attach the beam to two ground release inserts. Use of the T46HD spreader beam will simplify rigging change requirements on large or extremely heavy panels. The T46HD has a safe working load of 32,000 pounds with an approximate safety factor of 5 to 1.

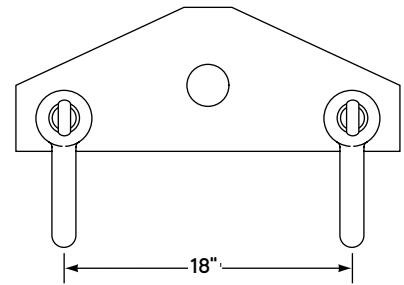

T46HD Ground Release^{II} Spreader Beam with Twin Shackles

Available exclusively through Certified Dayton Tilt-Up Dealers.

To Order:

Specify: (1) quantity, (2) name.

Example:

2, T46HD Ground Release^{II} Spreader Beams.

T45 Ground Release^{II} Patch Cap

The Dayton Superior T45 Ground Release^{II} Patch Cap is manufactured from ABS paintable plastic and provides a cosmetic alternative for patching insert holes. The T45 patch cap is available in concrete gray color only. It is easy to install by pushing it into the void. Friction holds the cap in place and the beveled flange assures a tight, flush fit. No grouting is required.

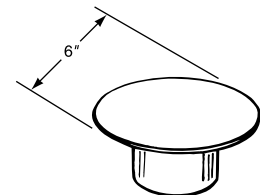

T45 Ground Release^{II} Patch Cap

Available exclusively through Certified Dayton Tilt-Up Dealers.

T81 Heavy Duty Ground Release^{II} Insert

The Dayton Superior T81 Heavy Duty Ground Release^{II} Insert is similar to the T41 insert but is designed to utilize a 1" diameter anchor. The insert is furnished with the anchor, wire base and plastic void former assembled and ready to use. The T81 insert is sized 1/8" less than the panel thickness and is equipped with antennae for quick locating.

T81 Heavy Duty Ground Release ^{II} Insert Selection Chart								
Structural Panel Thickness	8"	8-1/2"	9"	9-1/2"	10"	10-1/2"	11"	11-1/2"
Ground Release ^{II} Anchor Length	6-3/4"	7-1/8"	7-1/8"	7-1/8"	7-1/8"	7-1/8"	7-1/8"	10"
Insert Safe Working Load (lbs.)	15,500	18,200	18,200	19,100	20,000	20,900	21,800	22,800



T81 Heavy Duty Ground Release Insert

 Available exclusively through Certified Dayton Tilt-Up Dealers.

S.W.L. provides a safety factor of approximately 2 to 1 in 2,500 psi normal weight concrete

Ground Release^{II} System

To Order:

Specify: (1) quantity, (2) name, (3) panel thickness, (4) bottom face exposed aggregate or foam formliner thickness, if required.

Example:

150, T81 Heavy Duty Ground Release^{II} inserts for 10" panel with 3/4" exposed aggregate.

T83 Heavy Duty Ground Release^{II} Hardware

The Dayton Superior T83 Heavy Duty Ground Release^{II} Hardware is used with the T81 insert to lift and handle large tilt-up panels.

The high strength, efficient system offers quickness and safety.

Note: It is a good practice to have an extra hardware unit on the job site in case there is a need to replace one in use.

To Order:

Specify: (1) quantity, (2) name.

Example:

9, T83 Heavy Duty Ground Release^{II} Hardware units.



T83 Heavy Duty Ground Release^{II} Hardware

 Available exclusively through Certified Dayton Tilt-Up Dealers.

How to use the Ground Release^{II} System – T83 Hardware

Do Not Use For Edge Lifting

Do Not Use This System On Top Surface, Seeded, Exposed Aggregate 3/4" or Larger.

Precheck all insert holes with hardware prior to erection date, following instruction steps 2, 3 and 4, so that during tilting, proper hardware action is assured.

1. Install the insert so the directional arrow on the plastic recess plug points to the top or bottom of the panel. Wire tie the insert into position using a short length of additional reinforcing steel (rebar) placed tight against each side of the insert. Next, near each end of the plastic void former, secure a tie wire to one of the additional rebars, running the wire over the top of the plastic void former and back down, securing it to the additional rebar on the other side of the insert. Be sure to run the tie wire between the metal ring and the plastic void former as shown in the sketch to the right.

Note: The short length of rebar recommended is an aid to prevent the insert from moving during concrete placement. When this rebar is added for insert stability, it should be placed against the vertical portion of the insert and at least 1" away from the insert's foot. This extra rebar is not required to develop the insert's safe working load.

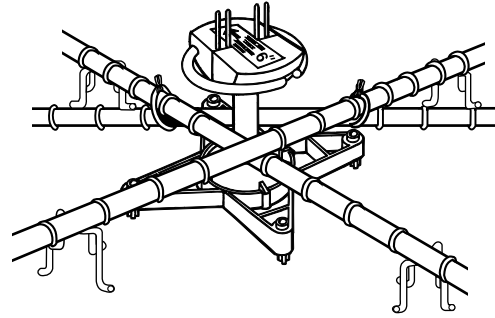

T83L Installation Sequence

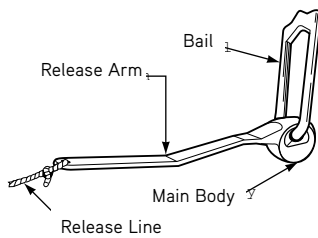

2. The various parts of the T83 Ground Release^{II} Lifting Hardware are shown above.

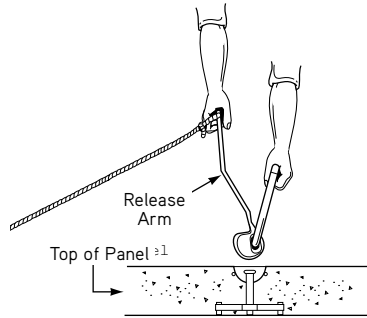

3. To install the lifting hardware onto the insert, hold the hardware by the bail, release arm, and lower it onto the head of the insert. Check to make certain that the release arm points to the top of the panel.

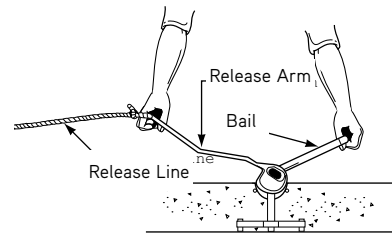

4. Lower the release arm parallel to the face of the panel. Lay the release line along side of the lifting hardware so that the line goes to the bottom of the panel. With the crane lines attached, the panel is now ready for lifting.

T83L Release Sequence

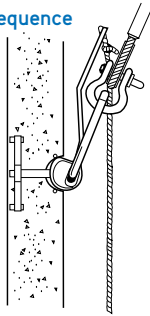

5. As the panel is lifted, the release arm is trapped between the panel and the crane line, which insures that the lifting hardware cannot be prematurely released. Brace and secure the panel into position.

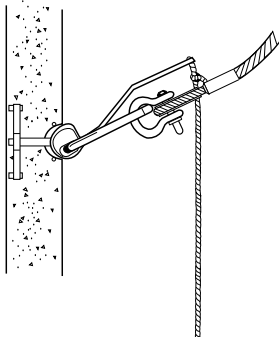

6. The crane line should be slackened slightly to permit the release of the lifting hardware. To release the lifting hardware, apply a single downward force to the release line.

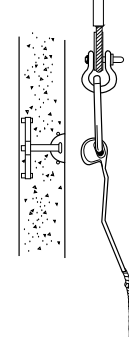

7. The lifting hardware remains in the open position, ready to be lowered to the ground and attached to the next panel.

Caution! The crane line and bail of the lifting hardware must be turned in the direction of the cable forces before the lifting operation begins. The crane line must not be allowed to apply a sideward force on the bail, as this condition is dangerous and could lead to premature failure of the hardware or insert.

P52 Swift Lift[®] Anchor (For Edge Lifting)

The Dayton Superior P52 Swift Lift Anchor is a hot forged insert available in 9/16" and 3/4" shaft sizes. The spherical head engages with the P51 hardware to lift and handle concrete panels. The standard lengths available for the 9/16" unit are 6-3/4" and 11". The standard lengths available for the 3/4" unit are 9-1/2" and 14". Other lengths are available on special order.

To Order:

Specify: (1) quantity, (2) name, (3) shaft diameter, (4) length.

Example:

200, P52 Swift Lift Anchors, 9/16" dia. x 11" long.

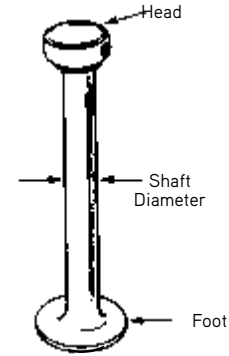

P52 Swift Lift Anchor

Caution: The Swift Lift anchor is designed to be used in conjunction with the P54 plug and P59 shear bar combination. Failure to use this combination may result in concrete spalling or premature failure.

Ground Release^{II} System

P54 Swift Lift[®] Recess Plug

The Dayton Superior P54 Swift Lift Recess Plug is fabricated from high density polyethylene plastic in two sizes to accommodate the P52 anchor, above. The two-piece design snaps together to securely hold the anchor. Built-in tabs are provided on the plug to hold the P59 Swift Lift Shear Bar, shown below.

To Order:

Specify: (1) quantity, (2) name, (3) shaft diameter.

Example:

200, P54 Swift Lift Recess Plugs for 9/16" shaft diameter.

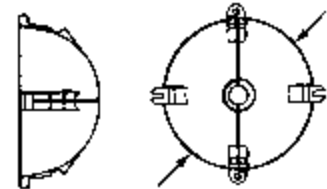

3" for 9/16" Diameter Anchors
3-3/4" for 3/4" Diameter Anchors

P54 Swift Lift Recess Plug

Caution! The Swift Lift recess plug is designed to be used in conjunction with the P52 insert and P59 shear bar combination. Failure to use this combination may result in concrete spalling or premature failure.

P59 Swift Lift[®] Shear Bar

The Dayton Superior P59 Swift Lift Shear Bar is designed for use with the P54 recess plug shown above.

For Use With Anchors Having	Wire Diameter	Overall Width
9/16" Shafts	.375"	24"
3/4" Shafts	.440"	30"

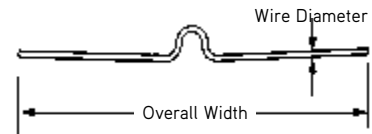

P59 Swift Lift Shear Bar

Note: This Shear Bar must be used for Tilt-Up applications.

To Order:

Specify: (1) quantity, (2) name, (3) size.

Example:

200, P59 Swift Lift Shear Bars, 3/4" diameter.

P52 Swift Lift Anchor Tension SWLs

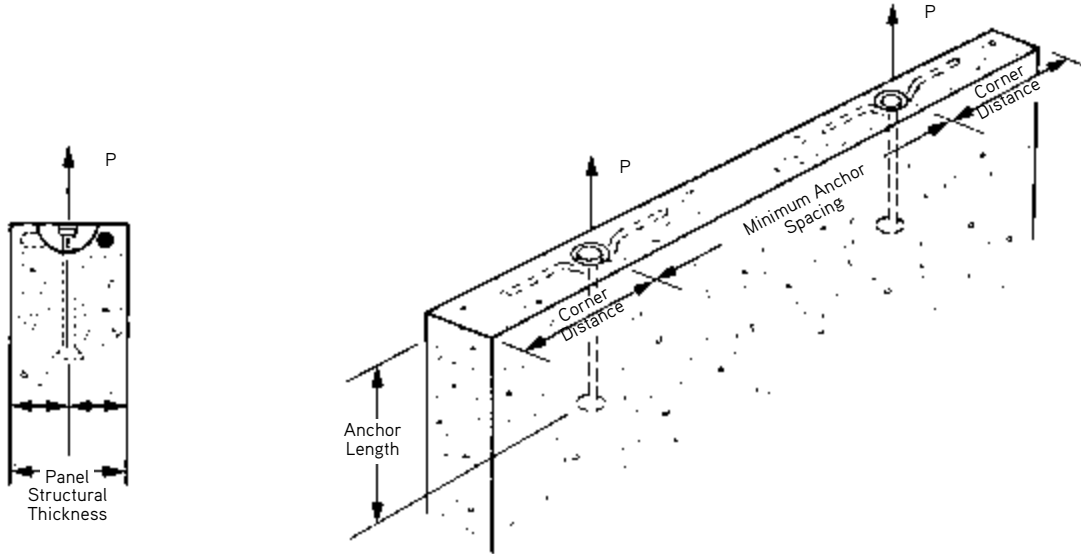

Ground Release^{II} System

The Swift Lift System is a quick connect-disconnect system that allows tilt-up panels to be edge lifted with speed, safety and economy. The system is a non-welded system and avoids threaded connections, that are time-consuming, subject to thread wear and damage, and contain the risk of not being fully engaged; consequently reducing the safe working load. The reusable SL Lifting Eye is free of these disadvantages and by virtue of its quality and heavy duty construction will give years of use.

The efficiency of the system has been proven by years of successful use and exhaustive laboratory tests. The components are subjected to regular batch testing during manufacturing.

The SL System is an ideal method to use when tilt-up panels must hang plumb for setting.

Shaft Dia. x Anchor Length	Panel Structural Thickness	Tension Safe Working Load per Anchor (lbs)		
		Corner Distance		Minimum Anchor Spacing
		20"	30"	
9/16" Dia. x 6-3/4" Long	4"	3,500	3,500	4'-0"
	5"	4,000	4,000	4'-0"
	6"	4,000	4,000	4'-0"
	7"	4,000	4,000	4'-0"
	8"	4,000	4,000	4'-0"
9/16" Dia. x 11" Long	4"	4,000	4,000	5'-6"
	5"	4,000	4,000	5'-6"
	6"	4,000	4,000	5'-6"
	7"	4,000	4,000	5'-6"
	8"	4,000	4,000	5'-6"

SWL's provide an approximate 2 to 1 factor of safety in 2,500 psi normal weight concrete. Safe Working Load is limited by Lifting Hardware capacity.

Caution! See "Safe Working Load Reduction factors for Lightweight Concrete" in General and Technical Information section for lightweight concrete SWL reduction factors.

Shaft Dia. x Anchor Length	Panel Structural Thickness	Tension Safe Working Load per Anchor (lbs)		
		Corner Distance		Minimum Anchor Spacing
		24"	30"	
3/4" Dia. x 9-1/2" Long	4"	4,700	5,000	5'-0"
	5"	5,900	6,200	5'-0"
	6"	7,000	7,500	5'-0"
	7"	8,000	8,000	5'-0"
	8"	8,000	8,000	5'-0"
3/4" Dia. x 14" Long	4"	7,200	7,800	7'-3"
	5"	8,000	8,000	7'-3"
	6"	8,000	8,000	7'-3"
	7"	8,000	8,000	7'-3"
	8"	8,000	8,000	7'-3"

SWL's provide an approximate 2 to 1 factor of safety in 2,500 psi normal weight concrete. Safe Working Load is limited by Lifting Hardware capacity.

Caution! See "Safe Working Load Reduction factors for Lightweight Concrete" in General and Technical Information section for lightweight concrete SWL reduction factors.

Swift Lift[®] Anchor Shear (Edge Lifting) SWLs

Swift Lift System is very useful for lifting tilt-up panels from the horizontal casting position to a vertical position. When the P52 SL Anchor is used under this shear loading condition, special shear bars must be positioned tightly against the recess plug as shown in the illustrations below to prevent the concrete from spalling and/or insert failure. The P59 Shear Bars **must** be used to develop the safe shear working loads shown below.

To develop the shear capacity of the P52 SL Anchor **the minimum spacing between two anchors is two times the corner distance.** When lifting panels to a vertical position, always check both shear SWL and tension SWL.

Anchor Shaft Diameter x Anchor Length	Panel Structural Thickness	Minimum Corner Distance	Shear Safe Working Load Per Anchor (lbs.)
9/16" Dia. x 6-3/4" or Longer	5"	20"	3,500
	5-1/2"	20"	4,000
	6"	20"	4,000
	7"	20"	4,000
3/4" Dia. x 9-1/2" or Longer	5-1/2"	24"	4,200
	6"	24"	4,400
	7"	24"	5,200
	8"	24"	5,600

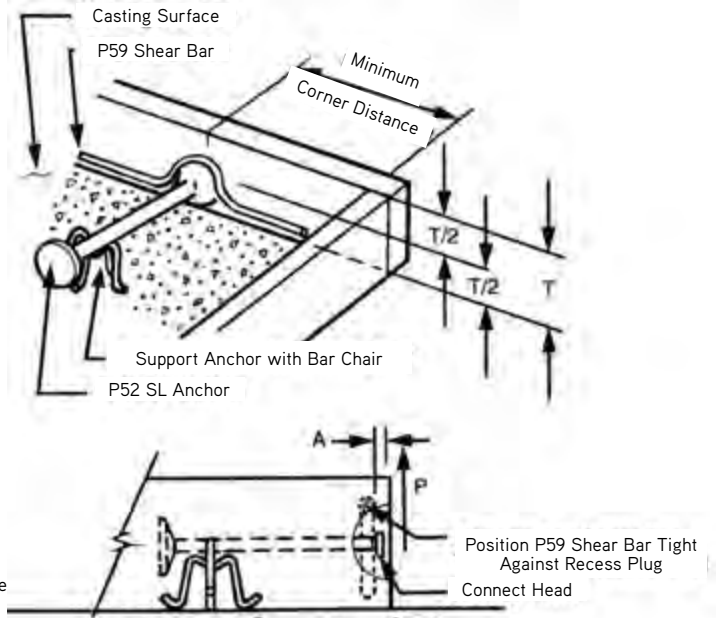

SWL provides a factor of safety of approximately 2 to 1 in 2,500 psi concrete. The above Shear Safe Working Loads are based on the use of P51 SL Lifting Eye only! DO NOT ATTEMPT to use any other type of lifting hardware when edge lifting of concrete panels using P52 Swift Lift Anchors. Safe Working Load is limited by Lifting Hardware capacity.

Caution! See "Safe Working Load Reduction factors for Lightweight Concrete" in General and Technical Information section for lightweight concrete SWL reduction factors.

Danger! Dayton Superior does not recommend the use of P52 SL Anchors without shear bars for edge lifting tilt-up panels. Spalling of the concrete above the anchor will result and the anchor could pull out of the concrete at lower than anticipated loads.

P59 Shear Bar Setback	
Anchor Shaft Diameter	A
9/16"	1/2"
3/4"	3/4"

Suggested Rigging Method

Dayton Superior recommends the use of this type of rigging when using the Swift Lift System for edge lifting tilt-up panels. 4-point rigging would be similar to the 2-point rigging shown.

Warning! The use of angular rigging will apply loads greater than those anticipated and should be avoided.

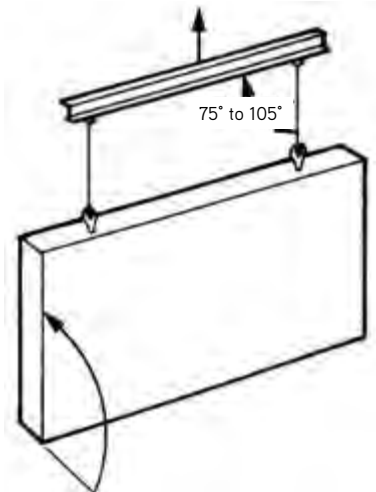

Ground Release^{II} System

How To Install the Swift Lift Anchor

Ground Release^{II} System

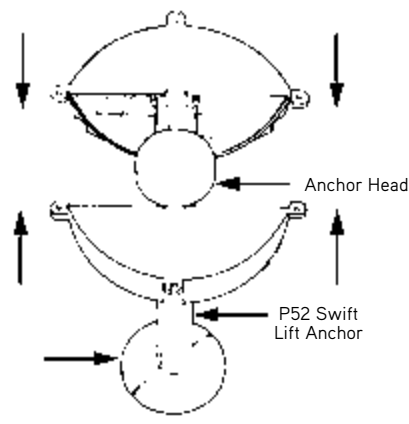
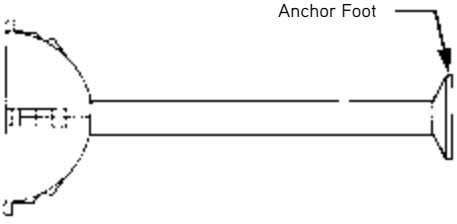
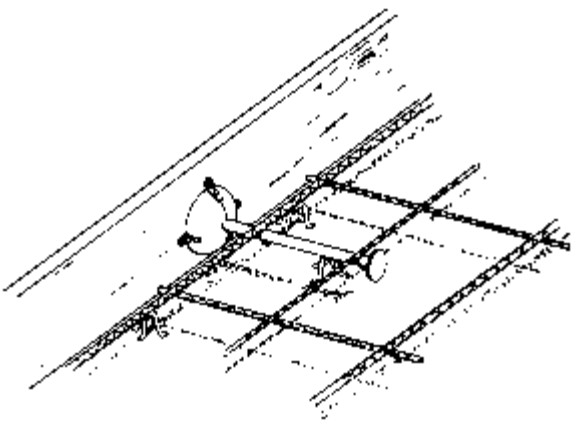
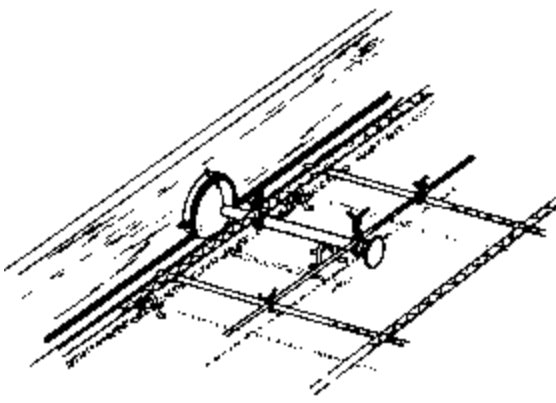
 <p>1. Assemble the P54 Recess Plug by placing the head of the P52 Swift Lift Anchor inside any two halves of the recess plug. Then snap the two halves together. It is very difficult to assemble the unit with the foot of the anchor inside the P54 Recess Plug and still get the two halves to close together correctly. If the two halves of the P54 Recess Plug do not fit closely together, it could be because the anchor is in upside down. In such a case, reverse the anchor and try again.</p>	 <p>2. A correctly assembled P54 Recess Plug and anchor.</p>
 <p>3. Attach the assembled P54 Recess Plug and anchor to the formwork in its predetermined location with the recess plug seam in the vertical position. Use common (not double headed) nails in the upper three tabs of the recess plug. The plug and anchor assembly can also be attached to the formwork by using a 2 ton stud and wingnut if desired. Provide bar supports around the anchor as shown to prevent displacement during the casting process.</p>	 <p>4. Slip the preformed shear bar onto the P54 Recess Plug as shown. The receiving tabs of the P54 Recess Plug will correctly position the shear bar. Usually, additional support wiring is not needed to hold the shear bar in place. However, prudent users will provide an additional wire tie or two to make certain the shear bar will not dislodge during concrete placement. Wire tie the P52 Swift Lift Anchor to reinforcing steel as shown.</p>

P53 Swift Lift[®] Eye Anchor - Edge Lifting

The Dayton Superior Swift Lift Eye Anchor (P53) is similar to the P52 anchor but has an eye at the foot to accept P60 Tension Bars. The P53 anchor is used primarily in thin sections, or thin panels of lightweight concrete. P53 anchors are available in 1, 2, 4, 8 and 20 T capacities and each has its load rating embossed on the head.

Note: P60 Tension Bar must be used with this anchor to achieve rated loads.



P53 Swift Lift Eye Anchor

To Order:

Specify: (1) quantity, (2) name, (3) system size, (4) length.

Example:

200, P53 Swift Lift Eye Anchors, 4 ton, 4-3/4" long

P53 Swift Lift Eye Anchor for Lifting and Handling

The P53 Swift Lift Eye Anchor is designed for use with the P60 Tension Bar placed through the eye of the anchor. This combination of Swift Lift Eye Anchor and P60 Tension Bar allows the anchor's full rated tensile load to be developed in thin, narrow wall applications. The anchor should be located at the center line of the wall. When two or more anchors are required, the minimum spacing between anchors must be equal to the minimum panel width.

The combination of P53 Swift Lift Eye Anchor and P60 Tension Bar is an excellent system to use for lifting, handling and plumb setting concrete panels.

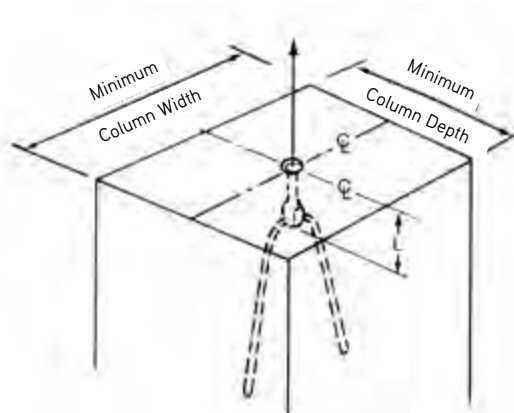
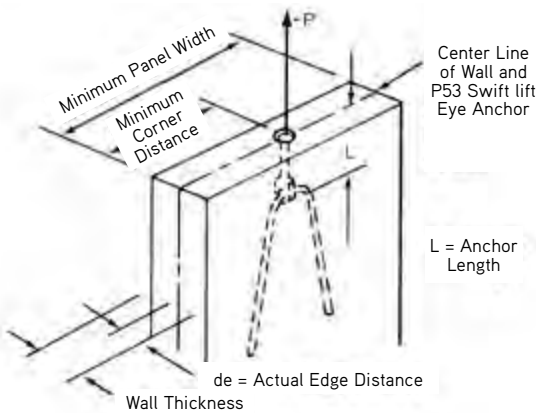

P53 Swift Lift Eye Anchor Selection Chart

Anchor Rated Load (Tons)	Anchor Length L	Minimum Thickness or Depth 2 de	Actual Edge Distance de	Minimum Corner Distance	Minimum Panel Width	Tensile Safe Working Load per Anchor 2,000 PSI *
1	2-1/2"	3"	1-1/2"	8"	16"	2,000 lbs.
2	3-1/2"	3"	1-1/2"	4"	8"	4,000 lbs.
4	4-3/4"	3-3/4"	1-7/8"	5"	10"	8,000 lbs.
8	7-1/16"	4-3/4"	2-3/8"	7"	14"	16,000 lbs.
20	9-7/8"	6-3/8"	6-3/4"	8-1/2"	17"	40,000 lbs.

*Safe Working Load provides a factor of safety of approximately 2 to 1 in 2,000 psi normal weight concrete. The P53 Eye Anchor must be used in conjunction with the P60 Tension Bar in order to develop its published rated working loads. Safe Working Load is limited by Lifting Hardware capacity.

Note: Contact Dayton Superior Technical Assistance for safe working loads when the P53 Eye Anchor is used with straight lengths of rebar.

P60 Swift Lift[®] Tension Bar

The Dayton Superior Swift Lift Tension Bar (P60) is designed to be used with the P53 Eye Anchor in order for the eye anchor to develop its published rated working loads. See P60 sizes and dimensions below.

To Order:

Specify: (1) quantity, (2) name, (3) anchor size, (4) concrete strength

Example:

200, P60 Swift Lift Tension Bar, 8 ton anchor, 3500psi concrete

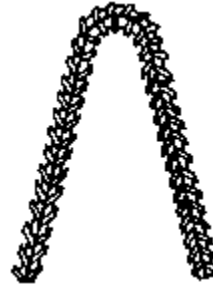

P60 Swift Lift Tension Bar

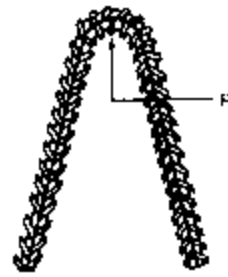
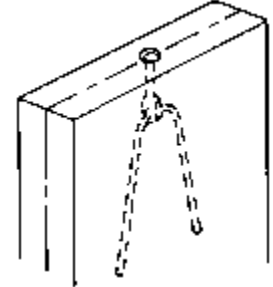

P60 Rebar Style

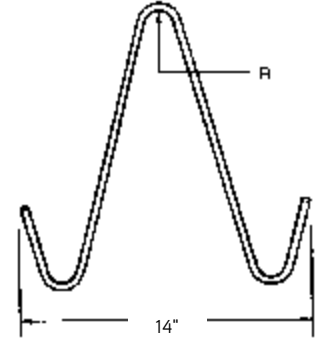

P60 Wire Style

Note: Wire style is for use with 1.3 ton P53 Eye Anchors only.

Ground Release^{II} System

Anchor Tonnage	Tension Bar (Gr. 60)	Dimension A*		Radius R	Overall Rebar Cut Length					
		Std.	Max.		2000 psi	2500 psi	3000 psi	3500 psi	4000 psi	5000 psi
1	.306 Wire	14"	--	3/4"	40"					
2	#3	5"	7-1/2"	1-1/8"	32"	29"	27"	24"	23"	21"
4	#5	6-1/4"	10"	1-7/8"	53"	48"	43"	40"	38"	34"
8	#6	9-1/2"	15"	2-1/4"	63"	57"	52"	48"	45"	40"
20	#9	12-1/2"	20"	3"	116"	104"	94"	88"	82"	74"

*Dimension A will be standard unless specified through MTO, up to the maximum dimension listed

P60 Swift Lift Tension Bar Installation

The proper installation of a tension bar is as follows:

1. Place the tension bar through the eye of the anchor in such a manner that the tension bar contacts the bottom of the eye.
2. Make certain the legs of the tension bar are equal on either side of the anchor.
3. Wire the tension bar into position so that the tension bar stays in contact with the bottom of the eye. (See sketch below.)

DO NOT attempt to use field-bent bars as a replacement for the Dayton Superior P60 Tension Bar. Field bending may result in an improperly shaped tension bar, an incorrect radius and/or a cracked bar. A problem, such as this, can cause the field-bent tension bar to fail prematurely.

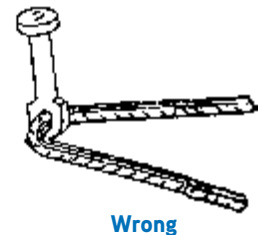
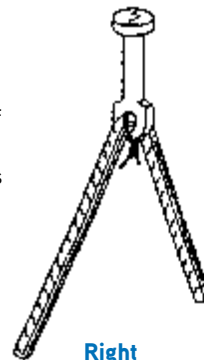

P51SL Lifting Eye – Edge Lifting in Shear Condition

The Dayton Superior P51SL Lifting Eye is a high quality steel casting. The P51 lifting eye fits into the recess formed by the recess plug and engages the spherical head of the P52 Swift Lift Anchor. The connection of the eye to the anchor can only be accomplished with the ball of the lifter facing the surface of the concrete. Accidental disengagement is prevented by a gravity actuated safety pin. The P51SL Lifting Eye is available in two sizes that are recommended for tilt-up edge lift applications. The 2 Ton unit that mates with the 9/16" diameter Swift Lift Anchor and the 4 Ton unit that utilizes the 3/4" diameter anchor.

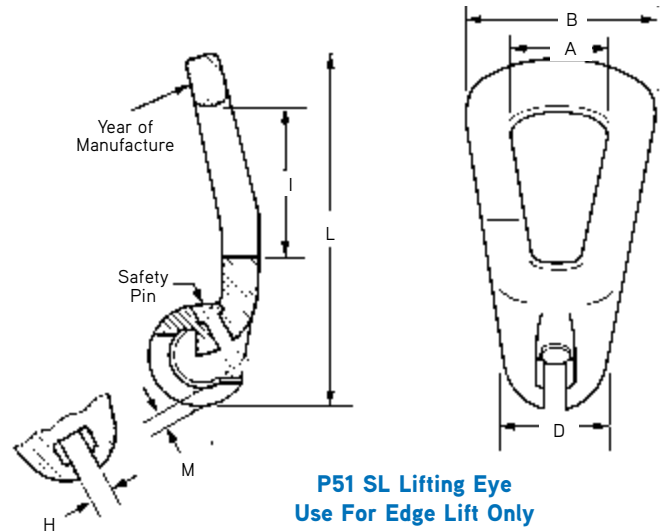

Ground Release^{II} System

To Order:
Specify: (1) quantity, (2) name, (3) size.

Example:
5, P51 SL Lifting Eyes, 4 Ton units

How to Use the P51SL Lifting Eye:

- Engage the lifting eye and the anchor.
- Rotate the lifting eye into the lifting position and attach the crane hook. See sketch above. When the lifting eye is rotated to the working position, the safety pin will drop into position to prevent accidental release of the lifter.

Do not use the P51SL Lifting Eye for face lift insert applications.

Inspection: The general condition and degree of wear of the P51 lifting eye should be checked on a regular basis, at least every three months. Areas of careful exam are shown as dimensions "H" and "M" in the sketch above. The maximum width of "H" and the minimum thickness of "M" are shown in the chart below. If either of these limits is exceeded, the unit must be removed from service and discarded. Also, check the safety pin to ensure that it is in good condition and moves freely. If the pin is worn or does not move freely, it must be replaced. Replacement pins are available.

Maintenance: The only maintenance on the P51 SL Lifting Eye is the replacement of the safety pin. No other repairs, alterations or welding are permitted.

Limiting Dimensions on P51SL Lifting Eye			General Information Dimensions of P51SL Lifting Eye				
Anchor Shaft Diameter	H Maximum Width	M Minimum Thickness	A	B	D	I	L
9/16"	.709"	.235"	2.64"	4.52"	2.36"	3.74"	8.43"
3/4"	.984"	.315"	3.00"	5.06"	2.83"	4.96"	10.35"

Caution! Do not attempt to lift with the P51 SL Lifting Eye if the unit has rotated from the correct working position (facing the concrete). Lifting with the hardware rotated will overload the anchor and may result in a premature failure.

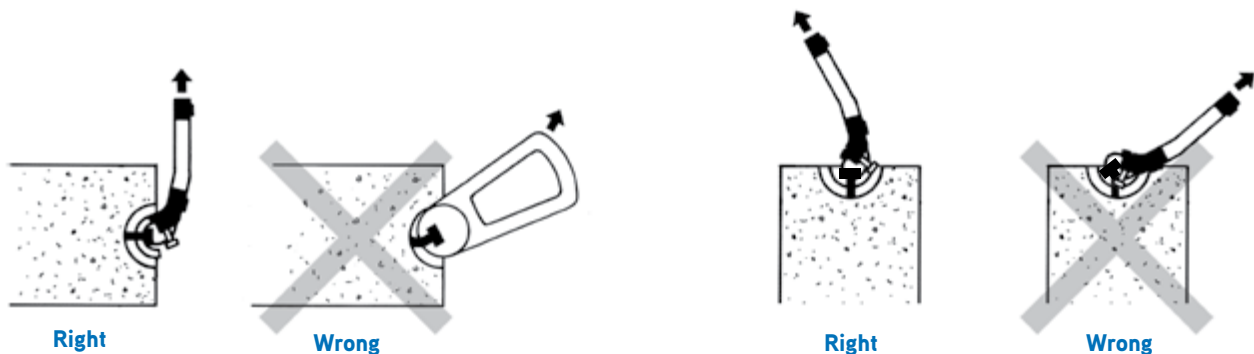

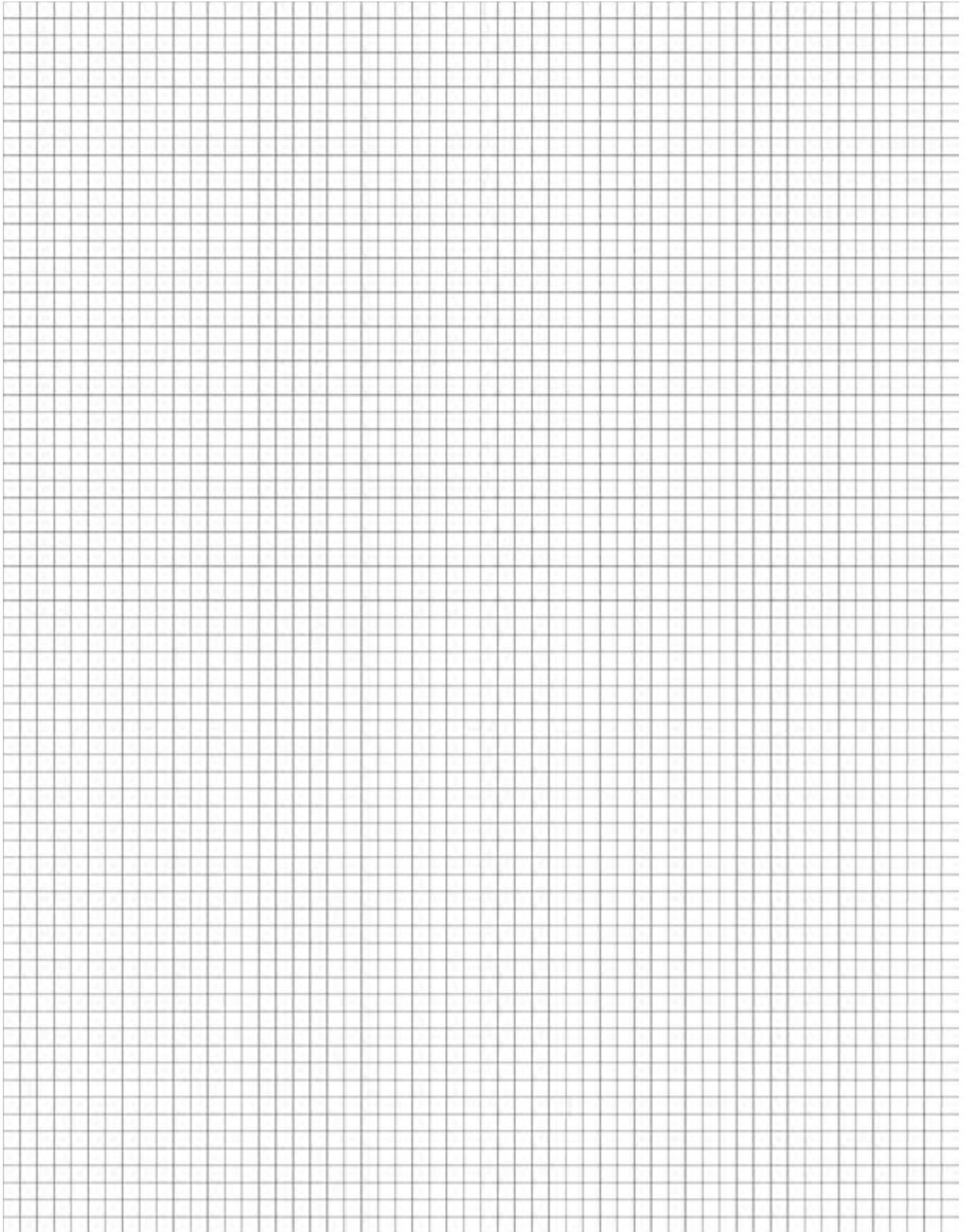

Gyro Tilt Plus™ System*

The Gyro Tilt Plus System is designed to quickly and efficiently lift and handle tilt-up panels and to be easily released from the ground. Ladders are seldom required when utilizing this system.

*U.S. Patent No. 4,703,595; 4,368,914 and 4,769,960.T49

Gyro Tilt Plus Face Lift Insert

The Dayton Superior T49 Gyro Tilt Plus Face Lift Insert is a 3/4" diameter insert manufactured from high quality steel. The hot forged head is engaged by the system hardware. The insert assembly is complete with a plastic void and plastic protected wire base. The insert assembly is easily positioned and tied to the rebar mat and requires no special orientation.



T49 Gyro Tilt Plus Face Lift Insert

Gyro Tilt™ Plus System

To Order:

Specify: (1) quantity, (2) name, (3) panel thickness, (4) bottom face exposed aggregate or formliner thickness.

Example:

150, T49 Gyro Tilt Plus™ Face Lift Inserts, 6" panel with 3/4" bottom face exposed aggregate

 Available exclusively through Certified Dayton Tilt-Up Dealers.

T49 Gyro Tilt Plus Face Lift Insert Selection Chart								
Structural Panel Thickness	5"	5-1/2"	6"	6-1/2"	7"	7-1/4"	7-1/2"	8"
Gyro Tilt Plus Anchor Length	3-3/4"	4-1/4"	4-3/4"	5-1/4"	5-3/4"	5-3/4"	5-3/4"	5-3/4"
Insert Safe Working Load (lbs.)	8,000	10,000	12,000	13,500	15,000	15,000	15,000	15,000

Caution! SWL provides a safety factor of approximately 2 to 1 in 2,500 psi normal weight concrete.

Note: Special inserts are available sized for panel thicknesses other than those listed in the chart above.

Caution! Do not use for edge lifting of panels, insert is not designed for such use. Do not use with top surface seeded exposed aggregate 3/4" or larger, aggregate will pop out during erection, resulting in a reduced insert SWL.

Note: See "Safe Working Load Reduction factors for Lightweight Concrete" in General and Technical Information section for reduction factors that must be applied to insert's SWL when using lightweight concrete.

T49E Gyro Tilt Plus Edge Lift Insert

The Dayton Superior T49E Gyro Tilt Plus Edge Lift Insert is the same basic insert as the face lift insert, but is furnished without the wire base and **must be used with the T51 Shear Bar**. This allows the plastic void to be nailed directly to the panel form. Standard T49E insert is 3/4" x 9-1/2", other lengths are available on request.

Gyro Tilt™ Plus System

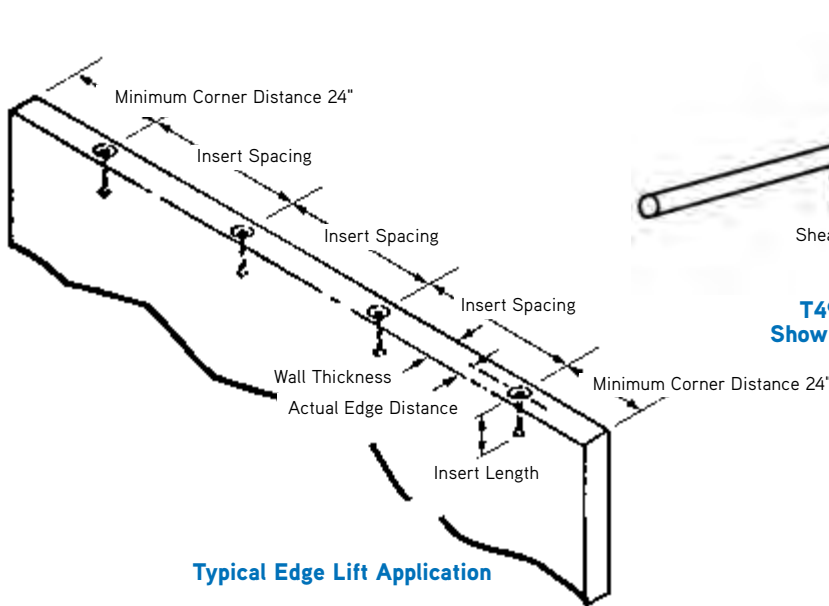

Typical Edge Lift Application

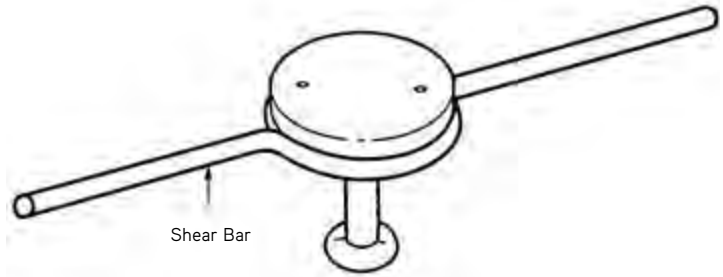

T49E Gyro Tilt Plus Edge Lift Insert Shown with mandatory shear bar in place

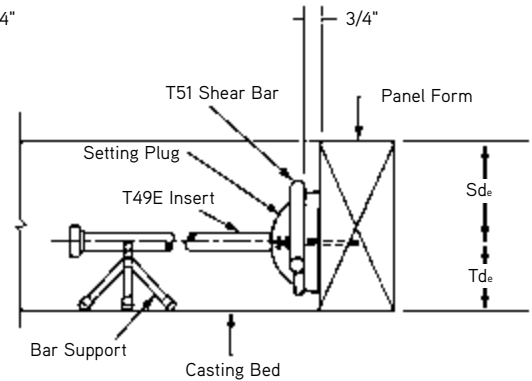

S_{de} = Minimum edge distance in the direction of applied shear load.

T_{de} = Minimum edge distance for tension loading.

Available exclusively through Certified Dayton Tilt-Up Dealers.

To Order:

Specify: (1) quantity, (2) name, (3) insert length.

Example:

100, T49-E Gyro Tilt Plus Edge Lift Insert, 9-1/2" long.

T49 Gyro Tilt Plus Edge Lift Insert – Safe Working Loads (lbs.)

Spacing Between Anchors	Panel Thk	4-1/2"	5"	6"	7"	8"
	S_{de}	2-1/4"	2-1/2"	3"	3-1/2"	4"
20"	Shear*	4,000	4,500	4,920	5,340	6,400
	Tension	4,000	5,000	6,000	6,800	8,000
30"	Shear*	4,000	4,500	4,920	5,340	6,400
	Tension	5,200	6,600	8,100	9,200	10,600
40"	Shear*	4,000	4,500	4,920	5,340	6,400
	Tension	6,200	7,800	9,700	11,100	12,500
50"	Shear*	4,000	4,500	4,920	5,340	6,400
	Tension	7,050	8,800	10,800	12,700	14,000
60"	Shear*	4,000	4,500	4,920	5,340	6,400
	Tension	7,800	9,300	11,300	13,400	15,100

Safe Working Loads reflect approx. 2:1 safety factor in normal weight 2,500 psi concrete.

See "Safe Working Load Reduction Factors for Lightweight Concrete" in the General and Technical Information section for lightweight concrete reduction factors.

Note: Edge lift applications require the use of the Gyro Tilt Plus T51 Shear Bar to develop the shear loads displayed in the chart.

*Shear loads are based on mandatory use of shear bar.

T50 Gyro Tilt Plus Hardware

The Dayton Superior T50 Gyro Tilt Plus Hardware is designed to accomplish the task of lifting and handling tilt-up panels quickly and efficiently. High safe working load, ease of operation and positive ground release provide tilt-up effectiveness.

To Order:

Specify: (1) quantity, (2) name.

Example:

8, T50 Gyro Tilt Plus Hardware.

T50 Gyro Tilt Plus Hardware

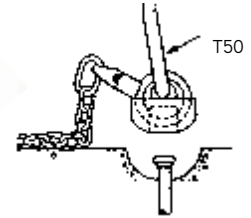

Typical Installation

Available exclusively through Certified Dayton Tilt-Up Dealers.

T51 Gyro Tilt Plus Shear Bar

The Dayton Superior T51 Gyro Tilt Plus Shear Bar can be used for erecting a tilt-up panel by spreading the shear loads over a wider area.

To Order:

Specify: (1) quantity, (2) name.

Example:

200, T51 Gyro Tilt Plus Shear Bars.

T51 Gyro Tilt Plus Shear Bar



Available exclusively through Certified Dayton Tilt-Up Dealers.

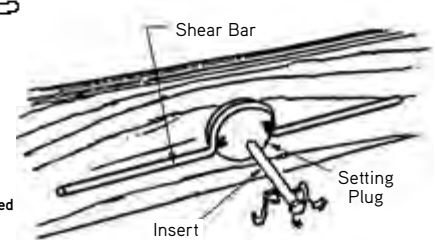

Edge Lift Insert Installation

T52 Heavy Duty Gyro Tilt Plus Insert

The Dayton Superior T52 Heavy Duty Gyro Tilt Plus Insert is similar to the design of the proven T49 insert. The T52 insert load capacity is made possible by the 1" diameter hot forged anchor. The insert assembly is furnished complete with a plastic void and plastic protected wire base. The assembly is easily positioned and wired to the rebar mat and requires no special orientation.

To Order:

Specify: (1) quantity, (2) name, (3) panel thickness.

Example:

200, T52 Heavy Duty Gyro Tilt Plus Face Lift Inserts for 10" panel thickness.

Available exclusively through Certified Dayton Tilt-Up Dealers.



T52 Heavy Duty Gyro Tilt Plus Insert

T52 Heavy Duty Gyro Tilt Plus Insert Selection Chart

Structural panel Thickness	8"	8-1/2"	9"	9-1/2"	10"	10-1/2"	11"	11-1/2"
Anchor Length	6-3/4"	6-3/4"	7-1/8"	7-1/8"	7-1/8"	7-1/8"	7-1/8"	10"
Insert Safe Working Load (lbs)	15,500	16,400	18,200	19,100	20,000	20,900	21,800	22,800

T53 Heavy Duty Gyro Tilt Plus Hardware

The Dayton Superior T53 Heavy Duty Gyro Tilt Plus Hardware is a strong, easy to use unit used in conjunction with the T52 insert to lift, handle and place heavy concrete tilt-up panels.

Note: It is a good practice to have an extra hardware unit on the job site in case there is a need to replace one in use.

To Order:

Specify: (1) quantity, (2) name.

Example:

8, Heavy Duty Gyro Tilt Plus Hardware units.

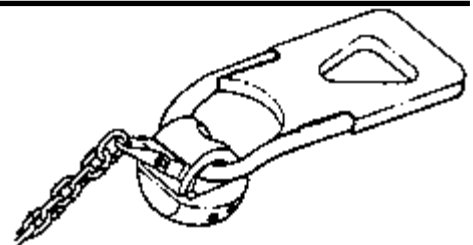

T53 Heavy Duty Gyro Tilt Plus Hardware

Available exclusively through Certified Dayton Tilt-Up Dealers.

Gyro Tilt™ Plus System

How to use the Gyro Tilt Plus System

Do Not Use Face Lift Insert For Edge Lifting

Do Not Use This System On Top Surface, Seeded, Exposed Aggregate 3/4" or Larger.

Precheck all insert holes with hardware prior to erection date following the instruction steps below. This is so that during tilting, proper hardware action is assured. See next page for proper procedure for removal of plastic recess plug.

Inserts Installation — T49 Gyro Tilt Plus Inserts are simply wired to the rebar mat at designated points. No special orientation is required, but reasonable care should be taken to assure that the insert is the correct height for the panel and remains perpendicular to the panel face during concrete placement.

Note: The short length of rebar recommended is an aid to prevent the insert from moving during concrete placement. When this rebar is added for insert stability, it should be placed against the vertical portion of the insert and at least 1" away from the insert's foot. This extra rebar is not required to develop the insert's safe working load.

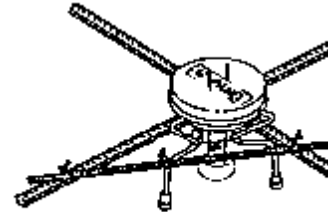

Gyro Tilt™ Plus System

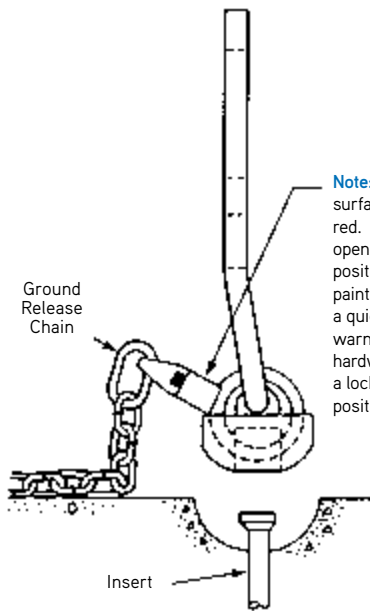

Note: This surface is painted red. In the open (unlocked) position, the red paint provides a quick, visual warning that the hardware is not in a locked (lifting) position.

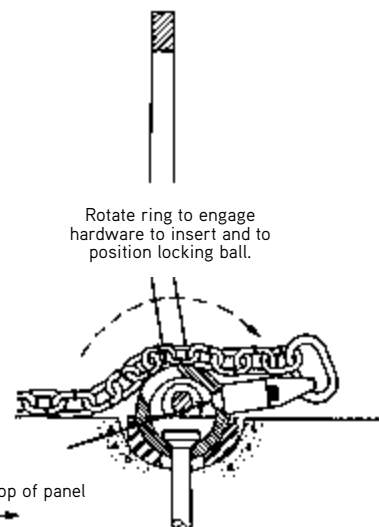
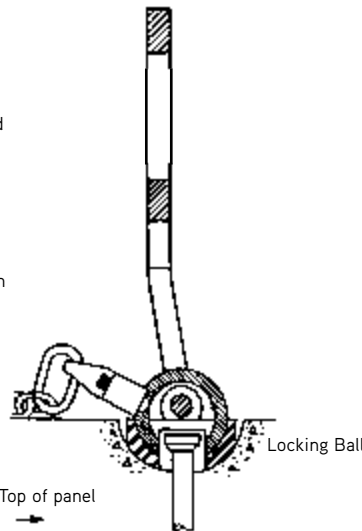





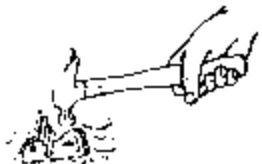

Hardware Installation — After proper concrete cure, the T50 Gyro Tilt Plus Hardware is attached to the crane rigging and moved to the panel to be lifted. The plastic void cap is removed from the insert assembly and the void checked for foreign matter. The hardware is placed in the void in the "open" position that allows the hardware to nest over the head of the insert. Moving the hardware ring to the "closed" position captures the head of the insert and allows the lifting sequence to begin. Visual inspection will confirm proper hardware installation.

Stripping — After the panel has been lifted, placed and properly braced, the Gyro Tilt Plus Hardware is released by slackening the crane line and a simple, solid pull on the ground release lanyard. With the hardware released, the crane may move to the next panel and repeat the sequence.

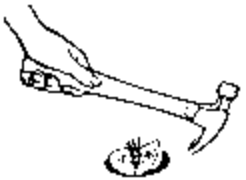
Warning! The crane line and bail of the lifting hardware must be turned in the direction of the cable forces before the lifting operation begins. The crane line must not be allowed to apply a sideward force on the bail, as this condition is dangerous and could lead to premature failure of the hardware or insert.

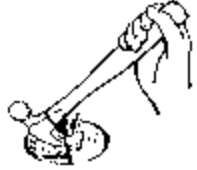
How to Remove the Gyro Tilt Plus Plastic Recess Plug

 <p>1. The Gyro Tilt Plus Insert's location in the panel is easily found by locating the antennae which will project through the surface of the concrete.</p>	 <p>2. Using an ordinary claw hammer, tap lightly around the antennae, breaking through the thin skin of concrete to expose the insert. Avoid striking the concrete too hard to avoid breaking through the plastic recess plug.</p>	 <p>3. Drive the claws of the hammer down about 3/8" between the end of the recess plug and the concrete.</p>
 <p>4. Pry up on the end of the recess plug until one half of it "pops up" to a point where it is about one third of the way out of the concrete. For the time being, leave it as it is and proceed with step #5.</p>	 <p>5. Repeat steps #3 and #4 to loosen the opposite half of the recess plug.</p>	 <p>6. Grasp both halves of the recess plug between the thumb and finger and squeeze.</p>
 <p>7. Both halves of the recess plug should now be easily removed, exposing the insert.</p>	 <p>8. If one half of the recess plug is hard to remove, drive the claws of the hammer as deeply as possible between the recess plug and the top of the insert. Push forward on the hammer with one quick motion to remove the recess plug.</p>	 <p>9. Remove all debris from around the insert and the recess plug. The insert is now ready to receive the lifting hardware.</p>

Gyro Tilt™ Plus System

Proper Hardware Usage

Prior to lifting any tilt-up panel, apply an initial load to the crane lines, making certain that the hardware is properly attached to the head of the T49 Gyro Tilt Plus Insert and that the bail of the lifting hardware is aligned with the crane line.

Warning! Do not apply a sideward load to the bail of the lifting hardware.

Warning! Do not modify, weld or alter in any way Gyro Tilt Plus Hardware units. Such actions could lead to premature failure of the hardware.

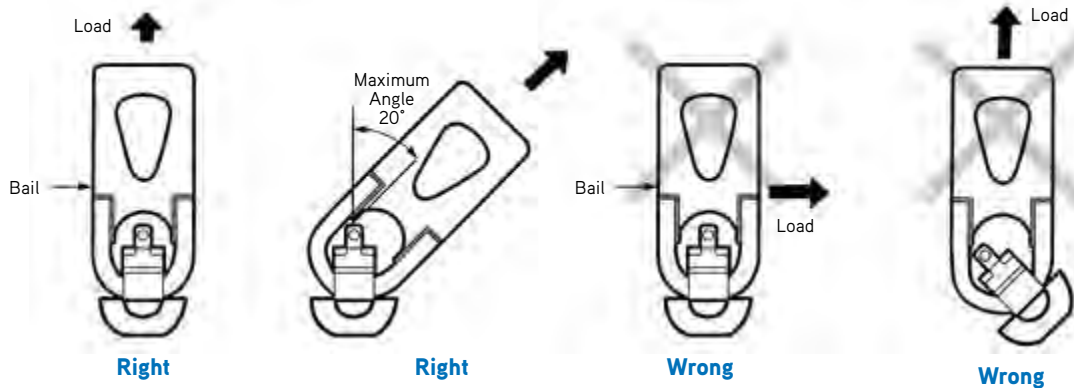

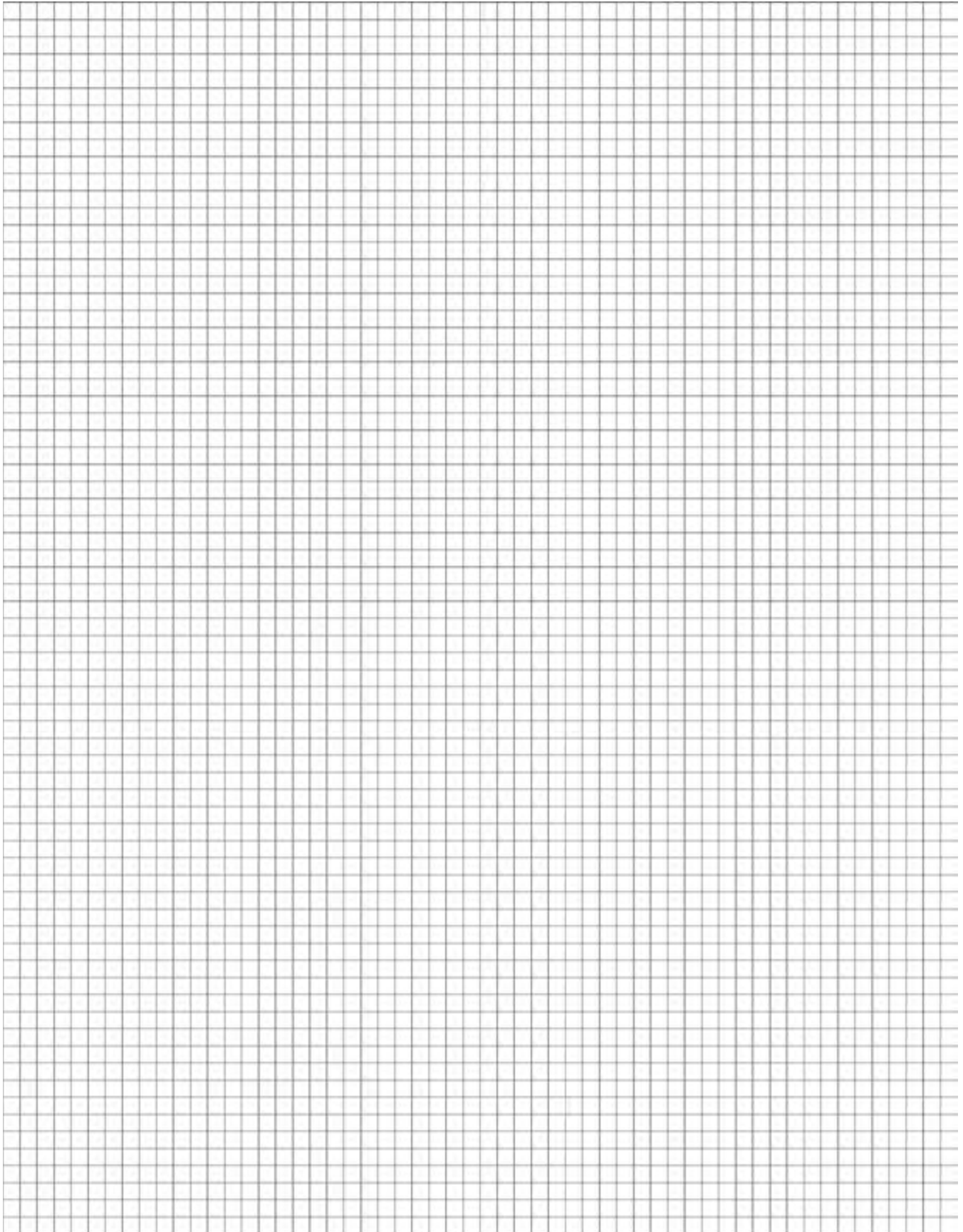

T1 Single Pick-Up Insert

- Available with plastic tipped feet or stainless steel tips
- Available with insert locator plug installed
- Uses standard coil threaded bolts
- Uses T12 or T26 lifting plate
- Insert provides 3/8" setback from panel face
- Recommended minimum edge distance is 15"
- For proper bolt length see "How to Determine Bolt Lengths" in this section
- Only the 1-1/4" and 1-1/2" diameter inserts are recommended for use as pick-up inserts. The 1" diameter inserts are used for attachment of strong backs to a panel while the 3/4" diameter is used as a brace anchor.

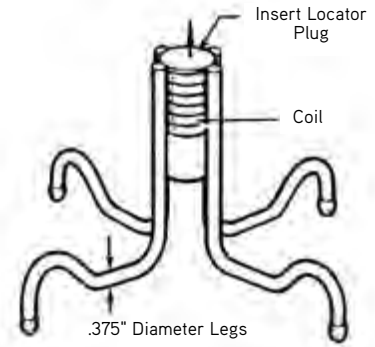

Coil Bolt Diameter	Panel Thickness and Safe Working Load per Insert (lbs.)						
	4"	5"	5-1/2"	6"	7"	8"	10"
3/4"	3,400	5,600	6,700	7,800	10,200	11,600	13,500
1"	3,750	6,200	7,500	8,800	11,400	11,400	18,000
1-1/4"	4,200	7,000	8,400	10,200	12,000	12,000	18,000
1-1/2"	4,700	7,800	9,400	11,200	12,500	12,500	18,000

Notes:

1. SWL provides a safety factor of approximately 2 to 1 in 2,500 psi Normal Weight Concrete
2. Corner or edge distances less than 1.5 times the embedment depth will proportionally reduce these ACI 318, Chapter 17 concrete limited capacities.

DANGER! DO NOT use as an edge lifting insert, as insert is not designed for such use.

See "Safe Working Load Reduction Factors for Lightweight Concrete" in the General and Technical Information section.

To Order:

Specify: (1) quantity, (2) type, (3) diameter of bolt to be used, (4) panel a thickness and insert heights, (5) with or without Insert Locator Plug, (6) plastic coated feet or stainless steel tips.

Example:

300 pcs., T1 Single Pick-Up Insert, 1-1/2" diameter for 7-1/2" slab, 7-1/8" insert height with insert Locator Plugs, and plastic coated feet.

Coil Inserts

T21 Insert Locator Plugs

- The T21 plastic setting plugs may be ordered already installed in free standing inserts such as the T1 and be ready for concrete placement to save time.
- Bottom portion of plug has a large barrel shape which allows the B14 coil bolt to penetrate into the void.
- Made of flexible but durable plastic, the top portion is removed from the coil insert by prying it out with a screwdriver.
- The locator tip projects above the surface of the concrete; it bends without breaking off during screeding, and returns to its original position once the screed has passed over.
- The distinctive bright color of the plug makes it easy to locate inserts in the slab.
- The coil bolt used to attach lifting, bracing or other hardware will crush the bottom half of the plug as it is screwed into the insert, and normal penetration beyond the end of the coil will be achieved with ease.

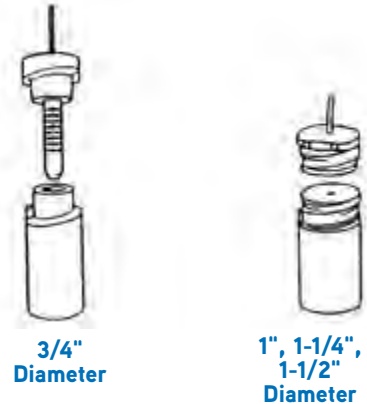

To Order:

Specify: (1) quantity, (2) type, (3) diameter.

Example:

100 sets T21 Insert Locator Plugs, 1-1/4" diameter.

T2 Double Pick-Up Insert

- Available to fit 1" or 1-1/2" diameter coil bolts.
- Available with plastic tipped feet or stainless steel tipped feet.
- Available with insert locator plugs installed.
- Designed for use with T8 lifting angle.
- Insert is setback 3/8" from panel face.
- For proper bolt length, see "How To Determine Bolt Length" in this section.

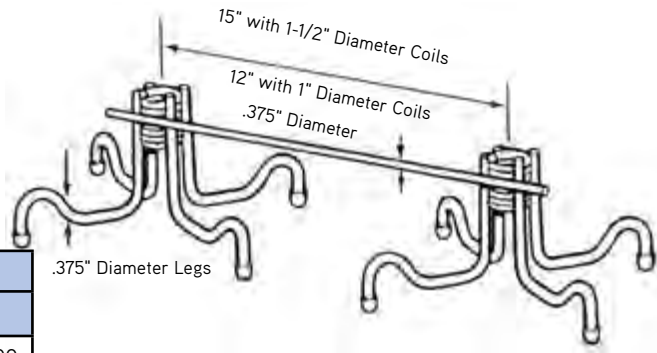

Panel Thickness and Safe Working Load per Insert (lbs.)						
Coil Diameter	4"	5"	5-1/2"	6"	7"	8"
1"	5,400	8,100	9,400	10,800	13,500	16,000
1-1/2"	---	---	---	12,600	15,000	18,000

Safe working load provides a safety factor of approximately 2 to 1 in 2,500 psi concrete.

DANGER! DO NOT use as an edge lifting insert, as insert is not designed for such use.

See "Safe Working Load Reduction factors for Lightweight Concrete" in General and Technical Information section for lightweight concrete SWL reduction factors.

Insert Placement

Danger! All T2 Inserts must be positioned with the two coils in a horizontal line. If not placed in a horizontal line, the shear loading (when the panel is raised to a vertical position) may be concentrated on one bolt only and severe strain will occur at the cable clevis and the lifting angle gusset.

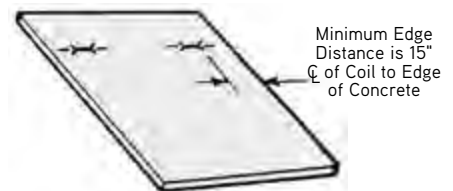
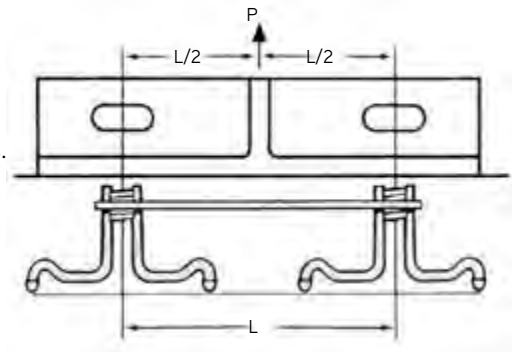

Minimum Edge Distance is 15" ϕ of Coil to Edge of Concrete

To Order:

- Specify: (1) quantity, (2) type, (3) diameter of bolt to be used, (4) panel thickness and insert heights, (5) with or without Insert Locator Plug, (6) plastic coated feet or stainless steel tips.

Example:

250 pcs, T2 Double Pick-Up Insert, 1" diameter for 5-1/2" slab 5-1/8" insert height with insert Locator Plugs and plastic coated feet.

T7S, T7ST Slotted Setting Plugs

- Made of steel
- Used with standard coil threaded inserts to provide void for B14 coil bolts
- Top is cut off square so screed can pass over, also slotted to accept screwdriver
- Threads and slot should be coated with non-staining lubricant to prevent bonding
- Loosen studs within 8-24 hours for easier removal when ready to lift
- Standard sizes are 3/4", 1", 1-1/2" and 1-1/4" diameter x 4" length. Special lengths available.

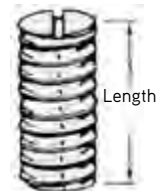

To Order:

Specify: (1) quantity, (2) type, (3) diameter.

Example:

100 sets T7S Slotted Setting Plugs, 1-1/4" diameter.

Exposed Aggregate Details

Exposed Aggregate Face Down

For exposed aggregate panels cast **face down**, the height of the coil insert should be $\frac{3}{8}$ " less than the structural panel thickness. If inserts are ordered based upon overall panel thickness, they will be too high when placed on aggregate.

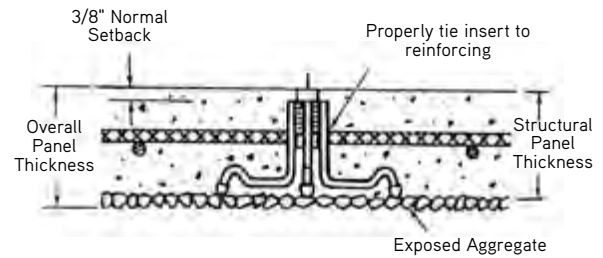

Exposed Aggregate Face Up

For exposed aggregate panels cast **face up**, the height of the coil insert should be the same as the structural panel thickness and not protrude up into the exposed aggregate.

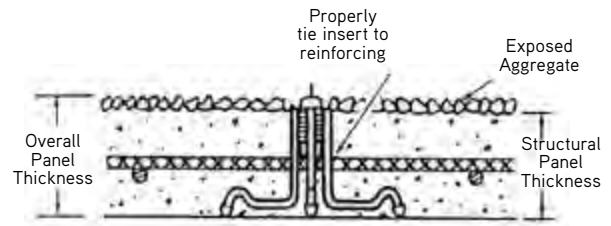







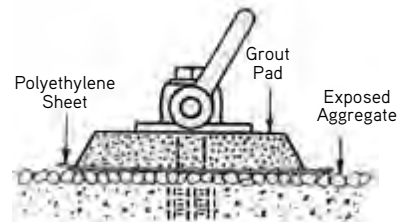
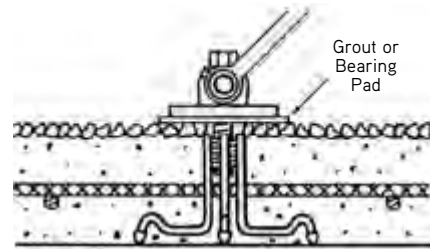

Lifting Exposed Aggregate Face Up

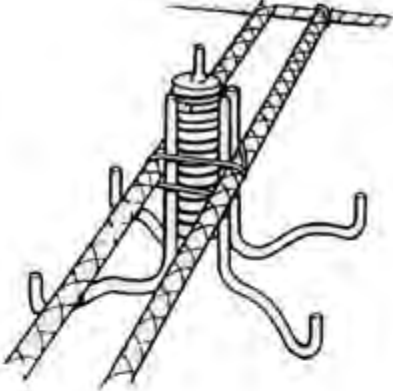
When lifting exposed aggregate panels cast **face up**, if aggregate is carefully tamped and leveled during aggregate placing, it may not be necessary to place a grout or bearing pad under the lifting plate. If aggregate surface is uneven, a bearing pad is recommended under the lifting plate.

When used with large exposed aggregate face up panels, a grout pad is required to provide a bearing surface for the plate. Longer length bolts will be required for these panels. See "Coils" through "B14 Coil Bolts and Minimum Coil Penetration Information" in this section, and the illustration below for determining overall length of required bolts.



How to use Coil Face Inserts

 <p>1. Position insert in place and wire securely to rebar. Make sure coil is perpendicular to panel face.</p>	 <p>2. Place concrete, vibrate carefully in region of insert, and use screeding techniques which prevent crowns in slab. Excessive slab thicknesses increase setback dimensions and require the use of longer bolts.</p>	 <p>3. After plastic plug has been located, chip concrete cover off and with a pair of pliers pull the plug out of the coil.</p> <p>4. Remove T21 Plastic plug by prying it out with a screwdriver</p>
 <p>5. Hole should be small and concise, and if not used immediately, should be plugged to prevent debris and water from entering.</p>	 <p>6. Clean hole, then place lift plate directly over insert hole.</p>	 <p>7. Slip bolt through the hole in the lift plate and start bolt into coil by hand.</p>
 <p>8. Turn bolt clockwise with a wrench until bolt is secured tight against lift plate.</p>	 <p>9. Attach crane line (use double clevises or swivels to take out twists in crane line) to lifting bail. Apply initial tension to crane lines and make sure bail is aligned in the direction of applied loading.</p>	 <p>10. To remove lift plate after panel is erected and secured, turn bolt counter clockwise with a wrench until bolt is free.</p>

Danger! Crane line loads and bail of double-swivel lift plate must be turned in direction of crane forces before lifting operation begins. Crane line loads must not be allowed to apply sideways loads to bail as this condition is dangerous and could lead to premature failure of hardware.

Edge Pick-up

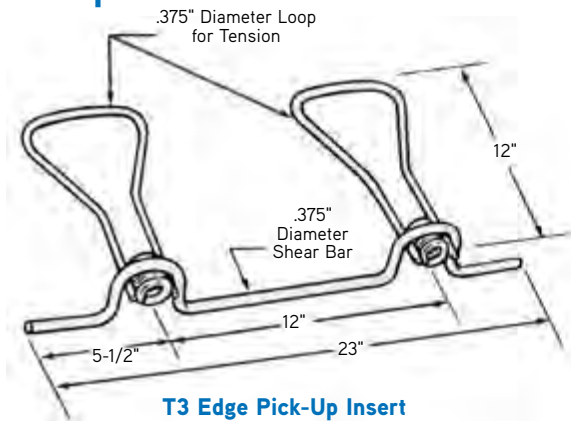

T3 Edge Pick-Up Insert

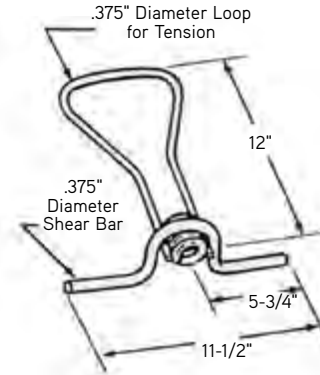

T3A Edge Pick-Up Insert

Safe Working Load Per Insert Thickness (lbs.)

Insert Type	Coil Bolt Dia.	Concrete Strength	Load Condition	4\" Panel	5\" Panel	5-1/2\" Panel	6\" Panel	6-1/2\" Panel	7\" Panel	7-1/2\" Panel	8\" Panel
T3A	1\" Single	2,500	Tension	—	6,000	6,600	7,200	7,800	8,400	9,000	9,000
			Shear	—	2,700	2,750	2,800	2,850	2,900	3,000	3,100
T3	3/4\" Double	2,500	Tension	5,000	—	—	—	—	—	—	—
			Shear	3,000	—	—	—	—	—	—	—
T3	1\" Double	2,500	Tension	—	8,000	8,800	9,600	10,400	11,200	12,000	12,800
			Shear	—	4,200	4,500	4,800	5,100	5,400	5,700	6,000

Approximate safety factor 2 to 1 in normal weight concrete. SWL's are based on the insert set back 1/2\" from face of concrete.

Warning! See "Safe Working Load Reduction factors for Lightweight Concrete" in General and Technical Information section for lightweight concrete SWL reduction factors.

Proper Placement of "Edge" T3 or T3A Inserts

When using EDGE inserts, a 1/2\" thick wood washer or cut washers must be used against the ends of the loops when bolting the insert in place prior to placing concrete. This is necessary so that when the lifting plate is drawn down tightly it will bear against the concrete and not against the loop ends. This procedure is necessary to develop the rated loads shown in the table. EDGE inserts must be located in the center of the panel's structural thickness.

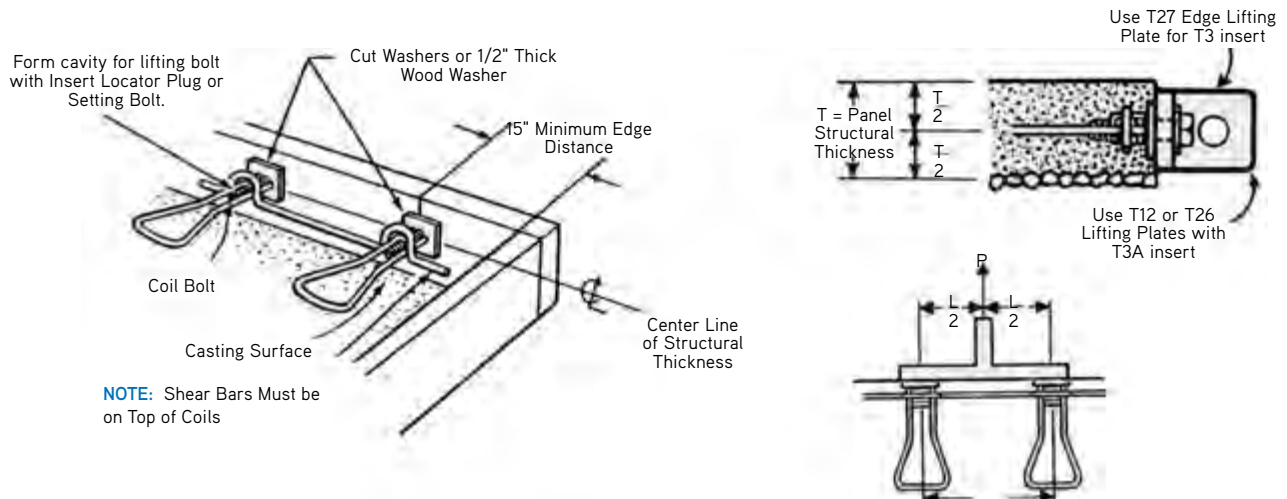

NOTE: Shear Bars Must be on Top of Coils

To Achieve SWL, Lifting Plate must be centered on T3 insert

Total System and Safe Working Loads

The user must be aware of the capacity of the total lifting system since the determination of the safe working load involves concrete strength and safe working loads of the insert, bolt and lifting hardware. All must be evaluated with the governing safe load component and thereby determine the safe working load of the system. This handbook has such values listed in tabular form for all components including the minimum concrete compressive strengths that must exist at time of use. Therefore, do not assume that an insert's safe working load is that of the system, since the SWL's of the bolt or lifting hardware may be less than that of the insert. Examine the values of all components.

Coils

- Standard length coils are available for 3/4", 1", 1-1/4" and 1-1/2" diameter bolts.
- Longer length coils for 1-1/4" or 1-1/2" diameter bolts are used in T1, T24 Single Pick-up Inserts.

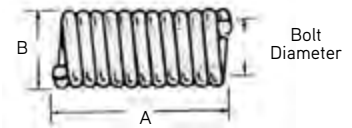

Coil Dimensions

Bolt Diameter	A	B	Wire Diameter	Threads Per Inch
1/2"	1-1/8"	25/32"	.162"	6
3/4"	1-9/16"	1-3/32"	.218"	4-1/2
1"	2"	1-7/16"	.281"	3-1/2
1-1/4"	2"	1-11/16"	.281"	3-1/2
1-1/4"	3-3/16"	1-11/16"	.281"	3-1/2
1-1/2"	2-5/16"	1-15/16"	.281"	3-1/2
1-1/2"	3-7/16"	1-15/16"	.281"	3-1/2

Warning! Do not use coils without strut or leg wires welded to them as they will not develop sufficient load carrying capabilities.

How to Determine Bolt Length

Note! Always check to make certain that you have the proper clearance void to prevent the Lifting Bolt from bottoming out. You must be able to tighten the bolt down tight to prevent the lifting hardware from slipping and applying unexpected loads to the insert.

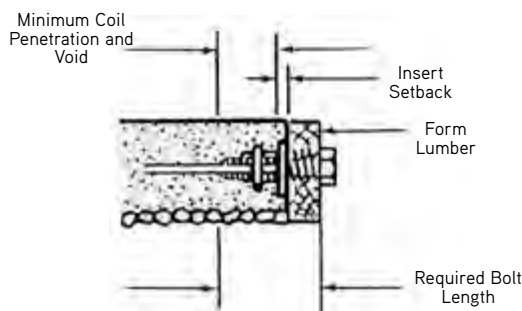

Setting Bolt

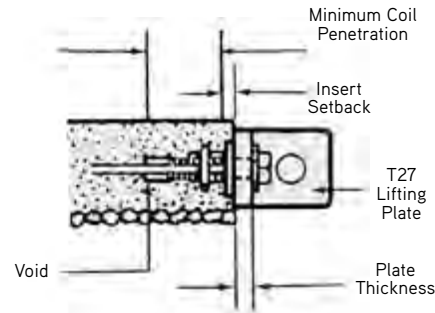

Lifting Bolt

Setting Bolt for Edge Inserts		Lifting Bolt for Edge Inserts	
Form Lumber	1-1/2"	T27 Plate Thickness	1"
Insert Setback	1/2"	Insert Setback	1/2"
Minimum Coil Penetration	2-1/2"	Minimum Coil Penetration	2-1/2"
Minimum Void	1/2"	Total Bolt Length	4"
Total Bolt Length	5"		

Note! Face insert lifting bolt lengths are calculated in a similar manner to that shown above.

B14 Coil Bolts and Minimum Coil Penetration Information

- B14 Coil Bolts have fast-acting, self-cleaning threads and are available in 3/4", 1", 1-1/4" and 1-1/2" diameter bolts.
- Bolts are furnished with integrally formed heads.
- May be reused — but will wear and must be regularly inspected.
- Must be kept clean and lubricated.
- When determining overall length of lifting bolt, see example on previous page — you must consider:
 1. Height of hardware
 2. Insert Setback
 3. Minimum coil penetration
- Minimum coil penetration shown in the charts below applies to all DSC coil products.

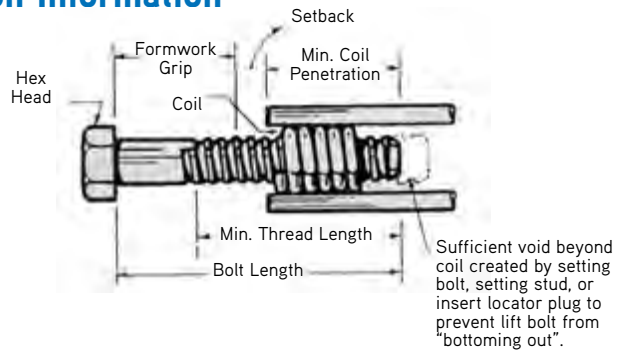

To Order:

Specify:(1) Quantity, (2) Type, (3) Diameter of Bolt, (4) Length of Bolt, (5) Type.

Example:

300 pcs., B14 Coil Bolts, 1" diameter, 5" long with welded on B25 Coil Nut Head.

B14 Coil Bolts High Strength with Integrally Formed Hex Heads

1/2" Diameter Forged Hex Head Safe Working Load		3/4" Diameter Forged Hex Head Safe Working Load		1" Diameter Forged Hex Head Safe Working Load		1-1/4" Diameter Forged Hex Head Safe Working Load		1-1/2" Diameter Forged Hex Head Safe Working Load	
Tension	Shear	Tension	Shear	Tension	Shear	Tension	Shear	Tension	Shear
3,600 lbs.	2,400 lbs.	8,000 lbs.	5,300 lbs.	14,500 lbs.	9,600 lbs.	20,300 lbs.	13,500 lbs.	29,500 lbs.	19,600 lbs.
Minimum Coil Penetration 2"		Minimum Coil Penetration 2-1/4"		Minimum Coil Penetration 2-1/2"		Minimum Coil Penetration 2-1/2"		Minimum Coil Penetration 3"	
Bolt Length	Minimum Thread Length	Bolt Length	Minimum Thread Length	Bolt Length	Minimum Thread Length	Bolt Length	Minimum Thread Length	Bolt Length	Minimum Thread Length
3"	2-1/4"	3"	2-3/4"	3"	2-3/4"	3"	2-3/4"	—	—
4"	3-1/4"	4"	3-3/4"	4"	3-3/4"	4"	3-3/4"	4"	3-3/4"
5"	4-1/4"	5"	4-3/4"	5"	4-3/4"	5"	4-3/4"	5"	4-3/4"
6"	5"	6"	5-3/4"	6"	5-3/4"	6"	5-3/4"	6"	5-3/4"
Over 6"	5"	Over 6"	5-3/4"	Over 6"	5-3/4"	Over 6"	5-3/4"	Over 6"	5-3/4"

Safe Working Load provides a factor of safety of approximately 5 to 1.

Coil Inserts

T8 Lifting Angle

- Designed for use with T2 Double Pick-Up Inserts.
- Shorter bolts are required than those used with swivel lifting plates, normally 4" lengths.
- May be used for face lifting inserts and also edge lifting inserts when panel thickness exceeds 6".
- Cut washers are required under head of all bolts.
- Made from structural steel angle 6" x 6" x 3/4" x 21" long with 1-1/2" dia. hole for clevis attachment.
- Safe working load is 18,000 lbs. with a factor of safety of 5:1.

To Order:
T8 or T27: (1) Quantity, (2) Type, (3) Size

Example:
8 pcs., T8 Lifting Angles.

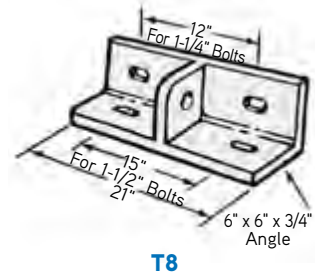

T8

T12 Swivel Lift Plate

- Designed for use with single pick-up inserts.
- Can be used for face lifting or edge lifting
- Available for use with 3/4" or 1" diameter bolts.
- Complete unit made of forged steel.
- Safe working loads: 3/4" diameter is 7,200 lbs. and 1" diameter is 10,000 lbs.

To Order:
T12 or T26: (1) Quantity, (2) Type, (3) Size

Example:
24 pcs., T26 Double Swivel Lifting Plate for 1-1/4" bolts.

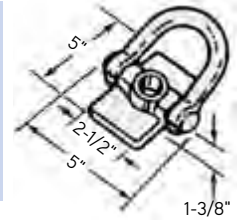

T12

Type	Bolt Size	Loop Height	Bearing Plate
T12	3/4" Diameter	3.688"	1/2 x 2-1/2 x 5"
	1" Diameter	3.688"	1/2 x 2-1/2 x 5"
	1" Diameter	6.75"	1/2 x 2-1/2 x 5"

SWL provides a factor of safety of approximately 5 to 1.

T26 Double Swivel Lifting Plate

- Designed for use with 1", 1-1/4" and 1-1/2" diameter coil bolts.
- Rotates 360 degrees in horizontal plane and 180 degrees in vertical plane.
- Round bearing plate provides maximum safety when used with any coil bolt lifting system.
- Heavy forged bail is made of high-strength material.
- Double swivel action allows bail to rotate in direction of applied load.
- Safe working load is 9,000 lbs. for 1" diameter.
- Safe working load is 13,500 for 1-1/4" and 1-1/2" diameter.

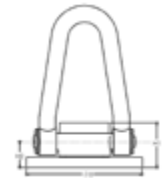

T26

Type	Bolt Size	H	D
T26	1" Diameter	2-11/16"	5"
T26	1-1/4" or 1-1/2" Diameter	2-3/4"	7"

SWL provides a factor of safety of approximately 5 to 1.

T27 Edge Lifting Plate

- Designed for use with T3 or T11 pick-up inserts.
- Made from structural steel plate 1" x 4" x 18" long.
- Cut washers are required under head of all bolts.
- For use with 3/4" or 1" dia.inserts.
- For panels 6" thick or more, use T8.
- Safe working load is 8,800 lbs. with a factor of safety of 5:1.

Warning! Never use T27 with face inserts.

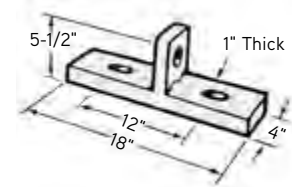

T27

Safety Notes

- All plates must have full bearing on flat, smooth surfaces
- Lifting angle and plates must not be used without a bolt fastener of sufficient strength to develop the required loads.
- Lifting angle and plates are to be used only with the bolt diameter for which they were designed. For example, use a 3/4" bolt with a 3/4" Swivel Lifting Plate, do not use a 3/4" bolt with a 1", 1-1/4" or 1-1/2" T12 Swivel Lifting Plate
- All plates must be securely fastened to the concrete panels.
- For exposed aggregate panels, a grout pad is required for the bearing plate
- Coil bolt penetration must agree with minimums.

Danger! Crane line loads and bails of swivel and double swivel lifting plates must be turned in direction of crane forces before lifting operations begin. Crane line loads must not be allowed to apply sideward loads to bails of Swivel Lifting Plates or Clevis Attachment Plates of Lifting Angles or Lifting Plates, as this condition is dangerous and could lead to failure of hardware.

Continuous Coil Threaded Rod

- Available in 3/4", 1", 1-1/4" and 1-1/2" diameters.
- Available in high tensile strengths.
- May be cut with carborundum blades without damaging the threads.
- Do not use cutting torch to cut coil rod to length.
- Used with B13 or B25 Coil Nuts for making special Coil Bolts.
- B12 requires two B13 or one B25 Coil Nut in order to develop safe working loads.
- B12 standard length is 12'-0" — available in any length up to 20'-0" on special order.

Coil Rod Diameter	B12 High Tensile Designation	Safe Working Load	
		Tension	Shear
3/4"	24M	7,200	4,800
1"	50M	15,000	10,000
1-1/4"	75M	22,500	15,000
1-1/2"	90M	27,000	18,000

To Order:

Specify: (1) quantity, (2) type, (3) diameter, (4) length.

Example:

500 pcs. 24M, B12 High Tensile, 1" dia. for 8-1/2" long.



Approximate safety factor of 5 to 1 for tilt-up hardware.

B13 Coil Nut and B25 Heavy Nut

- B13 Coil Nut is made with 3/4", 1", 1-1/4" or 1-1/2" Diameter Coil Threads
- B25 Heavy Coil Nut is made with 3/4" or 1" Diameter Coil Threads

B13 and B25 Coil Nut Selection Chart					
Coil Nut Type	Dia.	Approx. Height	"A" Width Across Flats	Safe Working Load Tension (lbs.)	
				Using One B13 Nut	Using Two B13 Nuts or One B25 Heavy Nut
B13	3/4"	5/8"	1-1/8"	3,600	7,200
B25	3/4"	1-3/16"	1-1/8"	—	7,200
B13	1"	1"	1-5/8"	7,200	15,000
B25	1"	2"	1-3/8"	—	15,000
B13	1-1/4"	1-1/4"	2"	10,800	22,500
B13	1-1/2"	1-1/2"	2-3/8"	16,200	27,000

SWL provides a factor of safety of approximately 5 to 1, for tilt-up hardware.

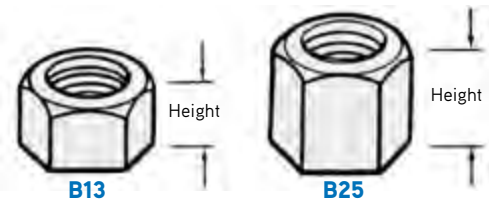

To Order:

Specify: (1) quantity, (2) type, (3) bolt dia.

Example:

200 pcs. B13 Coil Nut, 3/4" diameter.

B11 Flat Washer

- For use with all types and sizes of bolts and coil rod.
- Made from carbon steel.
- Sizes shown will effectively transfer loads to wooden strongbacks.
- Maximum space between strongbacks should not exceed bolt diameter, plus 1/4".

Type	Bolt Diameter	Safe Working Load	Sizes
B11 Standard	1/2"	2,250 lbs.	3" x 4" x 1/4"
B11 Heavy	1/2"	3,375 lbs.	4" x 5" x 1/4"
B11 Standard	3/4"	3,375 lbs.	4" x 5" x 3/8"
B11 Heavy	3/4"	9,000 lbs.	5" x 5" x 3/8"
B11 Standard	1"	9,000 lbs.	5" x 5" x 1/2"
B11 Heavy	1"	18,750 lbs.	7" x 7" x 3/4"
B11 Standard	1 - 1/4"	12,000 lbs.	5" x 5" x 5/8"
B11 Heavy	1 - 1/4"	18,750 lbs.	7" x 7" x 3/4"
B11 Standard	1 - 1/2"	18,750 lbs.	5" x 5" x 3/4"
B11 Heavy	1 - 1/2"	18,750 lbs.	7" x 7" x 3/4"

SWL provides a factor of safety of approximately 5 to 1, for tilt-up hardware.

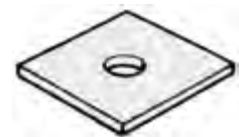

B11 Flat Washer

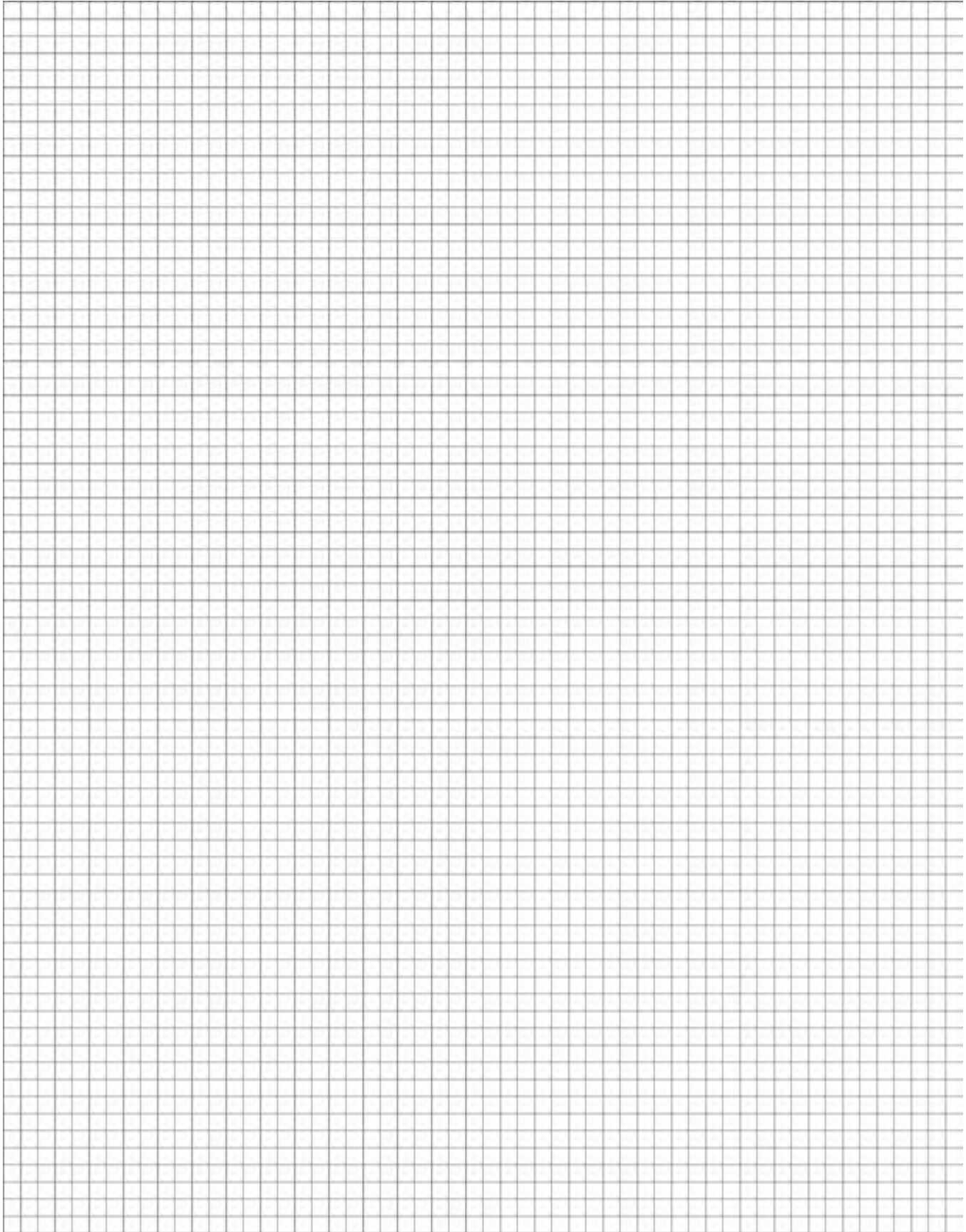

Strongbacks

When openings are required in a tilt-up panel, they often create greater bending stresses in the remaining concrete sections. If additional reinforcing steel is not an option or practical, strongbacks can be used effectively to stiffen the panel. Strongbacks may be fabricated from lumber, aluminum or steel and are usually reusable. DSC Engineers design using Steel Strongbacks. Designs using other types of material may be requested by the customer, but will require additional information.

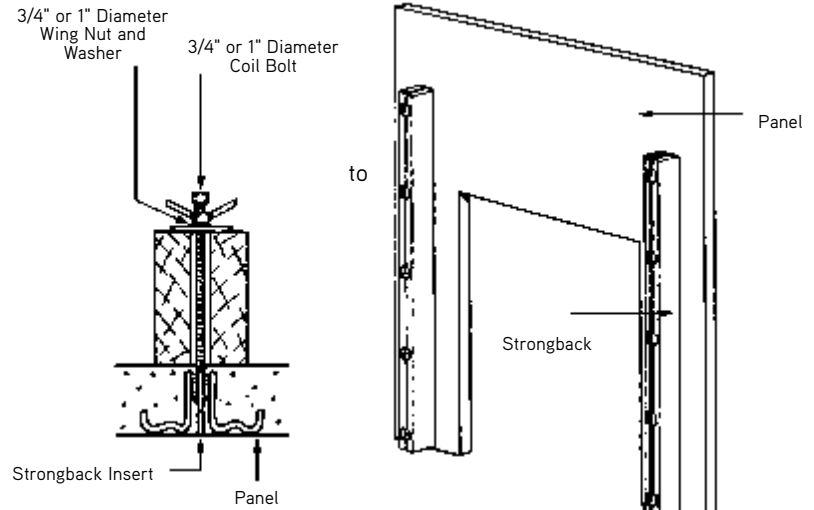

Section Through Strongback

Strongback Stiffened Tilt-Up Panel

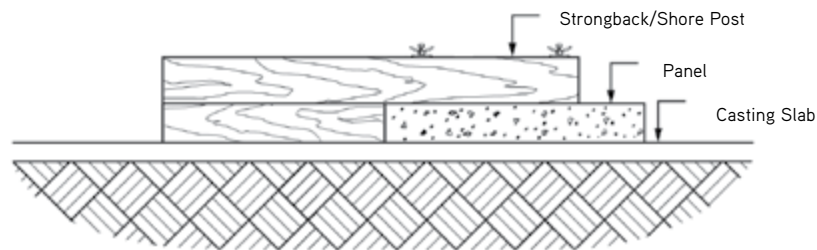

Strongback/Shore Post

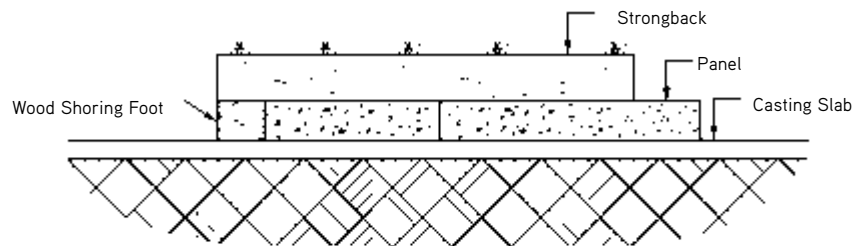

Strongback With Foot

Strongback-Shore/Blocking

The strongback-shore system is used to reduce stresses during the lifting process and stabilize the panel during and after erection. Generally, this system should be utilized on panels where an offset opening is equal to or greater than 1/2 the panel width. The concrete leg section must be checked for stresses to determine if additional reinforcing steel or strongbacks are needed.

Strongback size should be of sufficient width and depth to carry erection loads and consist of material strong enough to withstand repeated use. The shore depth should be the same nominal size as the panel thickness, i.e., a 6" panel would require a 4x6 or 6x6 shore.

The shoring/blocking must be adequate to support the wall's weight when in place at its full vertical position. This blocking is design and specified by the Field Engineer, based on the vertical loads and shoring material.

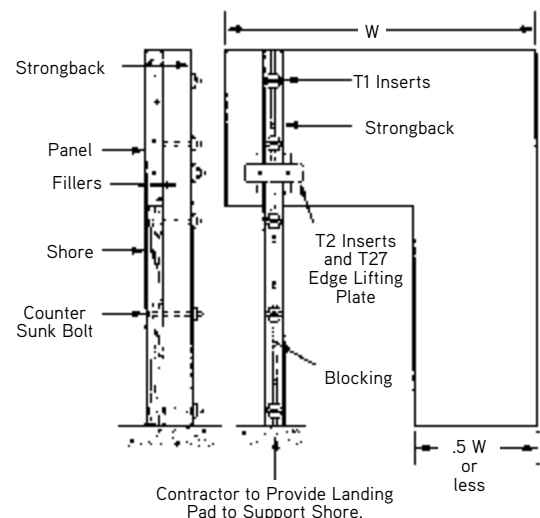

Strongback System

Strongbacks

When strongbacks are specified, they must be of the proper number, size and located as shown on the Panel Layout Sheet. Strongbacks, depending on type specified, must meet the following requirements:

- Aluminum strongbacks must be Dayton Superior T63 Aluminum Strongbacks.
- Symons Soldier Beam
- Steel strongbacks must meet ASTM Standard A36.

Bolts used to attach strongbacks must be securely tightened to resist movement of the strongbacks during the erection process.

Maximum space between strongbacks is the bolt diameter plus 1/2".

Strongbacks Using Coil Inserts, Coil Bolts and Flat Washers

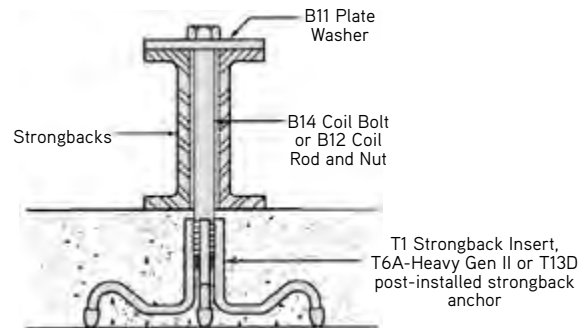

Single Strongback Insert and Bolt

T63 Aluminum Strongback Beams

The Dayton Superior T63 Aluminum Strongback beams are heavy aluminum channels available in 10 ft., 15 ft., 20 ft., and 25 ft. lengths for use as strongbacks for concrete tilt-up panels. T63 beams are furnished in sets of two channels each.

NOTE: All product located on the West Coast only.

To Order:

Specify: (1) quantity, (2) name, (3) length.

Example:

12 sets, T63 Aluminum Strongback Beams, 20' long.

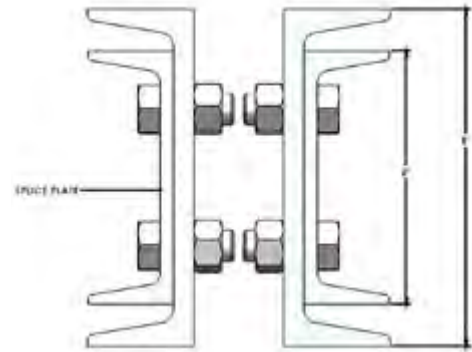

T63S Splice Plate for T63 Beams

The Dayton Superior T63S Splice Plate is available for splicing T63 beams to extend their effective strongbacking length.

To Order:

Specify: (1) quantity, (2) name.

Example:

6 sets, T63S Splice Plates.



Strongback System

Strongback Assemblies

T63 Aluminum Strongbacks are available in stock lengths of 10 ft., 15 ft., 20 ft., and 25 ft. However, by using the T63S Aluminum Splice Plate Assembly to splice together various combinations of stock length strongbacks, you can also make up 30 ft., 35 ft., 40 ft., 45 ft. and 50 ft. lengths.

Some methods of attaining the various lengths of strongbacks are illustrated below.

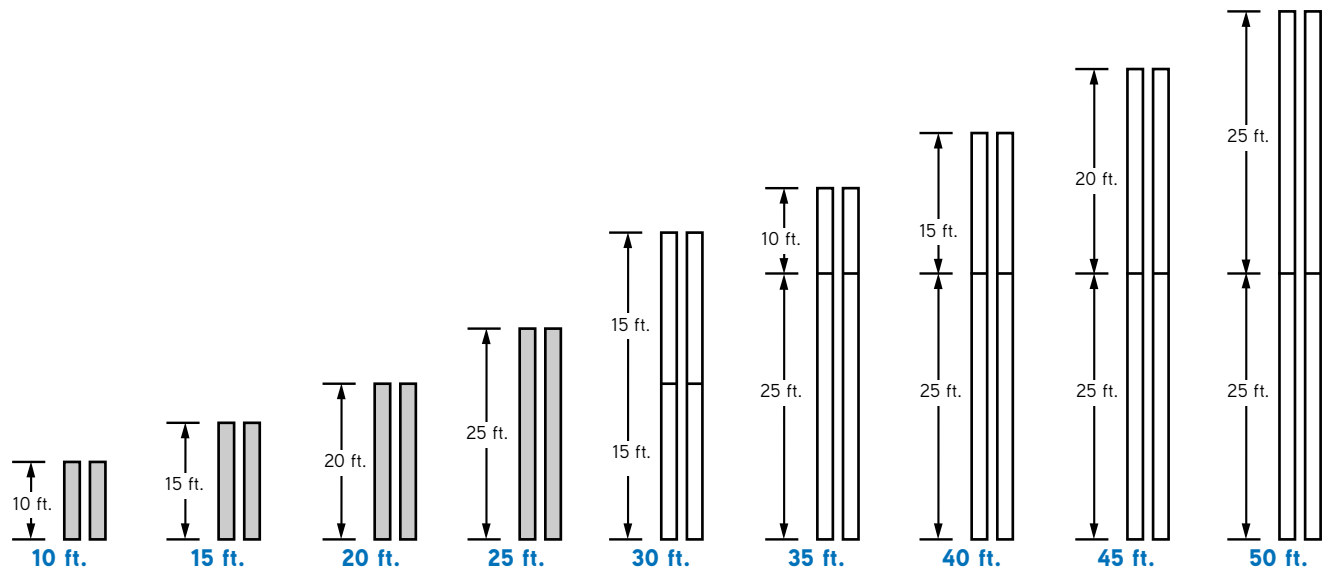

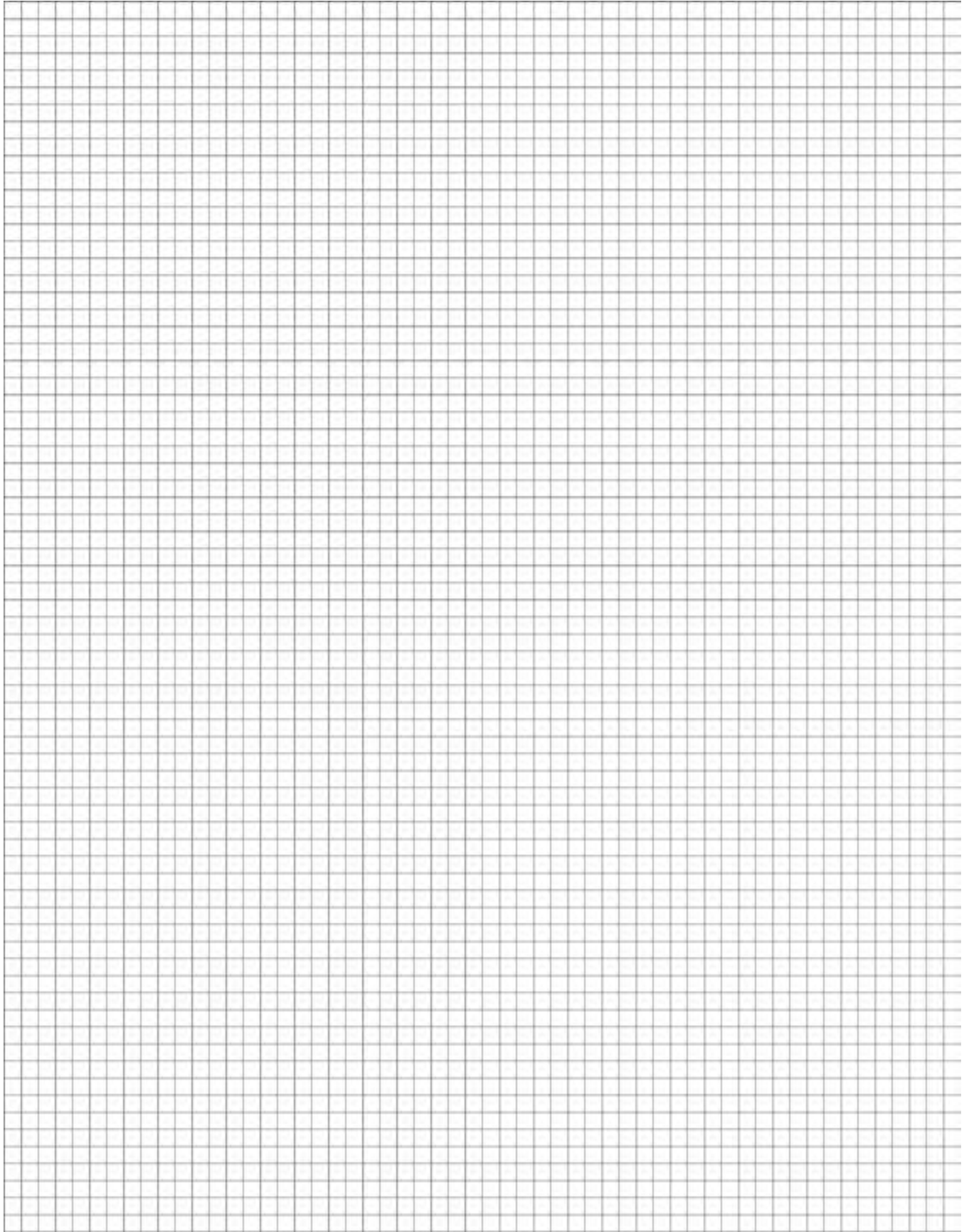

Brace Wind Loading

Bracing recommendations shown in these instructions are for the sole purpose of temporarily bracing full erected tilt-up panels against wind loads only. Dayton Superior adheres to the wind loading provisions defined in the latest edition of the Tilt-Up Concrete Association's Guideline for Temporary Wind Bracing (TCA 18.1).

Braces and brace anchors are not designed or intended to sustain impact loads. Precautions must be taken to arrange the panel erection sequence so as to avoid the potential for impacting upright panels or portions of the bracing system. Bracing recommendations for other loads or forces that might be applied to the bracing system are beyond the scope of Dayton Superior. For bracing recommendations other than wind loads, the user should engage a design agency with capabilities of performing such a service.

Please contact Dayton Superior's Technical Services with any questions regarding the temporary wind bracing requirements for your project.

Warning: If wind loads of 35 mph occur, an inspection of all brace connections should be made. Loose connections can cause panels to fall. If local codes require a higher construction period design wind speed, contact Dayton Superior for additional bracing recommendations.

Brace Removal

This bracing system is designed to temporarily support tilt-up panels against wind loads until the building structure is complete and self supporting. The bracing system should never be disconnected or removed until the panels are secured by the permanent structural connections and all lateral load resisting systems are securely in place, per the Engineer of Record's specifications.

If the structural documents do not indicate when the temporary bracing system can be removed, the engineer of record should be consulted.

Safety Notes:

- Panel should be plumb with braces installed before panels are released from the crane.
- Panels require a minimum of two braces per panel.
- All members of the brace system must be in place and secured at the end of each day.
- Do not erect panels or continue working during excessive windy or adverse weather conditions.
- All brace inserts should be a minimum of 12" from any panel edge, opening, control joint or construction joint.
- Panel bracing is designed to withstand specified wind loads until panels are connected to the structural system of the building. Do not remove any members of the bracing system until all structural connections are completed.
- Only use the brace type as noted on the Panel Layout Sheet. No substitute brace hardware shall be used and all braces must be positioned at the specified locations.
- For special bracing conditions that require deviation from the bracing dimensions shown on the Panel Layout Sheet contact Dayton Superior for recommendations.
- See Panel Layout Sheet for type of brace and number of braces per panel.
- Welding or bolting the tilt-up panels in place might preclude the use of braces.
- After winds of 35 mph or more have been experienced at the job site, the tilt-up contractor must check the tightness of the bolts that secure the wall and foot plates to the concrete. Re-tightening of these bolts to the proper torque will assure that the pipe braces are secure.
- The safe working load of the panel's bracing system may be drastically reduced if other types of brace anchors are used other than specified brace anchors notated on panel details.
- Slab design must be reviewed by the engineer of record to ensure the slab is capable of withstanding the loads being applied by the braces.

Brace to Floor Slabs

Dayton Superior specifies the T13 drill-in anchor for use in attaching braces to the floor slab.

Warning! The floor slab sections may not be adequate to safely support the loads applied to the floor slab by the wall braces. It is the contractor's responsibility to ensure if a section of floor slab can safely support the applied brace loads. Dayton Superior cannot make this determination as it has no control over floor slab thickness, control joint spacings, width of the floor slab "leave out" strip or other factors that may affect the load carrying capacity of the floor slab. Movement of a section of floor slab can cause panels to fall, which may result in property damage and/or severe personal injury. The floor slab should be designed by a competent engineer to resist the applied loads. To assist the contractor or engineer, the maximum strength level brace load per panel is shown on each panel detail sheet provided by Dayton Superior.

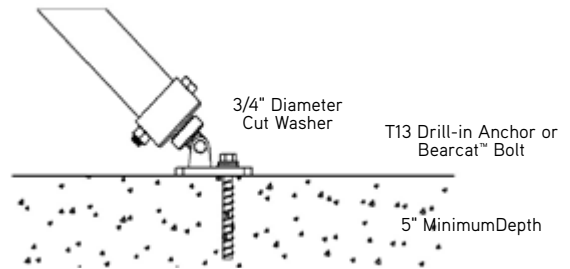

Brace Length and Safe Working Loads

How to Calculate Brace Length

- D = Elevation — top of panel above floor slab (not necessarily same as panel height).
- V = Wall insert dimension
- X = Floor insert dimension
- L = Brace length

The wall insert dimension (V) must be a minimum of 5% above the panel's geometric and mass center of gravity. Additionally, the wall insert dimension, (V), must be at least 60% of the overall panel height. After the locations of the braces are determined, the panel structure should be checked to verify that it is able to resist temporary wind loads.

Brace locations other than those shown may drastically increase brace loads. Brace angles over 60° from the horizontal result in poor mechanical advantage and excessive vertical kick, while brace angles under 45° decrease brace buckling strength due to greater length and excessive sag.

Danger! Bracing must be installed at 90° ± 5° to plane of panel or brace safe working load will be greatly reduced.

The following is a quick "Rule of Thumb" to use in determining if a brace is installed at 90° ± 5° to the panel: The brace may be skewed left or right 1 inch for every 1 foot that the brace anchor is located away from the wall. For example: If your dimension "X" is 15 ft, then your braces may be skewed 15" left or right and still stay within the required 5° tolerance. See panel layout sheets for proper "X" dimension.

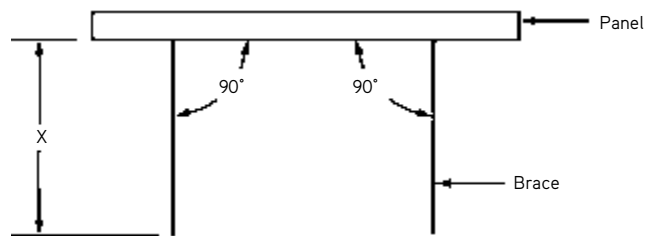
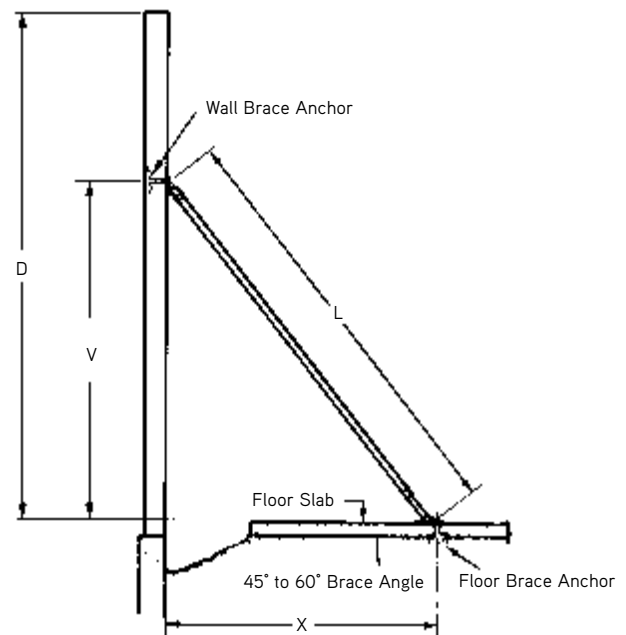

Plan View

Bracing Information

T14 Tilt-Up Wall Braces

The T14 Tilt-Up Wall Braces are all steel, heavy duty wall braces designed to quickly and easily align and brace tilt-up wall panels. Rough adjustment of the T14 braces is easily accomplished by telescoping the pipes to the nearest incremental hole.

Final adjustment is then achieved by simply turning the brace. Dayton Superior wall braces are available in numerous sizes to provide a continuous range of tilt-up panel heights of fifty feet or more. Refer to the table below for additional information.

T14 Tilt-Up Pipe Brace

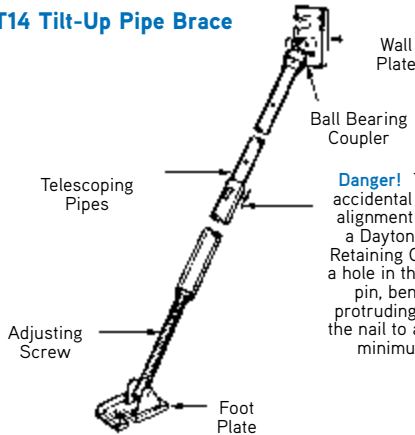

T14 Tilt-Up Jumbo Brace

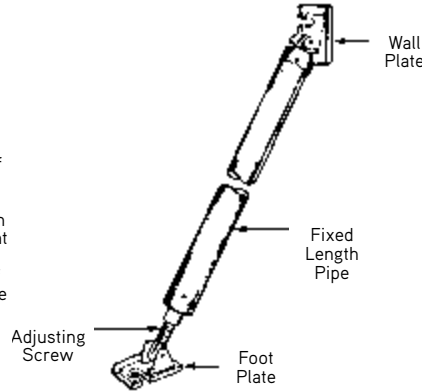

Danger! To prevent accidental removal of alignment pin, insert a Dayton Superior Retaining Clip through a hole in the alignment pin, bending the protruding portion of the nail to a 45 degree minimum angle

To Order:

Specify: (1) quantity, (2) name, (3) model.

Example:

200, T14 Tilt-Up Wall Braces. Model Superior 22.

T14 Pipe Brace Selection Chart

New Name	Old Name	Overall Length	Description	Brace Weight (Lbs)
Superior 5-8	B0	Adjustable - See Description	5'-0" to 8'-0"	60
Superior 8-14	B1A	Adjustable - See Description	8'-0" to 14'-0"	87
Superior 14-23	B4	Adjustable - See Description	14'-6" to 23'-6"	130
Superior 22-30	B5	Adjustable - See Description	22'-6" to 30'-10"	208
Superior 17	B7	17'-0"	17'-0" Fixed Length	107
Superior 22	B8	22'-0"	22'-0" Fixed Length	130
Superior 22+5	B9	27'-0"	22'-0" Fixed Length + 5'-0" Extension Pipe	172
Superior 22+10	B10	32'-0"	22'-0" Fixed Length + 10'-0" Extension Pipe	193
Superior 32	B12A	32'-0"	32'-0" Fixed Length	245
Superior 33 HD	B17S	33'-0"	33'-0" Fixed Length (Large Diameter HD Pipe)	489
Superior 32+5	B16	37'-0"	32'-0" Fixed Length + 5'-0" Extension Pipe	360
Superior 32+10*	B14	42'-0"	32'-0" Fixed Length + 10'-0" Extension Pipe	382
Superior 32+10+10	B15	52'-0"	32'-0" Fixed Length + (2) 10'-0" Extension Pipe	410
Superior 42	B17A	42'-0"	42'-0" Fixed Length	613
Superior 52	B18	52'-0"	52'-0" Fixed Length	984
Superior 62**	B20	62'-0"	52'-0" Fixed Length + 10'-0" Extension Pipe	1,275

Notes: Field assembly is required for Superior 32+10 (B14), Superior 32+10+10 (B15), and Superior 62 (B20) braces. Fixed length allows for +/-9" of adjustment except Superior 42 (B17A) brace has +/-7.5" of adjustment. Pipe Extensions: T15 for the Superior 22 (B8) model and T20 for the Superior 32 (B12) model.

*Ultimate Load based on adequate brace to HGA or slab connection. **Not available for rental.

T15 Pipe Brace Extensions

The Dayton Superior Pipe Brace Extensions are available for the Superior 22 (B8) and Superior 32 (B12A) pipe brace models. The T15 extension for the Superior 22 model extends the brace five feet or ten foot increments. The T20 extension for the Superior 32 model extends the brace in five or 10 foot increments.

To Order:

Specify: (1) quantity, (2) name, (3) model.

Example:

40, T15 Pipe Brace Extension, 5' extension for Superior 22 braces.

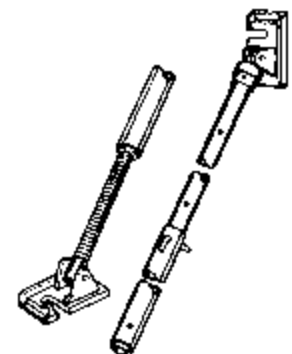

Brace Length and Ultimate Loads

Superior 8-14 Short Pipe Brace				
D	V	X	L	Ultimate Load
9'-0"	6'-0"	4'-6"	7'-6"	9,750 lbs
9'-6"	6'-5"	4'-8"	7'-11"	9,750 lbs
10'-0"	6'-8"	5'-0"	8'-4"	9,750 lbs
10'-6"	7'-0"	5'-3"	8'-9"	9,750 lbs
12'-0"	8'-0"	6'-0"	10'-0"	9,750 lbs
13'-0"	8'-9"	6'-3"	10'-9"	9,675 lbs
14'-0"	9'-6"	6'-9"	11'-8"	7,838 lbs
15'-0"	10'-0"	7'-4"	12'-5"	6,675 lbs
16'-0"	10'-9"	7'-9"	13'-3"	5,625 lbs

Superior 14-23 Heavy Duty Regular Pipe Brace				
D	V	X	L	Ultimate Load
18'-0"	12'-0"	9'-0"	15'-0"	9,750 lbs
19'-0"	12'-8"	9'-6"	15'-10"	9,750 lbs
20'-0"	13'-4"	10'-0"	16'-8"	9,750 lbs
21'-0"	14'-0"	10'-6"	17'-6"	8,888 lbs
22'-0"	14'-8"	11'-0"	18'-4"	7,200 lbs
23'-0"	15'-4"	11'-6"	19'-2"	5,888 lbs
24'-0"	16'-0"	12'-0"	20'-0"	5,363 lbs
25'-0"	16'-8"	12'-6"	20'-10"	4,463 lbs
26'-0"	17'-4"	13'-0"	21'-8"	3,750 lbs
27'-0"	18'-0"	13'-6"	22'-6"	3,413 lbs
28'-0"	18'-8"	14'-0"	23'-4"	2,525 lbs

Superior 22-30 Heavy Duty Long Pipe Brace				
D	V	X	L	Ultimate Load
27'-0"	18'-0"	13'-6"	22'-6"	8,963 lbs
28'-0"	18'-8"	14'-0"	23'-4"	7,988 lbs
29'-0"	19'-4"	14'-6"	24'-2"	7,200 lbs
30'-0"	20'-0"	15'-0"	25'-0"	6,375 lbs
31'-0"	20'-8"	15'-6"	25'-10"	5,175 lbs
32'-0"	21'-4"	16'-0"	26'-8"	4,238 lbs
33'-0"	22'-0"	16'-6"	27'-6"	3,825 lbs
34'-0"	22'-8"	17'-0"	28'-4"	3,150 lbs
35'-0"	23'-4"	17'-6"	29'-2"	2,625 lbs
36'-0"	24'-0"	18'-0"	30'-0"	2,400 lbs
37'-0"	24'-8"	18'-6"	30'-10"	2,025 lbs

T23 Square Braces

Square Braces							
New Brace Name	Former Brace Name	Outside Dim.	Std. Brace Length	Brace Length Min.	Brace Length Max.	Ultimate Load** (Lbs)	Brace Weight* (Lbs)
B21R23S	B21F	4.0"	21'	21'-0"	23'-3"	23,250	230
B27R36S	B27BF	5.0"	27'	25'-7"	27'-3"	36,000	350
B32R24S	B32F	5.0"	32'	30'-9"	33'-3"	24,375	405
B33R22S	B33F	5.0"	33'	31'-9"	34'-3"	22,500	410

Notes:* Does not include weight of connectors.

** Ultimate Load based on adequate brace to HGA or slab connection.

Jumbo Pipe Braces						
New Name	Old Name	D	V	X	L	Ultimate Load
Superior 5-8	B0	8'-0"	6'-4"	4'-10"	5'-8"	10,000 lbs
Superior 17	B7	15'-0" to 24'-0"	13'-6"	10'-4"	17'-0"	13,050 lbs
Superior 22	B8	19'-0" to 31'-0"	17'-6"	13'-4"	22'-0"	9,750 lbs
Superior 22+5	B9	23'-0" to 39'-0"	21'-6"	16'-4"	27'-0"	7,200 lbs
Superior 22+10	B10	27'-0" to 46'-0"	25'-6"	19'-3"	32'-0"	5,400 lbs
Superior 32	B12A	27'-0" to 46'-0"	25'-6"	19'-4"	32'-0"	13,500 lbs
Superior 33 HD	B17S	32'-3" to 33'-6"	26'-4"	19'-11"	33'-0"	25,000 lbs
Superior 32+5	B16	42'-0"	29'-6"	22'-4"	37'-0"	12,000 lbs
Superior 32+10	B14	35'-0" to 60'-0"	33'-6"	25'-4"	42'-0"	7,800 lbs
Superior 32+10+10	B15	43'-0" to 60'-0"	41'-6"	31'-4"	52'-0"	5,700 lbs
Superior 42	B17A	35'-0" to 60'-0"	33'-6"	25'-3"	42'-0"	19,000 lbs*
Superior 52	B18	52'-0"	41'-6"	31'-4"	52'-0"	19,200 lbs*
Superior 62**	B20	62'-0"	49'-6"	37'-4"	62'-0"	17,000 lbs.

Notes: Field assembly is required for Superior 32+10 (B14), Superior 32+10+10 (B15), and Superior 62 (B20) braces. Fixed length allows for +/-9" of adjustment except Superior 42 (B17A) brace has +/-7.5" of adjustment. Pipe Extensions: T15 for the Superior 22 (B8) model and T20 for the Superior 32 (B12) model.

*Ultimate Load based on adequate brace to HGA or slab connection. **Not available for rental.

Corner Bracing

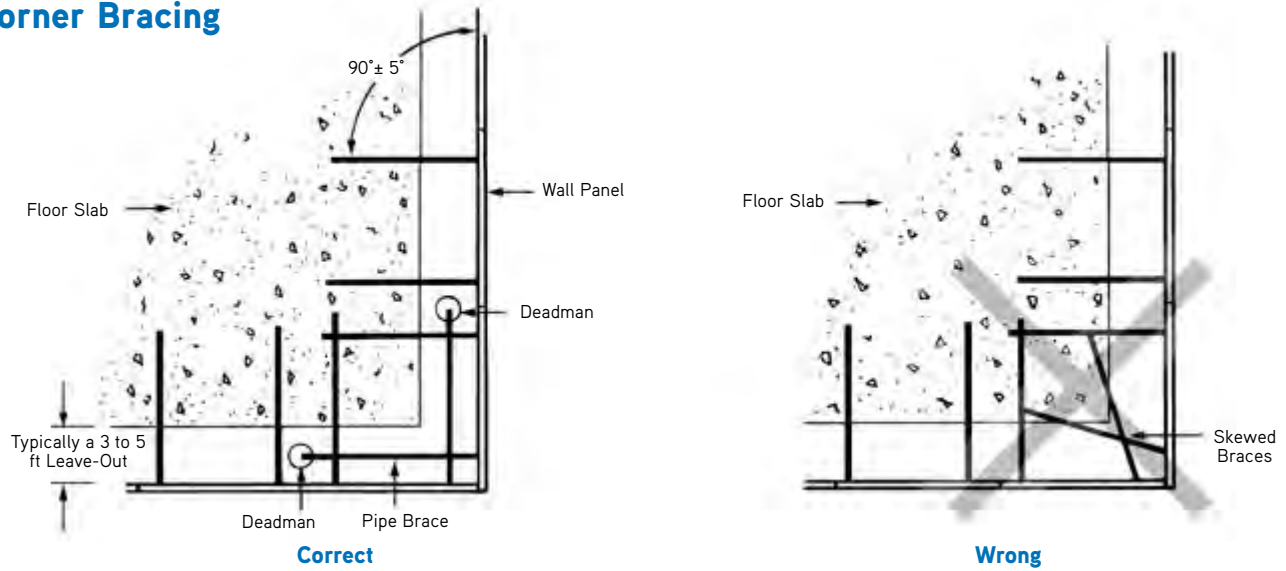

The proper method of bracing corner panels is shown above. Attachment of braces to deadman in the leave-out area allows the braces to be properly located without having to skew the braces for attachment to the floor slab. Corner brace locations must be adjusted during the design process to eliminate pipe interference.

Note: Deadmen should be designed by a qualified engineer based on project specific soil conditions.

Warning! Braces must be installed at $90^{\circ} \pm 5^{\circ}$ to plane of panel or brace safe working load will be drastically reduced. Panel stability may be jeopardized when braces are skewed.

Brace Maintenance

During the construction process braces may be exposed to adverse conditions that could damage or render them unusable. Braces should be inspected for proper operation, damage and wear after each use.

This inspection is typically performed by Dayton Superior or a Dayton Superior Certified Tilt-Up Dealer when the braces are returned. However, when braces are transferred from one job to another without being returned to Dayton Superior or a certified dealer for maintenance, the user must inspect all braces prior to their installation.

This inspection should check for missing parts, wear, dings, kinks, straightness, indication of any application of heat and/or other damage or misuse.

Any brace that shows signs of wear, has missing parts, damage, or is questionable should be set aside and not used.

Our full rental return policy and banding instructions can be obtained from the Tilt-Up Rental Fleet Manager.

Accubrace® Total Bracing System

An integrated, in-line total bracing system designed to decrease labor costs and increase project efficiency.

The Accubrace Total Bracing System is designed for rapid installation and has the ability to immediately load the helical ground anchor for unsurpassed speed and efficiency on tilt-up or precast projects. Bracing products are available at regional offices and can quickly be transported to job sites.

Custom braces can also be designed and manufactured to meet any project application.

Dayton Superior provides safe engineered solutions by installing Helical Ground Anchors (HGAs) and renting necessary components.

Features

- HGAs are an engineered alternative to concrete deadmen and/or floor slabs, reducing the associated time and labor costs
- Rapid, all-weather brace installation — capable of immediate loading when used with the helical ground anchor
- Remove and relocate ground anchors if installation of braces requires adjustment
- Anchor location is adaptable — can be installed inside or outside of structure
- Bracing on the outside of wall simplifies structural steel erection especially in multi-story buildings
- Bracing on the outside of the wall eliminates holes in floor slab and vapor barrier
- Integrated in-line connection to the brace utilizing a HGA and Transition Brace Connector (STBC)
- Dayton Superior offers Professional Engineer review and stamp services
- Removable and reusable
- HGAs can be used with any Dayton Superior brace
- May reduce the number of braces needed if HGAs are used with high capacity braces

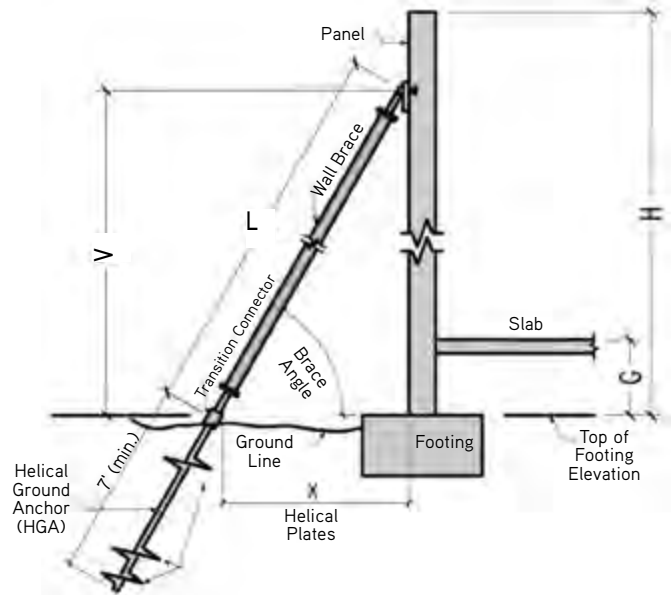

KEY:

L	Brace length	X	HGA Mark - Horizontal distance from panel face
V	Brace connection height above bottom of panel	G	HGA elevation +/- relative to panel bottom
H	Panel height		



Component Overview

Accubrace hardware connectors for braces and helical ground anchors serve as load transfer mechanisms. These connectors are an integral part of the total bracing system.

WARNING: Welding, cutting, or any modification to the HGA, STBC connector, brace, or components is strictly prohibited.

Helical Ground Anchors and HGA Extensions

- Helical Ground Anchors are an engineered alternative to concrete deadman and/or floor slabs
- Dayton Superior installs, removes, and rents HGAs, and provides documentation for each HGA installed
- A general review of the project Geotechnical report prior to the installation date is recommended, and included with the service
- Contractor is responsible for preparing the HGA layout prior to crew arrival
- Certain sites with lower strength foundation soils may require HGA Extensions.

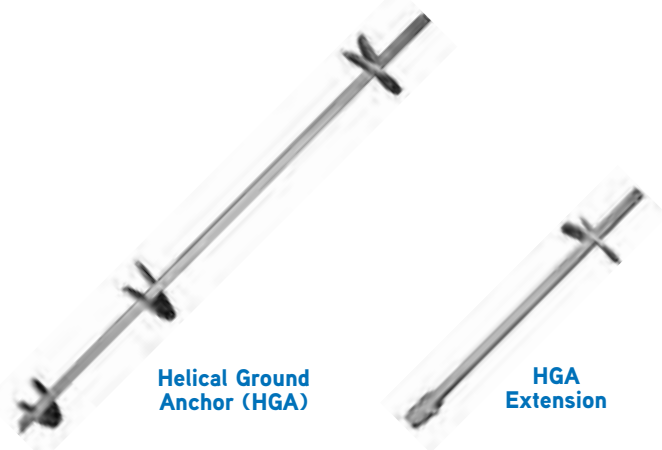

Transition Brace Connectors and Braces

Standard Transition Brace Connector (STBC)

- STBC quickly connects the brace to the HGA with center-line alignment
- Use 5/8" Grade 8 L Pin to connect STBC to brace and 3/4" Grade 8 L Pin to connect STBC to HGA
- Alternative Method: use 5/8" full shoulder Grade 8 bolt with locking nut to connect STBC to brace and 3/4" full shoulder Grade 5 bolt with locking nut to connect STBC to HGA

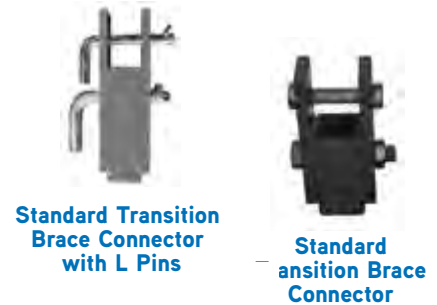

Brace-to-Wall Connection

- Standard Wall and Floor Plate Braces – standard on most round braces
- Two-hole wall plate for higher loads – standard on B18 braces
- Optional four-hole AWPP1 foot plate
- Use T13 or Bearcat Bolt post installed brace anchor or T6A-Heavy, T6B, T6S, T5A, T5A HVY, T5B brace inserts to connect wall plates to wall panels



PCN	Description	SWL	Length
139721	Standard HGA (1-1/2" Square Bar with 10" Helical Plates)	12,000 lbs	7'-0"
139718	Std. HGA Extension (1-1/2" Square Bar with 10" Helical Plates)	15,000 lbs	4'-0"
139722	Standard Transitional Brace Connector (STBC)	15,000 lbs	
100221	Twin Standard Transitional Brace Connector (STBC)	15,000 lbs	
122514	Standard Wall and Floor Plate Bracket		
100308	Single-Hole Wall and Floor Plate Bracket for B42R19R (B17A)		
121954	2-Hole Wall & Floor Plate Bracket for Accubrace		
146283	Two-Hole Wall and Floor Plate Bracket for B52R19R (B18) Braces		
139717	Four-Hole Wall and Floor Plate (AWPP1) - optional		
49206	T13 Coil-Anchor with Tang (3/4" x 4-1/2")		
123045	T13 Coil-Anchor with Tang (3/4" x 6")		

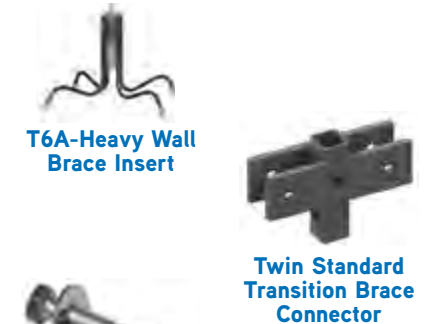

NOTES: When an extension is used, the working load of the HGA increases to 15,000 lbs for the installed torque of 2,200 ft-lb
Safe Working Load is based on 2:1 Safety Factor



T13 Tang Bolt

Installation:

1. REMOVE the foot plate.
2. Use the approved Dayton Superior Standard Transitional Brace Connector (STBC).
3. Attached STBC to the brace using 5/8" Grade 8 L pin with locking cotter pin or 5/8" Grade 8 bolt with locking nut.
4. Attach STBC to HGA using 3/4" Grade 8 L pin with locking cotter pin or 3/4" Grade 5 bolt with locking nut.

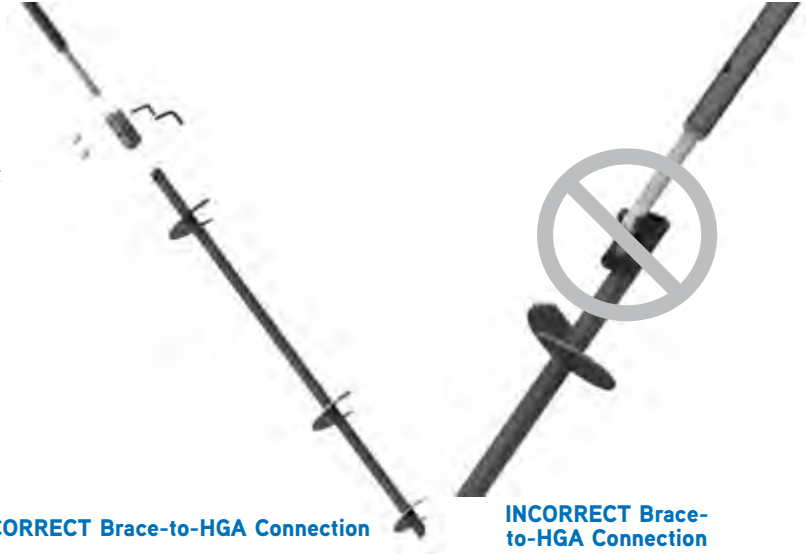

CORRECT Brace-to-HGA Connection

INCORRECT Brace-to-HGA Connection

Steps for a Successful Installation

- Provide Dayton Superior with least five business days notice to mobilize its equipment and crews to the project site.
- A general review of the project Geotechnical report prior to the installation date is recommended, and included with the service.
- Please note that a Geotech report does not cover the entire project foot print, and is only an indication of soil conditions. Unfavorable conditions are always a possibility.
- Contractor is responsible for preparing the HGA layout prior to crew arrival. Layout includes:
 - Marking the horizontal distance from the panel face to the HGA location.
 - Minimum 3' clearance from top of HGA to casting slab or *other* obstacles.
- Contractor to advise Dayton Superior representative of any changes to panel book HGA elevations.
- Contractor is responsible for location of any underground utilities. Any subsurface structure or utility near the anchor locations shall be clearly marked.
- **WARNING:** Installation of anchors underneath utilities or subsurface structures is strictly prohibited.
- HGA marks need to be free of debris and accessible by a skid steer.
- The contractor is to undergo preventive measures to mitigate soil erosion adjacent to installed anchors.
- Contractor is responsible for lost and damaged HGAs. Dayton Superior recommends flagging the HGAs when the braces have been removed to avoid damage and loss.
- Dayton Superior needs the cell phone number and/or email address for the onsite Superintendent. Dayton Superior will confirm with the on-site Superintendent the day prior to the HGA installation
- Dayton Superior will coordinate the arrival of the HGAs and/or braces with the on-site Superintendent as third-party shipping is the normal delivery method.
- Dayton Superior will band the HGAs as they are removed, and load if the contract carrier is available. If not available, the HGAs will be stacked as directed by the onsite Superintendent.
- If braces are supplied with the HGAs, the contractor is responsible for properly stacking the braces for the return transportation.



Bearcat™ Bolt - Multi-Use & Single-Use

The Dayton Superior Bearcat™ Bolt is a high strength drill-in screw anchor. This anchor utilizes a pre-drilled hole and self-taps into the concrete, creating a mechanical connection between the concrete and the anchor threads. The primary use of the Bearcat Anchor Bolt is for anchoring tilt-up wall braces to floor slabs during panel erection. Additional uses include lift brackets/plates as well as permanent or temporary fixation of racking, rails, guards, etc.

Advantages

- High capacity to maximize brace system
- Compatible with 3/4" drilled holes
- Quick and clear installation
- Works in a wide variety of applications
- Better bite into concrete
- No spinning or slipping in hole

In-Concrete, Multi-Use Ultimate Capacity ^{1,2,3,6}							
Screw Anchor Size	Concrete Thickness	Minimum Concrete Compressive Strength (psi)					
		2500		4000		6000	
		Tension ⁴ (lbs.)	Shear ⁴ (lbs.)	Tension ⁴ (lbs.)	Shear ⁴ (lbs.)	Tension ⁴ (lbs.)	Shear ⁴ (lbs.)
5" Bearcat Bolt	4"	5,766	7,327	7,298	9,268	8,936	11,351
	5"	6,689	10,872	8,459	13,752	10,356	16,843
	6"	8,098	11,909	10,250	15,064	12,126	18,449
	7"	8,098	12,765	10,250	16,147	12,126	19,776
	8" and up	8,098	12,765	10,250	16,147	12,126	19,776
7" Bearcat Bolt	6"	11,035	16,621	13,955	21,024	17,095	23,390
	7"	13,655	20,414	17,270	23,390	21,155	23,390
	8"	15,540	21,823	19,660	23,390	23,260	23,390
	9"	15,540	23,147	19,660	23,390	23,260	23,390
	10" and up	15,540	23,390	19,660	23,390	23,260	23,390

¹A minimum recommended safety factor of 2.0 should be applied to these ultimate (nominal) capacities. Check project requirements or local jurisdictions. ²Linear interpolation of embedment depths and concrete strengths are not permitted. ³Tension testing was conducted in 4,900 psi concrete. ⁴Shear values were obtained through ACI 318-19, Chapter 17 Calculations. ⁵Refer to the Tilt-Up Concrete Association's Guide for Temporary Wind Bracing of Tilt-Up Concrete Panels During Construction for more information. ⁶Capacities were obtained through testing of anchors that passed the diameter requirements of the reusability gauge.

Temporary Tilt-Up Bracing Applications ⁵							
In-Concrete, Single-Use Ultimate Capacity ^{1,2,3}							
Screw Anchor Size	Concrete Thickness	Minimum Concrete Compressive Strength (psi)					
		2500		4000		6000	
		Tension ⁴ (lbs.)	Shear ⁴ (lbs.)	Tension ⁴ (lbs.)	Shear ⁴ (lbs.)	Tension ⁴ (lbs.)	Shear ⁴ (lbs.)
5" Bearcat Bolt	4"	8,317	7,327	10,520	9,268	12,884	11,351
	5"	10,376	10,872	13,125	13,752	16,074	16,843
	6"	12,012	11,909	15,194	15,064	18,609	18,449
	7"	12,012	12,765	15,194	16,147	18,609	19,776
	8" and up	12,012	12,765	15,194	16,147	18,609	19,776
7" Bearcat Bolt	6"	13,298	16,621	16,821	21,024	20,601	23,390
	7"	18,363	20,414	23,228	23,390	28,448	23,390
	8"	20,374	21,823	25,772	23,390	31,564	23,390
	9"	20,374	23,147	25,772	23,390	31,564	23,390
	10" and up	20,374	23,390	25,772	23,390	31,564	23,390

¹A minimum recommended safety factor of 2.0 should be applied to these ultimate (nominal) capacities. Check project requirements or local jurisdictions. ²Linear interpolation of embedment depths and concrete strengths are not permitted. ³Tension testing was conducted in 4,900 psi concrete. ⁴Shear values were obtained through ACI 318-19, Chapter 17 Calculations. ⁵Refer to the Tilt-Up Concrete Association's Guide for Temporary Wind Bracing of Tilt-Up Concrete Panels During Construction for more information.

Multi-Use & Single-Use Bearcat Bolt Setting Detail		
	5" Bearcat Bolt	7" Bearcat Bolt
Maximum Mounting Plate Thickness ¹	1"	
Minimum Mounting Plate Hole Diameter	15/16"	
Total Shank Length	5.25	7.25"
Nominal Full Embedment ¹	4.25"	6.25"
Minimum Edge Distance	12"	15"
Over-drill Depth ²	0.50"	
Nominal Drill Bit Diameter	3/4"	
Socket/Hex-head Size	1-1/8"	
Installation Torque ³	200 ft.-lbs.	

¹Ultimate capacities were obtained using a 1" plate thickness. Thicker plates will reduce the capacity. ²Over-drill depth is assuming full anchor embedment in the panel. With panels thinner than the nominal full embedment, the anchor will protrude through the back of the panel. Reference the loading chart for thin panel capacities. ³Over torquing can damage the anchor and/or reduce the capacities.

- **Multi-use bolt** can be used multiple times* with use of wear gauge
 - **Single-use bolt** eliminates the need to restock used bolts
- *results may vary*



Multi-Use Bearcat Bolt

Testing per ACI 355.2-19 and AC193 has been completed on the Single-Use Bearcat Bolt through a third party independent laboratory. Updated Tables for single-use, multi-use, and temporary tilt-up applications are shown below and can be found with the TDS for the respective products.

Industry standard ACI 355.2-19 testing in both cracked and uncracked will allow specifying engineers and users to verify specific performance capacity through ACI 318-19 Chapter 17 calculations. This testing also includes data for seismic applications to allow for even greater application range.

With this testing, the Bearcat Bolt can be used with greater confidence and has qualified acceptance in a variety of applications, including: tilt-up bracing, seismic anchoring and bracing, formwork, variety of permanent connections, sill plates, racking/shelving, hand/guardrails, and many more!



Single-Use Bearcat Bolt

The following parameters are the result of third-party testing in accordance with ACI 355.2-19 and AC193.

Installation Parameters ^{2,3}					
Characteristic	Symbol	Units	5" Bearcat	7" Bearcat	12" Bearcat
Outside Diameter	d_o	in.	0.75	0.75	0.75
		mm.	19.1	19.1	19.1
Nominal Embedment Depth	h_{nom}	in.	4.25	6.25	11.25
		mm.	108	159	286
Effective Embedment Depth	h_{ef}	in.	3.33	5.03	9.28
		mm.	85	128	236
Minimum Hole Depth	h_{hole}	in.	4.75	6.75	11.75
		mm.	121	171	298
Maximum Installation Torque	$T_{inst,max}$	ft•lbf	305	305	305
		N•m	414	414	414
Maximum Impact Driver Installation Torque	$T_{impact,max}$	ft•lbf	305	305	305
		N•m	414	414	414
Minimum Concrete Thickness	h_{min}	in.	6	8	16
		mm.	152	203	406
Critical Edge Distance	c_{ac}	in.	10	18	22
		mm.	254	457	559
Minimum Edge Distance and Spacing	c_{min}	in.	3.25	2.25	1.75
		mm.	83	57	44
	s_{min}	in.	3	3	3
		mm.	76	76	76
Steel Strength ^{2,3}					
Characteristic	Symbol	Units	5" Bearcat	7" Bearcat	12" Bearcat
Outside Diameter	d_o	in.	0.75	0.75	0.75
		mm.	19.1	19.1	19.1
Nominal Embedment Depth	h_{nom}	in.	4.25	6.25	11.25
		mm.	108	159	286
Effective Steel Stress Area	A_{se}	in ²	0.407	0.407	0.4072
		mm ²	262.7	262.7	262.7
Minimum specified ultimate strength	f_u	psi.	125,000		
		N/mm ²	862		
Minimum specified yield strength	f_y	psi.	100,000		
		N/mm ²	689		
Steel Strength in tension	N_{sa}	lb.	40,715		
		kN	181.1		
Steel Strength in shear	V_{sa}	lb.	23,390		
		kN	104.04		
Steel Strength in shear, seismic	$V_{sa,eq}$	lb.	17,100		
		kN	76.06		

Design Strength ^{2,3}					
Characteristic	Symbol	Units	5" Bearcat	7" Bearcat	12" Bearcat
Outside Diameter	d_o	in.	0.75	0.75	0.75
		mm.	19.1	19.1	19.1
Nominal Embedment Depth	h_{nom}	in.	4.25	6.25	11.25
		mm.	108	159	286
Pullout Strength uncracked concrete	$N_{p,uncr}$	lb.	-	-	30618
		kN	-	-	136.2
Pullout Strength cracked concrete	$N_{p,cr}$	lb.	-	-	20538
		kN	-	-	91.36
Pullout Strength cracked concrete, seismic	N_{se}	lb.	-	-	20538
		kN	-	-	91.36
Category Name	1,2,or 3	-	1	1	1
Effective Factor for uncracked concrete	k_{uncr}	-	27	27	24
Effective Factor for cracked concrete	k_{cr}	-	21	21	17
Modification factor for absence of cracks	$\Psi_{c,N}$	-	1.29	1.29	1.49
Pryout Factor	k_{ep}	-	1	1	1
Axial Stiffness in service load range in uncracked concrete	β_{uncr}	lb/inch	368,466	514,973	172,701
		N/mm	64,528	90,186	30,245
Coefficient of variation for axial stiffness in service load range in uncracked concrete	v_{uncr}	%	39	34	34
Axial Stiffness in service load range in cracked concrete	β_{cr}	lb/inch	320,755	288,714	162,700
		N/mm	56,173	50,562	28,500
Coefficient of variation for axial stiffness in service load range in cracked concrete	v_{cr}	%	79	23	21
Normalization Exponent, Uncracked Concrete	n	-	0.5 ¹	0.5 ¹	0.45 ¹
Normalization Exponent, Cracked Concrete	n	-	0.5 ¹	0.5 ¹	0.50 ¹

¹The normalization exponent (n) for the shallow and middle embedment is recommended to be 0.5, as concrete failure mode is shown to control for these sizes. ²The information presented in this table is to be used in conjunction with the design criteria of ACI 318-19 chapter 17, ACI 318-14 Chapter 17 or ACI 318-11 Appendix D, except as modified below. ³The strength reduction factor applies when the load combinations from the IBC or ACI 318 are used and the requirements of ACI 318-19 17.5.3, ACI 318-14 17.3.3 or ACI 318-11 D.4.3, as applicable, are met. If the load combinations of ACI 318-11 Appendix C are used, the appropriate strength reduction factor must be determined in accordance with ACI 318-11 D.4.4.

Bracing Information

T13 Coil-Anchor™ 3/4" Diameter x 4-1/2" Long Application Sequence

1. Drill a 3/4" diameter hole perpendicular to the floor surface with a new carbide tipped drill. Depth of the hole must be a minimum 4". Holes drilled through slabs that are 5" or greater are acceptable. Do not use core bits for T13 anchor holes. Minimum edge distance for the T13 anchor is 12".

Warning! Do not use T13 (4-1/2") anchors in slabs less than 5" thick. The insufficient embedment depth will not allow required load capacity.

Caution must be used when drilling through slabs so that there is no blowout at the bottom of the hole. Tang may not fully engage, greatly reducing SWL; or tang may not engage at all, making the hole unusable.

2. Thoroughly clean the drilled hole.

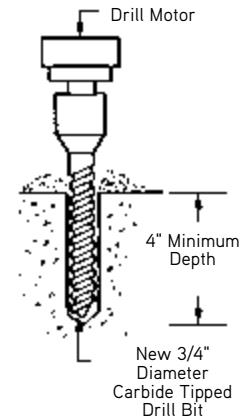

T13 Coil Anchor Bolt
Patent #5,006,023
3/4" Dia. x 4-1/2" Long

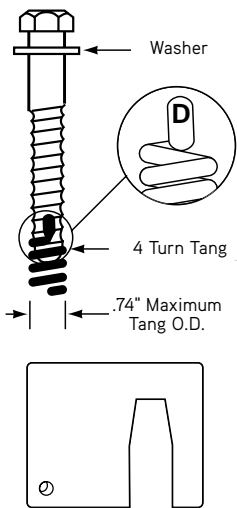

3. Thread the Tang onto the T13 bolt. Finger tight is sufficient, no more than 1-1/2 turn.

Caution! Do not attempt to pre-expand the Tang. For proper load capacity, the Tang must not be installed over 1-1/2 turn on the bolt.

Warning! Do not attempt to use a standard coil bolt with the T13 Coil-Anchor Tang. The Coil-Anchor Bolt is a tapered bolt and is not interchangeable with standard coil bolts.

T13G Thread Gauge

Note: T13G Thread Gauges are recommended, to check T13 bolt thread wear, when reusing T13 Coil-Anchor Bolts.

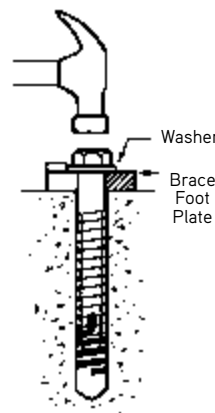

4. Insert the T13 anchor through the foot plate of the wall brace and into the properly drilled hole. Drive the bolt down until the cut washer rests on the foot plate.

Brace Foot Plate



5. Tighten the T13 anchor with a 3/4" impact wrench, then use a torque wrench to insure correct tightness. Refer to the chart for proper torquing values.

Warning! If wind speeds over 35 miles per hour are experienced on the job site, all T13 anchors should be checked with a torque wrench to verify proper torque values are maintained.

6. The Ultimate Load per T13 Coil-Anchor is shown below:

Floor Slab Thickness	Average Ultimate Bracing System Load		Minimum Torque Per Anchor
	fc'=2,500 psi	fc'=4,000 psi	
5" or Thicker	8,924 lbs	11,288 lbs	200 ft lbs

Notes: Ultimate load capacity of this system is based on tension applied at 53 degree angle

Warning: When using T13 Coil-Anchor Bolts, always clean and lubricate the bolt with T13L Set-Eez. Failure to do so will result in bolt wear, lower than expected load capacity and possible premature failure.

T13L Set-Eez™ Dry Film Lubricant

T13L Set-Eez Dry Film Lubricant is designed to facilitate the reuse of the T13 Coil-Anchor bolt. The T13L lubricant is available in 6 oz. jars.



To Order:

Specify: (1) quantity, (2) name.

Example:

4 bottles, T13L Set-Eez Dry Film Lubricant.

T13 Coil-Anchor™ 3/4" Diameter x 6" Long Application Sequence

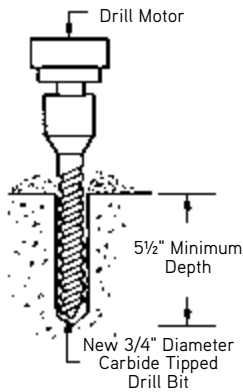

1. Drill a 3/4" diameter hole perpendicular to the floor surface with a new carbide tipped drill. Depth of the hole must be a minimum 5-1/2". Holes drilled through slabs that are 6" or greater are acceptable. Do not use core bits for T13 anchor holes. Minimum edge distance for the T13 anchor is 12".

Warning! Do not use T13 (6") anchors in slabs less than 6" thick. The insufficient embedment depth will not allow required load capacity.

2. Thoroughly clean the drilled hole.

T13 Coil Anchor Bolt
Patent #5,006,023
3/4" Dia. x 6" Long

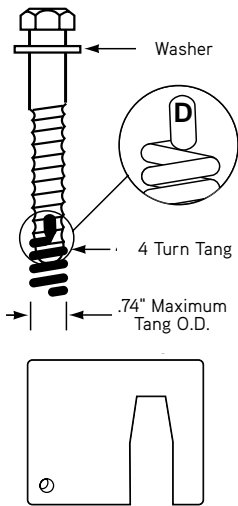

3. Thread the Tang onto the T13 bolt. Finger tight is sufficient, no more than 1-1/2 turn.

Caution! Do not attempt to pre-expand the Tang. For proper load capacity, the Tang must not be installed over 1-1/2 turn on the bolt.

Warning! Do not attempt to use a standard coil bolt with the T13 Coil-Anchor Tang. The Coil-Anchor Bolt is a tapered bolt and is not interchangeable with standard coil bolts.

T13G Thread Gauge

Note: T13G Thread Gauges are recommended, to check T13 bolt thread wear, when reusing T13 Coil-Anchor Bolts.

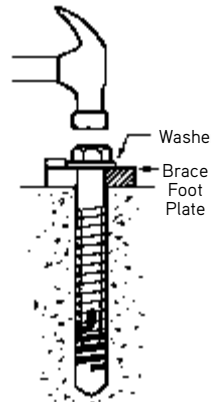

4. Insert the T13 anchor through the foot plate of the wall brace and into the properly drilled hole. Drive the bolt down until the cut washer rests on the foot plate.



5. Tighten the T13 anchor with a 3/4" impact wrench, then use a torque wrench to insure correct tightness. Refer to the chart for proper torquing values.

Warning! If wind speeds over 35 miles per hour are experienced on the job site, all T13 anchors should be checked with a torque wrench to verify proper torque values are maintained.

6. The Ultimate Load per T13 Coil-Anchor is shown below:

Floor Slab Thickness	Average Ultimate Bracing System Load		Minimum Torque Per Anchor
	fc'=2,500 psi	fc'=4,000 psi	
6" or Thicker	13,404 lbs	16,955 lbs	200 ft lbs

Notes: Ultimate load capacity of this system is based on tension applied at 53 degree angle

Warning: When using T13 Coil-Anchor Bolts, always clean and lubricate the bolt with T13L Set-Eez. Failure to do so will result in bolt wear, lower than expected load capacity and possible premature failure.

T4 Brace Anchor for Fill

The Dayton Superior T4 Brace Anchor for Fill is a 3/4" diameter insert designed for anchoring wall braces to the floor slab. The angular offset of the legs provides a gauge and stop when the anchor is pushed into the fill. The T4 anchor is furnished with a T21 Locator Plug factory-installed.

To Order:

Specify: (1) quantity, (2) name, (3) slab thickness.

Example:

120, T4 Brace Anchors for 6" slab.

T4 Brace Anchor for Fill

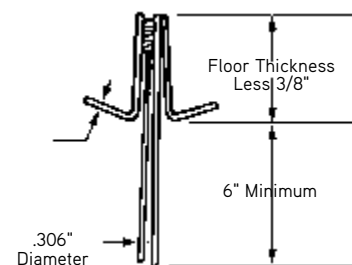

T5A Inverted Wall Brace Anchor

The Dayton Superior T5A Inverted Wall Brace Anchor is designed to place the 3/4" diameter anchorage coil at the bottom of the poured panel. The anchorage is then available for fastening the brace to the cast-down face of the panel after it has been lifted and set in place. The T5A anchor is furnished with plastic tipped feet and a T21 Locator Plug. Standard height of the T5A anchor is 3", minimum panel thickness is 4". Standard height for T5A HVY is 5-1/4", minimum panel thickness is 6".

To Order:

Specify: (1) quantity, (2) name.

Example:

200, T5A Inverted Brace Anchors.

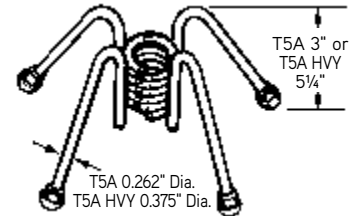

**T5A Inverted Wall
Brace Anchor**

T5A Stick-On Foam Dot Indicator

The Dayton Superior Stick-On Foam Dot Insert Locator for T5A Inverted Brace Anchor is designed to be placed on the T21 locator Plug to create a large visual display on the insert location to make finding the anchor effortless after concrete has set. Sold in quantities of 250.

To Order:

Specify: (1) quantity, (2) name.

Example:

250, T5A Stick-On Foam Dot Insert Locator for T5A Inverted Brace Anchor



T6A-Heavy Brace Anchor

The Dayton Superior T6A-Heavy Brace Anchors are 3/4" diameter coil inserts designed to be easily positioned and tied into the rebar mat of a tilt-up panel. The T6A-Heavy anchors are available with plastic dipped, plastic tipped or stainless steel feet and with a T21 locator plug factory installed. They are used with B14 Coil Bolts.

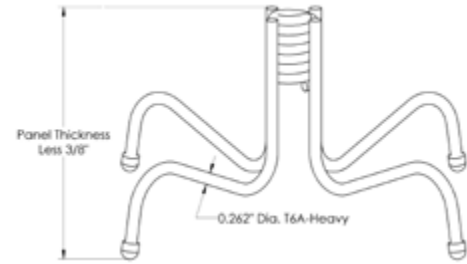

T6A-Heavy Brace Anchor

To Order:

Specify: (1) quantity, (2) name, (3) type of corrosion protection, (4) type of locator plug, (5) slab thickness.

Example:

200, T6A-Heavy Brace Anchors with plastic tipped feet and T21 locator plugs for 6" slab thickness.

Cast-In-Place Brace Anchor Loading

When using Dayton Superior T14 Tilt-Up Pipe Braces, the maximum brace load and ultimate load per brace anchor that can be safely transferred to T4, T5A, T6A-Heavy Brace Anchors are as follows:

Insert Type	Insert Depth	Panel Thickness	Ultimate Load (lbs)		Torque per Anchor	
			Tension	Shear	Minimum	Maximum
T5A	3"	4"	7,794	10,998	80 ft lbs	115 ft lbs
T5A Heavy	5.25"	6"	18,044	22,532	100 ft lbs	140 ft lbs

Insert Type	Panel Thickness	Ultimate Load		Torque per Anchor	
		Tension (lbs)	Shear (lbs)	Minimum	Maximum
T4	5"	12,560	9,840	100 ft lbs	140 ft lbs
T4	7.25"	17,960	19,280	100 ft lbs	140 ft lbs
T6A-Heavy	5"	12,560	9,840	100 ft lbs	140 ft lbs
T6A-Heavy	6"	16,760	14,400	100 ft lbs	140 ft lbs
T6A-Heavy	7"	22,040	19,280	100 ft lbs	140 ft lbs
T6A-Heavy	7.5"	24,840	22,030	100 ft lbs	140 ft lbs
T6A-Heavy	8"	27,780	24,930	100 ft lbs	140 ft lbs

Ultimate Loads are based on 2,500 psi concrete

Maximum Ultimate Load is 20,000 lbs for T5A and 28,500 lbs for T6A-Heavy

Corner or edge distances less than 1.5 times the embedment depth will proportionally reduce these capacities, per ACI 318.

Dayton Superior specifies the use of T4, T5A, T6A-Heavy cast-in-place brace anchors or the T13 Coil-Anchor drill-in brace anchor ONLY. Dayton Superior does not specify or approve any other type of cast-in-place or drill-in anchor for the bracing of tilt-up wall panels. **If any other type of brace anchor is used, the contractor does so at their own risk and assumes the risk of all serious personal injury, death or property damage which may result. By using such unspecified and unapproved brace anchors, the**

T28 Superior Plate Dowel

The Superior Plate Dowel is a two-component product consisting of a plastic sleeve and steel plate that is designed to transfer loads at the joints of concrete floor slabs.

It is used when a slab-to-slab transition occurs and stability of the concrete joint is required. The plastic sleeve is nailed to lumber edge forms and a steel plate then slides into the sleeve.



T28 Superior Plate Dowel

Part Description	Slab Thickness	Spacing
1/4" Sleeve (orange)	5" to 6-1/2"	18"
1/4" Steel Plate	5" to 6-1/2"	18"
3/8" Sleeve (yellow)	7" to 9"	18"
3/8" Steel Plate	7" to 9"	18"
3/4" Sleeve (green)	9" to 12"	18"
3/4" Steel Plate	9" to 12"	18"

To Order:

Specify: (1) quantity, (2) name.

Example:

300, 3/4" Sleeve (green)

P24 Delta Tie

The Dayton Superior P24 Delta Tie is a uniquely insulated connector, designed for used in site casting concrete wall panels. It allows the contractor to fabricate a highly energy-efficient, insulated concrete sandwich wall panel using commercially available, rigid foam insulation.

This versatile connector allows the insulation to be placed from panel edge to panel edge, eliminating thermal bridges and costly energy loss. The insulation is sandwiched between two concrete wythes, or layers, to form a long-lasting, energy-efficient insulated concrete wall panel. The three wythes are tied together using P24 Delta Ties. Spacing of the Delta Ties varies, based on analysis of applied loads during erectio and end use of the panel.

The Delta Tie is produced using an engineered composite matrix. It consists of a geometrically configured, two-dimensional truss manufactured from continuous wound fiberglass embedded in an alkali resistant resin. The design of the Delta Tie produces a connector of remarkable strength and durability.

The non-metallic, non-corrosive design of the Delta Tie greatly reduces any thermal transfer through the panel, increasing the insulating efficiency of the panel.

Advantages

- Stiffer insulated panels
- Design flexibility
- Material, labor and transportation cost reduction
- Quick and easy installation
- Applicable to all brands of foam panel insulation

The standard Delta Tie dimensions are shown in the accompanying detail

The connector is designed so that it can be oriented in the panel either vertically or horizontally, depending on the thickness of the insulation. For example, the 5" x 7" size can be used on its side in a 1" to 2" insulation or on end for 3" to 4" insulation. The Delta Tie can be used with any rigid insulation from 1" to 4" thick. This versatile, dual-use feature adds to the Delta Tie's effective application compatibility and, at the same time, reduces inventory and storage requirements.

In individual connector specimen and full size panel tests the Delta Tie has exhibited excellent loading behavior and load capacities.

Increased Load Bearing

Tests have verified the excellent tension and longitudinal shear strength characteristics of the Delta Tie insulated panel connector.

The P24 Delta Tie has the following ultimate capacities:

Delta Tie Type	Insulation Thickness (inches)	Tension Capacity * (lbs)	Shear Capacity * (lbs)	Orientation
P24 (5"x7")	1" - 2"	3407	3612	horizontal
P24 (5"x7")	3"	2546	1787	vertical
P24 (5"x7")	4"	2136	1360	vertical

* Ultimate Strength per tie is defined as resistance derived as the 5% fractile of the mean ultimate resistance, determined from tests. This is based upon a 90% probability (confidence level) that 95% of ties will exceed the characteristic resistance. Please refer to ACI 355 10.3.

Cost Savings

The Delta Tie design provides a fast and easy installation to save labor. The connector's design flexibility allows the cost saving attributes to be designed into the panel. Delta Tie connectors are purchased as a separate item, allowing the contractor to provide the foam insulation of their choice.

Quick and Easy Installation

The two-dimensional design of the Delta Tie lends itself to easy installation. No drilling or special tools are required. Simply use the rigid insulation as a straight-edge template to quickly place the connectors. Maximum recommended spacing is 8 square feet of panel per panel connector. For spacing greater than 8 square feet of panel per connector, contact Dayton Superior Technical Assistance.



P24 Delta Tie
Patent Pending

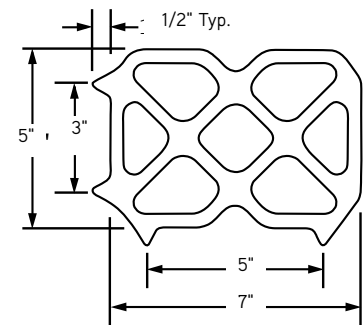

To Order:

Specify: (1) quantity, (2) name.

Example:

500, P24 Delta Ties.

P24 Delta Tie Design Chart

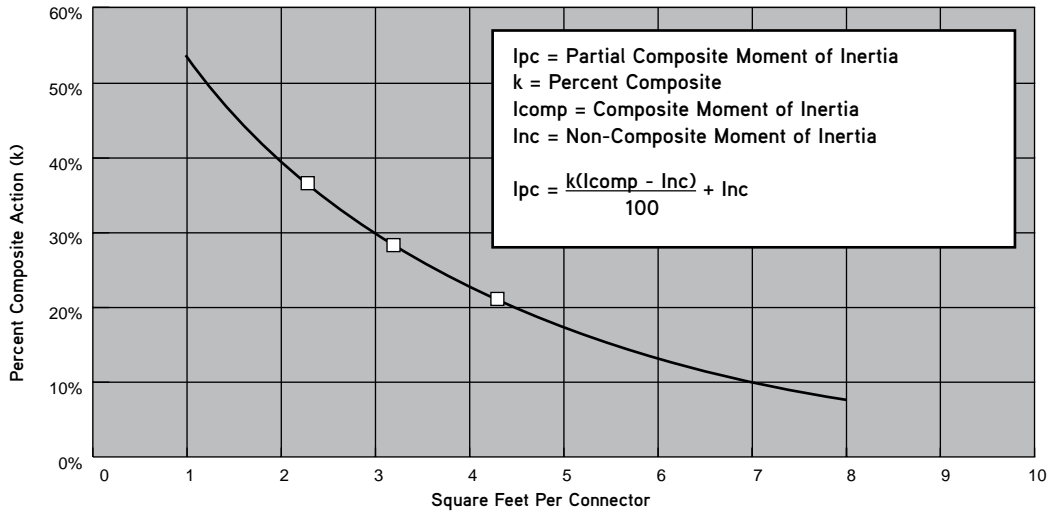

Typical Delta Tie Placement

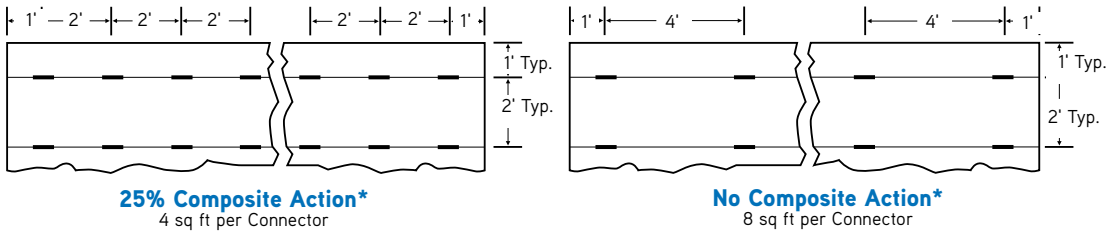

*Note: Percent composite action varies based on the panel geometry, connector pattern, applied load, etc.

Composite Moment Capacity

For any given sandwich panel, the shear and moment diagrams define the required panel stiffness. The panel stiffness may be altered, as necessary, pending panel parameters, by adjusting the tie distribution as a function of the internal shear and moment forces. The two examples, below, illustrate the required stiffness (percent composite action) necessary to develop the shear and moment forces.

1. A panel measuring 37'-0" long by 6'-0" wide, with a 3-2-3 wythe pattern, must have a 5% composite action to achieve a flat lift with 4x2 rigging.
2. A 2-2-2 panel of same size requires a 10% composite action for the same rigging.

In order to employ the least amount of concrete to save weight, the percent of composite action must increase. A small upward adjustment can be realized by a minimal addition of connectors strategically placed at the zones of maximum shear.

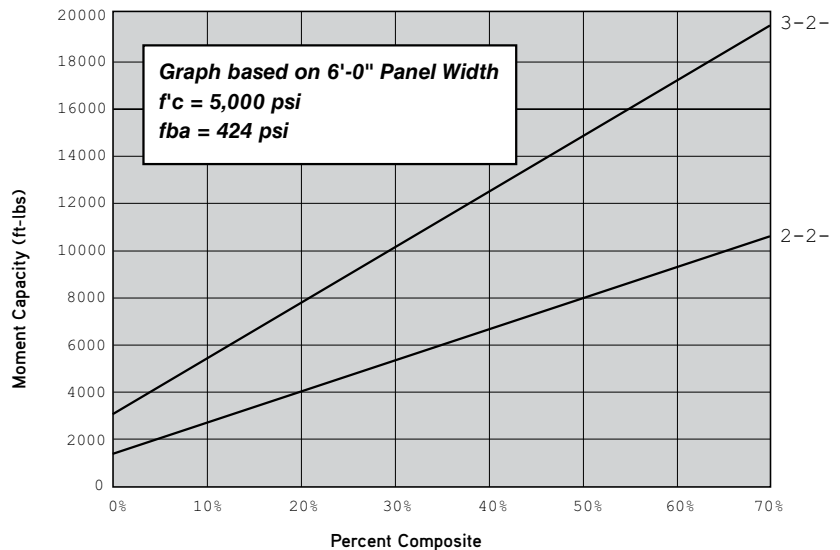

P24XL Delta Tie

The Dayton Superior P24XL Delta Tie is a two-dimensional truss of structurally non-conductive, non-corrosive fiber composite used as a wythe connector for insulated concrete wall panel construction. The P24XL Delta Tie is just like the widely used P24. It is designed for applications with 1" to 5" of insulation.

The P24XL size is 9" x 11" x 5/32" with 1/2" tabs and v-notch installation aids.

Advantages

- The same fast and adaptable installation as the smaller P24
- Use with most commercially available rigid foam insulations
- Up to 75% fewer ties versus comparable systems
- No thermal bridging between wythes
- Provides a range of composite action levels
- Passed ASTM E-119 (4 hr) and NFPA 285 fire testing

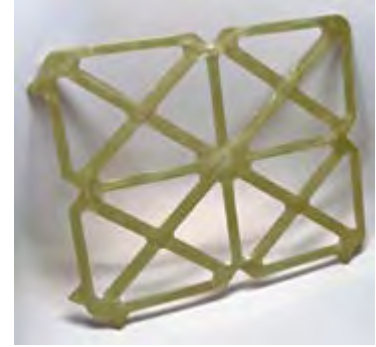

Load Capacities

Delta Tie Type	Insulation Thickness (inches)	Tension Capacity * (lbs)	Shear Capacity * (lbs)
P24XL (9"x11")	1" - 5"	5800	3700
P24XL (9"x11")	6"	3400	3075
P24XL (9"x11")	7"	4000	2800
P24XL (9"x11")	8"	3200	1650

* Ultimate Strength per tie is defined as resistance derived as the 5% fractile of the mean ultimate resistance, determined from tests. This is based upon a 90% probability (confidence level) that 95% of ties will exceed the characteristic resistance. Please refer to ACI 355 10.3.

Delta Tie Installation Information

How is Spacing Achieved in the Field?

Dayton Superior recommends 2'-0" wide x 8'-0" long sheets of extruded insulation foam when using the P24 Delta Tie. This allows the contractor to space ties at 2'-0" centers across the width of the panel and then vary the vertical spacing depending on percentage of composite action desired. Sheets, 2'-0" x 8'-0", can be utilized for other spacing.

What are the Installation Steps for the Delta Tie?

1. Install the required reinforcing, then place and screed the concrete for the outer wythe to its designed thickness.
2. Cut the first strip of foam to a width not exceeding 12" and place it tightly against the side of the form and on top of the just placed concrete while concrete is still in its wet or plastic state.
3. Insert the first row of Delta Ties tight against the edge of the foam, spaced vertically from top to bottom of panel. Minimum tie embedment into the fresh concrete is 1-1/2".
If the tie hits the reinforcing mesh prior to reaching its minimum embedment depth, move the tie slightly so that the reinforcing mesh sits in the depressed "V" section of the tie.
4. Place a full 2'-0" wide section of foam tight against the first row of P24 ties, then insert the second row of Delta Ties from top to bottom of panel.
5. Repeat the process across the width of the panel until there is 12" or less between the last full sheet of foam and the side form.
6. Install the last strip of foam cut to size in width, and force it between the last row of Delta Ties and the side form.
7. Once the concrete in the bottom wythe has stiffened, complete the balance of the panel by installing the required reinforcing steel, embeds and concrete. Finish and cure the backside of the panel per the project's specifications.

It is critical and required that Steps #1 through #6 above be completed immediately after the bottom wythe has been consolidated and leveled to required thickness. This is to ensure that the concrete mix is in a wet or plastic state and workable to be able to embed the Delta Tie properly. If the Delta Tie is not embedded into the concrete while the concrete is still plastic, the concrete will not properly flow through the openings in the tie, which "locks" and holds the tie into the concrete. This could result in failure of the panel.

Important Installation Notes:

1. The person that is installing the foam insulation and Delta Ties should lightly step several times on the foam immediately adjacent to and surrounding the tie to make certain concrete is consolidated around the tie and flows in and around the "anchoring" holes in the tie.
2. Set time of concrete varies as a function of many factors, including (but not limited to): mix design, concrete temperature, ambient temperature and mix time. The installer must ensure that the concrete has not reached initial set before ties are installed.
3. As the P24 Delta Tie is a one-way shear connector, meaning it is stronger in one direction than it is in the other direction, care must be taken to make certain it is installed in its intended orientation in the panel.
4. With the Delta Tie visible above the foam, it is easy to verify if the Delta Tie is set at its proper depth. Utilize a tape measure to randomly check that the ties have a minimum of 1-1/2" above the foam.

What Criteria Determines What Direction the Delta Tie Should be Placed (5" or 7" Vertical) with Different Foam Thicknesses?

Delta Ties are installed to achieve a minimum of 1-1/2" in each concrete wythe. The tie is rotated using either the 5" or 7" dimension to achieve this minimum concrete depth. The chart details the correct direction of the Delta Tie based on insulation thickness:

What is the Learning Curve on Installing Delta Ties?

Contractors have been able to learn quickly how to efficiently install the Delta Tie. In fact, at one jobsite, the crew was able to install the ties so quickly that it was estimated they had reduced the time to install the ties and insulation by almost 50% over the time it took to install a competitive system.

Insulation Thickness	Horizontal Dimension of Tie to Panel Face
1"	7"
1-1/2"	7"
2"	7"
2-1/2"	5"
3"	5"
3-1/2"	5"
4"	5"

P27 Yeti-Anchor®

The P27 Yeti-Anchor® is a high performance, non-conductive, non-corrosive continuous glass-fiber reinforced polymer anchor used as a wythe connector for concrete insulated sandwich panel construction.



The Yeti-Anchor is offered for 1.5" (YS) and 2" (YL) concrete embedment and insulation thicknesses of 2" - 4" (see size chart for more information). Additional insulation thicknesses can be offered upon request. The Yeti-Anchor was tested in accordance with ICC-ES AC320, Acceptance Criteria for Fiber-Reinforced Composite Anchors in Concrete. The Yeti also has a 4-hour ASTME-119 fire rating and passed the NFPA 285 fire testing.

APPLICATION

Yeti-Anchors are compatible with a variety of standard, code compliant insulation types. The Yeti-Anchor allows the installer to "self-drill" the anchor through the insulation. This means the user can drill a hole while simultaneously installing an anchor by using a standard 1/2" or 13mm deep well socket. Anchors must be placed at a minimum of 4" and a maximum of 12" from any edge or opening.

FEATURES & BENEFITS

- No thermal bridging between wythes
- Limits occurrence of interstitial condensation
- Provides a range of composite action levels
- Application software to aid with design and layout
- Fast and Flexible installation
- Increased load bearing
- Stiffer panels for easier handling
- Material, labor, and transportation reduction
- Compatible with all code compliant rigid foam insulation

APPROVALS / COMPLIANCE

- ICC-ES AC320, Acceptance Criteria for Fiber-Reinforced Composite Anchors in Concrete.
- 4-hour ASTME-119 fire rating
- Passed the NFPA 285 fire testing



Square-Foot Coverage per Anchor*				
		Insulation Thickness		
		2"	3"	4"
Exterior Wythe Thickness	2"	4 Sq.Ft. (PN: 100531)	4 Sq.Ft. (PN: 100532)	2 Sq.Ft. (PN: 100533)
	3"	4 Sq.Ft. (PN: 100534)	4 Sq.Ft. (PN: 100535)	4 Sq.Ft. (PN: 100536)
	4"	4 Sq.Ft. (PN: 100534)	4 Sq.Ft. (PN: 100535)	4 Sq.Ft. (PN: 100536)

*Spacing provided is the maximum allowed square-foot coverage per anchor for the given wall condition with the 4 to 1 factor of safety assuming an unsupported exterior wythe. It is acceptable to decrease the spacing to allow for easier installation. Spacing does not need to be broken down into perfect squares (i.e. 2 Sq.Ft. could be 1'x2' or 17"x17")

To Order:

Specify: (1) quantity, (2) size, (3) name.

Example:

100, 1.5"D/2"INS, Yeti-Anchor.

	P27 Yeti-Anchor YS	P27 Yeti-Anchor YL
Wythe Thickness Compatibility	2 - <3"	3" and greater
Nominal Concrete Embedment Depth	1.5"	2"
Allowable Tension Load* (lbs.)	2,500 psi	306
	3,000 psi	351
	3,500 psi	396
	4,000 psi	442
	4,500 psi	463
	5,000 psi	485
	5,500 psi	506
6,000 psi	527	873
Allowable Shear Load* (lbs.)	232	232
Insulation Hole Dia. If Not Self-Drilling	5/16"	

*Allowable load provides an industry standard factor of safety of approximately 4 to 1

For installation, post placement or retro fit repair process procedures, please see the (TDS) Technical Data Sheet.

The Yeti Pull-Tester is used in conjunction with the P27 Yeti-Anchor, please reference the TDS for additional details.

P12G Welded Wire Girders

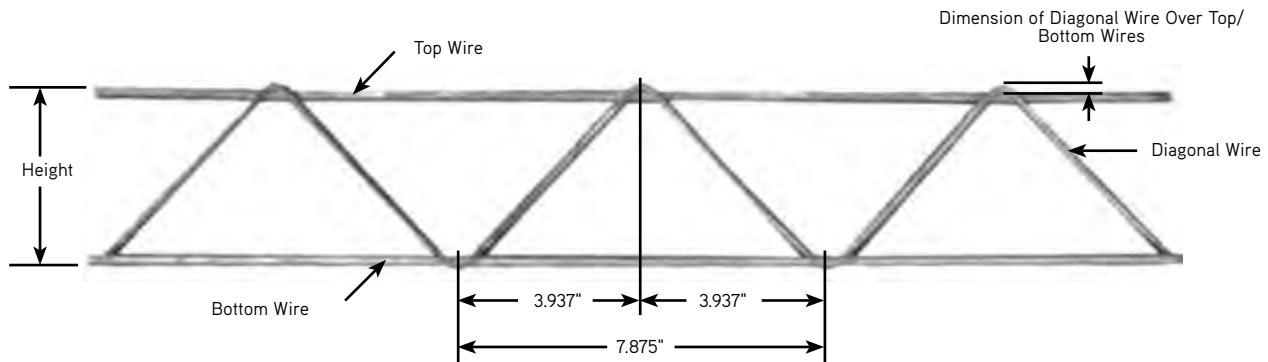

The growth of energy-efficient construction has guided the concrete industry to design and produce cost-effective and time-saving wall panel techniques.

Federal and state energy regulations have driven the popularity of “sandwich panel” walls which feature a layer of insulation “sandwiched” between layers of concrete.

Dayton Superior offers the P12G Welded Wire Girder as one method to meet the need for a unique shear connector adequate to properly transfer or distribute loads between panels.

Dayton Superior girder prevents undesirable energy transfer by eliminating solid concrete sections in the entire panel — no high stress points, no major thermal areas, no cold spots, no wet areas — and a more efficient and cost-effective insulated wall panel.

Most importantly, Welded Wire Girder not only connects the concrete widths through the insulation material, but has the

resiliency to expand and contract with the independent thermal-induced movements of the outer width.

INSTALLATION

1. Install bottom width mesh and place single girder in form, tie to mesh or pre-stressed cables.
2. Pour bottom width concrete, raise or rotate single girder to a vertical position such that 2/3 of the girder is standing out of concrete.
3. Install insulation board in strips between the girder and walk along the insulation board, pressing the insulation board in and around the girder diagonal wires. If any gaps or spaces occur, tape or caulk gaps to prevent concrete from bridging between bottom and top widths.
4. Install top width mesh and tie to girder, or to pre-stressed cables for support and proper positioning in center of top width. Place remaining concrete to form top width.

Top Wire:

- Minimum: 4GA 0.225" diameter
- Maximum: 0GA 0.306" diameter

Bottom Wire:

- Minimum: 4GA 0.225" diameter
- Maximum: 0GA 0.306" diameter

Diagonal Wire:

- Minimum: 6GA 0.192" diameter
- Maximum: 3GA 0.243" diameter

Height:

- 3" to 8.5" in increments of 1/2" (flush style)
- 3" to 9" in increments of 1/2" (set back style)

Length:

- 3'-11" to 34'-5"

Finish:

- Plain or mill galvanized

Pricing:

- Contact Customer Service. All product made-to-order.

How to Order:

- Quantity, name, height, length, wire diameters (top/bottom/diagonal), dimensions of diagonal over top/bottom wire, finish (top/bottom/diagonal).

Manufacturing Location:

- Kankakee, Illinois

P9 Sandwich Panel Tie

The Dayton Superior P9 Sandwich Panel Tie is manufactured to specifications from 3 gauge (0.243" diameter) stainless steel or galvanized wire.

Place the connectors at the edge of the foam insulation so the body of the tie is at the joint line between two pieces of foam. Next, the ends of the tie are rotated 90° so they bear against the foam insulation. Spacing of the panel connectors are per job requirements.

After the panel ties have been attached to the foam insulation, they are placed on the freshly placed bottom wythe of concrete. Later, the top wythe of concrete is placed.

The chart, below, lists the sizes of panel ties produced in the cast for various applications. Other sizes can be produced on special order.

P9 Sandwich Panel Tie

A	3"	4"	4"	5"	6"	7"	8"
B	1"	1"	2"	3"	3"	3"	3"

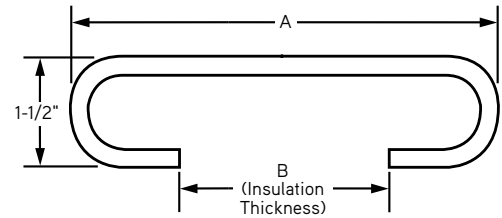

P9 Sandwich Panel Tie

To Order:

Specify: (1) quantity, (2) name, (3) A and B dimensions (4) finish.

Example:

200, P9 Sandwich Panel Ties, A=4", B=2", stainless steel.

P37 "M" Anchor Shear Connector

The Dayton Superior P37 M Anchor Shear Connector is available in various sizes. Fabricated from 1/4" diameter galvanized wire, these connectors are designed for use as a shear connector in concrete sandwich panels. For proper use, place the connectors at the following maximum spacing:

- 18" on center maximum across the width of the panel.
- 24" on center maximum along the length of the panel.
- Place additional connectors around the panel's lift points.

Edge distance requirements are 6" minimum center line to the panel end and 4" minimum center line to the panel's edge. Place connectors parallel to the length of the panel.

Minimum embedment at the open end is 2"

To Order:

Specify: (1) quantity, (2) name, (3) style.

Example:

1200, P37 "M" Anchor Shear Connectors, No. CP107.

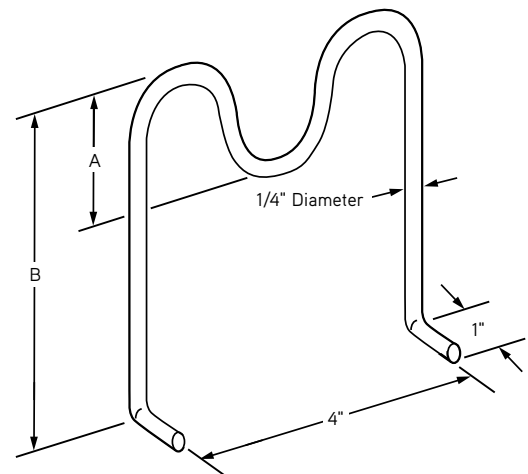

P37 "M" Anchor Shear Connector

P37 "M" Anchor Shear Connectors

Style	A	B	Maximum Insulation Thickness
CP106	2"	6"	2"
CP107	2"	7"	3"
CP206	1-1/2"	6"	2-1/2"
CP207	1-1/2"	7"	3-1/2"

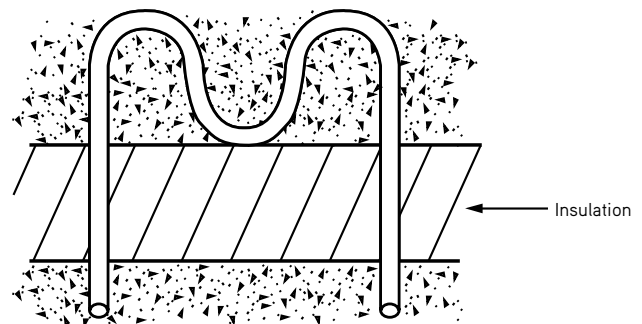

Typical Installation

P30 Corewall® Nut Type Slotted Insert

P31 Corewall® Strap Type Slotted Insert

Corewall inserts are an economical way to connect tilt-up panel to panel or panel to structural building. Corewall Slotted Inserts and accessories are engineered for performance and have proven to be one of the most advanced, adjustable inserts available on the market today. The slotted inserts feature a plastic back and a removable plastic slot cover that keeps the insert clean and saves you valuable time during the erection process.

Corewall slotted inserts from Dayton Superior are available in two different types, the P30 Nut Type Slotted Insert and the P31 Strap Type Slotted Insert. Both types have tabs on each end of the insert for easy attachment to your forms.

The P30 Nut Type Slotted Insert uses a spring loaded, zinc-plated, heavy duty 3/4"-10 National Course (NC) threaded nut to provide fast, efficient and reliable connections. The P31 Strap Type Slotted Insert is used with either the P32 Standard Strap Anchor or the P33 Slotted Strap Anchor, depending upon your erection requirements. The P34 Threaded Strap Anchor is used with the P30 Nut Type Slotted Insert.

The design of the strap anchor allows for fast installation of the anchor into the slotted insert. This speeds up the erection process and saves valuable installation time. As part of the erection process, the strap anchor is welded to the building's structural frame to make a ductile connection. All Corewall products are manufactured from a weldable grade of steel.

Dayton Superior Corewall slotted inserts are ideal for use in precast concrete industrial wall panels, architectural panels, structural panels or precast parking structures. The Corewall slotted inserts are also suitable for use in seismic areas.

P31 Strap Type Slotted Insert

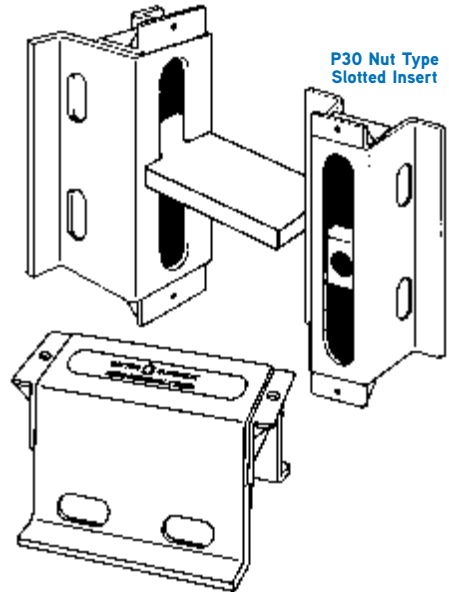

Fast, High Strength, Reliable Concrete Connection Inserts

P30 Corewall® Nut Type Slotted Insert

The Dayton Superior P30 Nut Type Slotted Insert uses a spring loaded, zinc plated, heavy duty 3/4"-10 NC threaded nut to provide fast, efficient and reliable connections. The P30 insert can be used with standard NC threaded bolts or a P34 Threaded Strap Anchor, if a welded connection is required. P30 inserts are available in 4", 6" and 8" standard lengths with either blue epoxy-polyester or hot dipped galvanized (HDG) finish. Type 304 or 316 stainless steel is available on request.



For proper connection to the structural frame of the building, use either a 3/4"-10 NC threaded bolt or rod meeting ASTM A-325 or SAE Grade 5 Standards.

To Order:

Specify: (1) quantity, (2) name, (3) part number, (4) finish.

Example:

200, P30 Corewall Nut Type Slotted Inserts, #CS425, hot-dip galvanized.

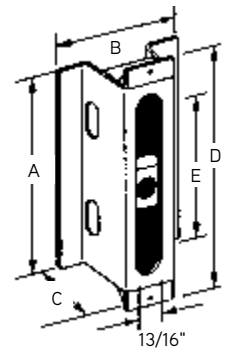

P30 Corewall Slotted Insert Nut Type

P30 Corewall Nut Type Slotted Insert Selection Table

Product Code	Tension Safe Working Load	Shear Safe Working Load	A	B	C	D	Adjustment E
CS425	4,000 lbs.	6,650 lbs.	4"	3-3/16"	2-1/2"	5-1/2"	2-1/2"
CS625	4,000 lbs.	6,650 lbs.	6"	3-3/16"	2-1/2"	7-1/2"	4-1/2"
CS825	4,000 lbs.	6,650 lbs.	8"	3-3/16"	2-1/2"	9-1/2"	6-1/2"
CS435	5,350 lbs.	6,650 lbs.	4"	3-3/8"	3-1/2"	5-1/2"	2-1/2"
CS635	5,350 lbs.	6,650 lbs.	6"	3-3/8"	3-1/2"	7-1/2"	4-1/2"
CS835	5,350 lbs.	6,650 lbs.	8"	3-3/8"	3-1/2"	9-1/2"	6-1/2"
CS445	6,650 lbs.	6,650 lbs.	4"	3-11/16"	4-1/2"	5-1/2"	2-1/2"
CS645	6,650 lbs.	6,650 lbs.	6"	3-11/16"	4-1/2"	7-1/2"	4-1/2"
CS845	6,650 lbs.	6,650 lbs.	8"	3-11/16"	4-1/2"	9-1/2"	6-1/2"

Safe Working Loads provide a factor of safety of approximately 3 to 1 in 5,000 psi normal weight concrete.

P31 Corewall® Strap Type Slotted Insert P32 Corewall® Strap Anchor

P33 Corewall® Slotted Strap Anchor P34 Corewall® Threaded Strap Anchor

The P31 Corewall Strap Type Slotted Insert and the P30 Corewall Nut Type Slotted Insert are both quick and versatile precast concrete connection inserts. When used with the slot running in the same direction as the applied load, the inserts act as a tension tie to the structural frame. However, when the inserts are installed so that the slot runs 90° to the applied load, the inserts can support both shear and tension loads.

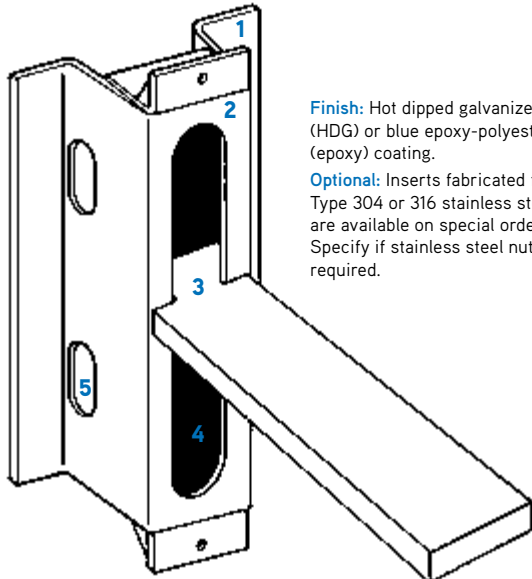

Finish: Hot dipped galvanized (HDG) or blue epoxy-polyester (epoxy) coating.
Optional: Inserts fabricated from Type 304 or 316 stainless steel are available on special order. Specify if stainless steel nuts are required.

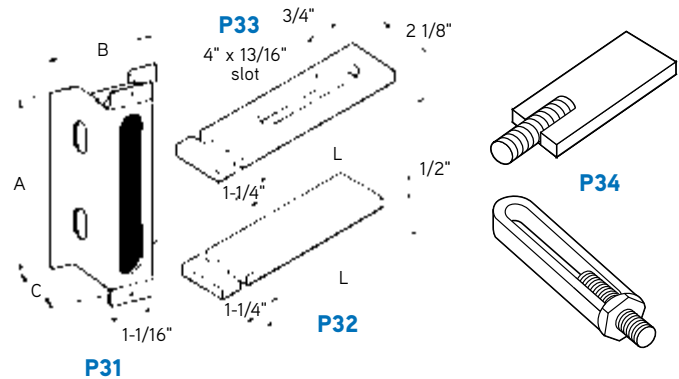

1. Tabs for easy attachment to forms.
2. Weldable grade of steel.
3. Notch in strap anchor assures positive connection to insert
4. Slot allows adjustment for erection tolerances.
5. Slotted holes for extra reinforcement where required.

See following pages for the minimum edge distance requirements needed to develop the tension and shear safe working loads shown in the chart below.

P31 Corewall Strap Type Slotted Insert Selection Table

Insert Style	Tension Safe Working Load	Shear Safe Working Load		A	B	C
		Up to 2" Eccentricity	Up to 3" Eccentricity			
SA 1425	4,000 lbs.	6,650 lbs.	4,000 lbs.	4"	4-3/16"	2-1/2"
SA 1625	4,000 lbs.	6,650 lbs.	4,000 lbs.	6"	4-3/16"	2-1/2"
SA 1825	4,000 lbs.	6,650 lbs.	4,000 lbs.	8"	4-3/16"	2-1/2"
SA 1435	5,350 lbs.	6,650 lbs.	4,000 lbs.	4"	4-3/8"	3-1/2"
SA 1635	5,350 lbs.	6,650 lbs.	4,000 lbs.	6"	4-3/8"	3-1/2"
SA 1835	5,350 lbs.	6,650 lbs.	4,000 lbs.	8"	4-3/8"	3-1/2"

Safe Working Load provides a factor of safety of approximately 3 to 1 in 5,000 psi normal weight concrete. Eccentricity is measured from face of insert to midpoint of the weld connecting the strap anchor to the structural frame.

Corewall Strap Anchor Selection Table

P32 Standard Strap Anchor		P33 Slotted Strap Anchor		P34 Threaded Channel Strap Anchor		P34 Threaded Plate Strap Anchor	
Part Number	Length	Part Number	Length	Part Number	Length	Part Number	Length
CE 806	6"	CE 906	6"	CE 675	6"	CE 600	6"
CE 808	8"	CE 908	8"	CE 875	8"	CE 800	8"
CE 810	10"	CE 910	10"	CE 1075	10"	CE 1000	10"
CE 812	12"	CE 912	12"	CE 1275	12"	CE 1200	12"

Note: Longer lengths are available on special order. The P34 Threaded Strap Anchor is used with the P30 Nut Type Slotted Insert and P38 Slotted Insert II.

Panel Connections

P38 Corewall® Slotted Insert II

Product Description:

The Corewall Slotted Insert II is the next generation product in the Corewall legacy. The design has been improved to create a higher load capacity and greater ease to install the product. With six different product options and two different finishes, the Corewall Slotted Insert II will meet any application. This product is an addition to the Corewall Slotted Inserts which have been specified and used by precasters for over 20 years. The existing styles of Corewall Inserts remain available for use as well.

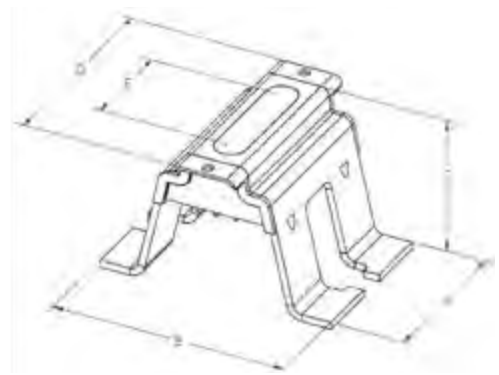

PRODUCT SPECIFICATION:

- 7 gauge one piece steel tapered body
- One piece plastic void former and removable plastic cap
- 3/4" - 10 special nut design
- 3 Insert heights - 2.5", 3.5", and 4.5"
- 3 Insert lengths - 4", 5", 6'
- P34 Threaded Strap Anchor for attachment to building frame

TECHNICAL DATA:

P38 Nut Type Slotted Anchor Insert Selection Table

Description	Tension Safe Working Load	Shear Safe Working Load	Length (A)	Width (B)	Depth (C)	Length (D)	Adjustment (E)
2.5" x 6" P38	5,500lbs.	6,400lbs.	6"	5-1/2"	2-1/2"	7-1/4"	4-1/2"
3.5" x 6" P38	6,750lbs.	8,700lbs.	6"	6"	3-1/2"	7-1/4"	4-1/2"
3.5" x 8" P38	7,100lbs.	8,700lbs.	8"	6"	3-1/2"	9-1/4"	6-1/2"
4.5" x 6" P38	8,800lbs.	10,950lbs.	6"	6-1/2"	4-1/2"	7-1/4"	4-1/2"

Safe Working Loads provide a factor of safety of approximately 3 to 1 in 5,000 psi normal weight concrete. Engineer is responsible to make sure that connecting threaded rod or bolt is strong enough to carry these loads.

Stepped Hairpin Outer Widths for Corner and Edge Detail

Hairpin Parallel to Insert		Hairpin Perpendicular to Insert	
For Insert Height	Hairpin Width	For Insert Length	Hairpin Width
2.5"	4-1/2"	4"	5-1/4" ¹
3.5"	5"	6"	7-1/4" ¹
4.5"	5-1/2"	8"	4" ²

¹Widths listed are for stepped hairpin placement on the outside on the insert. Two Half stepped hairpins should be used if placement inbetween the insert legs are needed. ²4" is the minimum usable width, a maximum width of 5-1/4" can be used.

To Order:

Specify: (1) quantity, (2) name, (3) part number, (4) description, (5) finish.



4.5" x 6" Insert with J-Coating finish

Corewall® Edge and Corner Details

Minimum edge distance, without the use of additional reinforcing steel, is shown below. Edge distance can be reduced if additional reinforcing steel is installed in the insert slots, as shown.

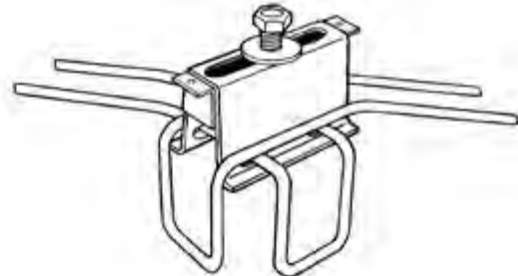
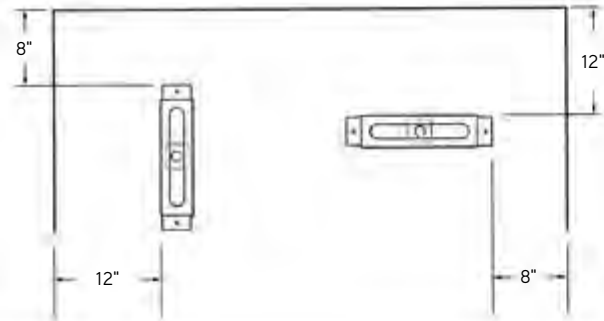

A variety of configurations of extra reinforcing bars can be easily placed through the slotted holes in the legs of the insert. This will allow the insert to be used in seismic areas, as well as close to corners or edges of a precast concrete panel.

<p>Corner Detail-</p> <p>3/4" Minimum Cover</p> <p>3"</p> <p>1-1/4"</p> <p>4" or 6"</p> <p>3/4" Minimum Cover</p> <p>2-#4 Stepped Hairpins</p> <p>Plan</p> <p>Section</p> <p>3/4" Minimum Cover</p>	<p>Edge Perpendicular Detail</p> <p>1-1/4"</p> <p>3/4" Minimum Cover</p> <p>3-#4 Stepped Hairpins</p> <p>Plan</p> <p>Section</p> <p>3/4" Minimum Cover</p>	<p>Slot Details</p> <p>2" 2"</p> <p>4" Insert</p> <p>1-1/2" 3" 1-1/2"</p> <p>6" Insert</p> <p>1-1/2" 1-1/4" C 5/8" 2-1/2" 3" 2-1/2" 11/16"</p> <p>8" Insert</p>
<p>Edge Parallel Detail-</p> <p>3/4" Minimum Cover</p> <p>4" or 6"</p> <p>3"</p> <p>3-#4 Stepped Hairpins</p> <p>Plan</p> <p>Section</p> <p>3/4" Minimum Cover</p>	<p>Corner Detail-</p> <p>3/4" Minimum Cover</p> <p>4" or 6"</p> <p>1-1/4"</p> <p>3"</p> <p>2-#4 Stepped Hairpins</p> <p>3/4" Minimum Cover</p> <p>Plan</p> <p>Section</p> <p>3/4" Minimum Cover</p>	<p>Stepped Hairpin</p> <p>Varies to suit minimum cover</p> <p>#4 Rebar</p> <p>1'-6"</p> <p>3-1/2" Out/Out</p> <p>Half Stepped Hairpin</p> <p>Varies</p> <p>#4 Rebar</p> <p>1'-6"</p> <p>1-3/4" Out/Out</p>

Panel Connections

Corewall® Slotted Insert II – Edge and Corner Detail

Minimum edge distance, without the use of additional reinforcing steel, is shown below. Edge distance can be reduced if additional reinforcing steel is installed in the insert slots, as shown.

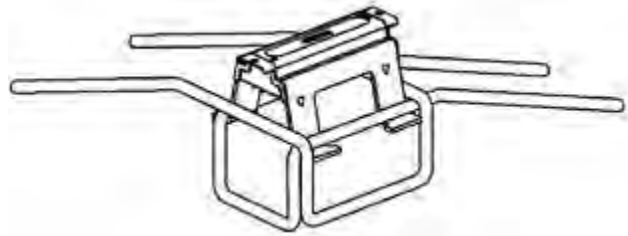
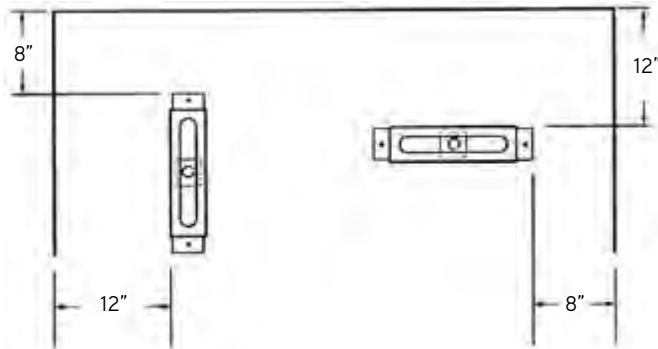

A variety of configurations of extra reinforcing bars can be easily placed through the slotted holes in the legs of the insert. This will allow the insert to be used in seismic areas, as well as close to corners or edges of a precast concrete panel.

Corner Detail

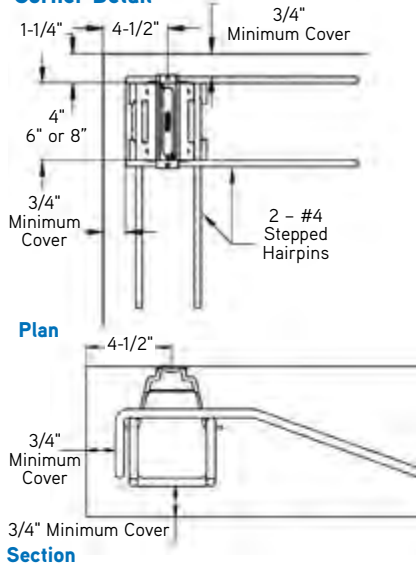

Edge Perpendicular Detail

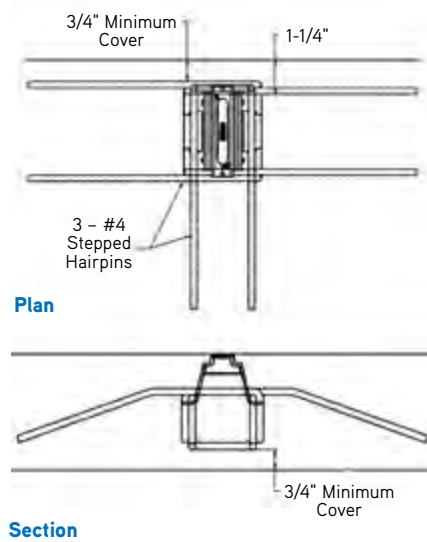

Insert Detail

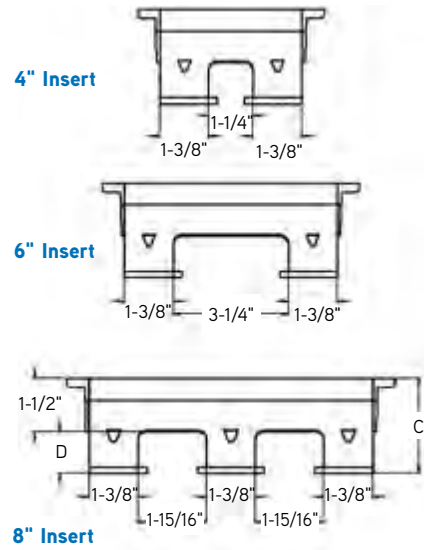

Panel Connectors

Edge Parallel Detail

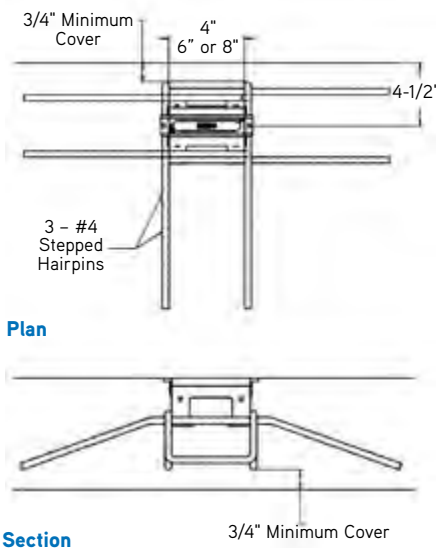

Corner Detail

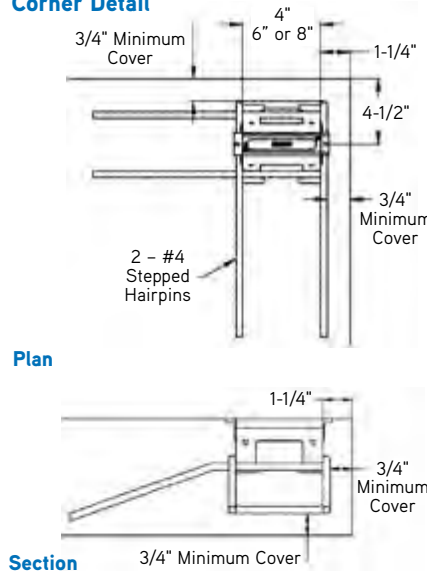

Stepped Hairpin

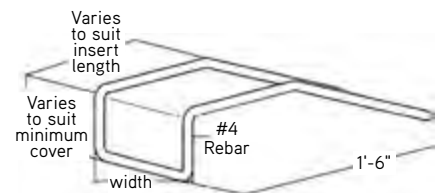

Half Stepped Hairpin

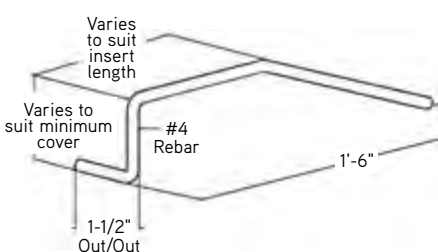

D410 Sleeve-Lock® Grout Sleeve

The Dayton Superior Sleeve-Lock Grout Sleeve is a one-piece mechanical coupler designed to butt-splice reinforcing steel in concrete structures. The Sleeve-Lock is available in seven (7) sizes to accommodate deformed bar sizes #4 through #18. Bars of like size or of different sizes can be effectively spliced by the System. Typical Sleeve-Lock applications include precast, tilt-up and cast-in-place concrete structures.



The Sleeve-Lock is a ductile casting with a minimum yield strength of 55,000 psi and a minimum tensile strength of 80,000 psi. It exceeds all known building codes and agency standards. The System achieves 160% fy strength criteria with the Sleeve-Lock Grout D490 high strength, non-shrink grout.

The Sleeve has several unique features:

- Rebar Stop – An integrated post that acts as a precise stop when inserting rebar
- Alignment Fins – Positioning fins that keep inserted rebar centered
- Standard Port Sizes – Ports designed to accept standard 0.75" SCH40 PVC; ports use the same size PVC
- Stacking Feet – Feet stabilize the product during shipping and on the shelf while assisting in wire-tying and acting as a platform for a rebar chair.
- Made In USA – The sleeve is 100% made in the USA.

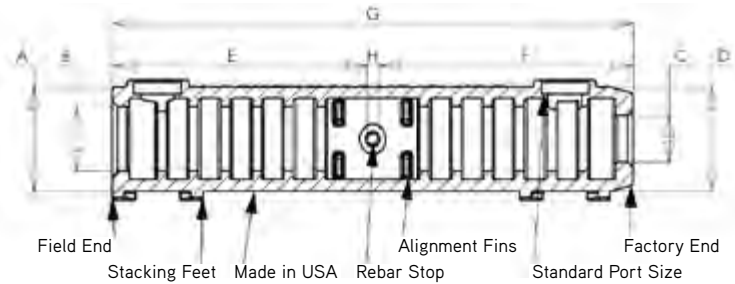

SIZE		SLEEVE-LOCK DIMENSIONS (Inches)						REBAR EMBEDMENT LENGTH			
		A	B	C	D	G	H	E, MAX	E, MIN	F, MAX	F, MIN
#4	13MM	2.14	1.26	0.87	2.14	9.50	0.25	4.63	3.30	4.63	3.30
#5	16MM	2.14	1.26	0.87	2.14	9.50	0.25	4.63	4.13	4.63	4.13
#6	19MM	2.61	1.73	1.14	2.61	13.00	0.25	6.38	4.92	6.38	4.92
#7	22MM	2.61	1.73	1.14	2.61	13.00	0.25	6.38	5.71	6.38	5.71
#8	25MM	2.89	2.01	1.42	2.89	16.52	0.38	8.07	6.50	8.07	6.50
#9	29MM	2.89	2.01	1.42	2.89	16.52	0.38	8.07	7.40	8.07	7.40
#10	32MM	3.04	2.16	1.57	3.04	17.99	0.50	8.75	8.19	8.75	8.19
#11	36MM	3.32	2.32	1.73	3.32	19.54	0.50	9.52	8.98	9.52	8.98
#14	43MM	3.73	2.60	2.01	3.73	24.50	0.50	12.00	11.42	12.00	11.42
#18	57MM	4.77	3.27	2.68	4.77	36.00	0.50	17.75	17.00	17.75	17.00

Approvals/Compliances

- ACI 318-19 Type 2
- ICC AC-133
- CALTRANS Ultimate Splice
- Ministries of Transportation, Canada
- Army Corps of Engineers, CW 03210
- State Departments of Transportation, USA
- AASHTO
- International Building Codes (IBC)
- City of Los Angeles Department of Building and Safety



Sleeve-Lock® Grout Sleeve

"By using the Sleeve-Lock Grout Sleeve, we could make two panels instead of one and use a more maneuverable and smaller crane, while still complying with the tough OSHA safety guidelines. This substitution allowed us to save over \$100K in crane rental costs, lost work time, and decreased efficiencies associated with a larger crane." – Florida Tilt

Sleeve Lock Components

Components are available through Dayton Superior and some are available at local suppliers.

Item No.	Cat ID	Description	Included	Order Separately	Obtain Locally
1	D410	Sleeve-Lock® Grout Sleeve	X		
2	D490	Sleeve-Lock® Grout		X	
3	D487	Sleeve-Lock® Seal Plug		X	
4	D491	Sleeve-Lock® Form Plug		X	
5	D492	Sleeve-Lock® ¾" SCH40 PVC		X	X
6	D493	Sleeve-Lock® Port Plug		X	

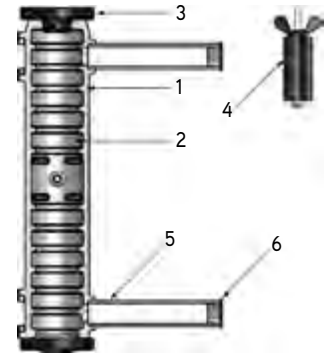

How to Specify:

Specific: Mechanical splices shall be the Sleeve-Lock® Grout Sleeve System manufactured by Dayton Superior Corporation.

Generic: The mechanical connection shall meet building code requirements of developing in tension and compression, as required, by local standards and codes. Grouting must be performed in accordance with the manufacturer's recommended grouting procedures.

D490 Sleeve-Lock® Grout

Sleeve-Lock Grout D490 is specifically designed and manufactured by DSC for the Sleeve-Lock System. It is a flowable grout capable of achieving 11,000ksi when mixed following the recommended mixing instructions. Available in 50lb bags, yield per bag, noting that grout used in PVC tubing is not accounted for, is as shown in table.

Use only potable water for mixing. A 50 pound (22.7 kg) of grout will require approximately 6.5 pints (3.07 liters) of water to achieve a flowable consistency. The water amount can be adjusted +/- 0.5 pints (0.23 liters) to achieve desired consistency. Determine correct water amount by mixing of a test batch prior to commencing grouting operation

	Size	Sleeves / Bag of Grout
#4	13MM	37
#5	16MM	40
#6	19MM	16
#7	22MM	30
#8	25MM	11
#9	29MM	11
#10	32MM	9
#11	36MM	8
#14	43MM	5
#18	57MM	3

Amounts are approximate.

D487 Sleeve-Lock® Seal Plug

The Sleeve-Lock Seal Plug is a rubberized plug used to seal the connection between the Sleeve-Lock Grout Sleeve and the reinforcing bar. It is designed to keep concrete from entering the inner cavity of the Sleeve-Lock Grout Sleeve on the Factory End and to contain the pumped in grout on the Field End. Per size, the Sleeve-Lock Seal Plug can be used on either end meaning that only one size Sleeve-Lock Seal Plug (QTY 2) per sleeve need be stocked.



D491 Sleeve-Lock® Form Plug

The Sleeve-Lock Form Plug is a device using a rubberized grommet and a clamping device and used to attach the Sleeve-Lock Grout Sleeve to a piece of formwork i.e. steel, lumber, composite. It is designed to fasten the sleeve to the formwork while keeping concrete out of the sleeve's inner chamber. It is to be used on the Field End only and is not designed to be used as a structural connection.



D492 Sleeve-Lock® ¾" SCH40 PVC

The Sleeve-Lock ¾" SCH40 PVC is standard, off the shelf, PVC, used to fill the inner chamber of the Sleeve-Lock Grout Sleeve. Either port of the sleeve uses the same size PVC. It is available locally or through DSC.



D493 Sleeve-Lock® Port Plug

The Sleeve-Lock Port Plug is a plastic plug used during jobsite shipping to plug the ports in order to keep debris from entering the inner chamber of the sleeve. They can also be used to plug the PVC before or after grouting. One size will fit either end port or PVC.



When it is time to choose concrete formliners, make your first choice Dayton Superior. For stock or custom orders, we have you covered.

Easy to install and easy to strip, Dayton Superior Formliners come in more than a wide variety of contemporary designs and are available in Single Use and Medium Reuse. Repeat patterns eliminate seam lines.

Best of all, our formliners are labor saving and money saving, and they provide esthetics to your precast project.

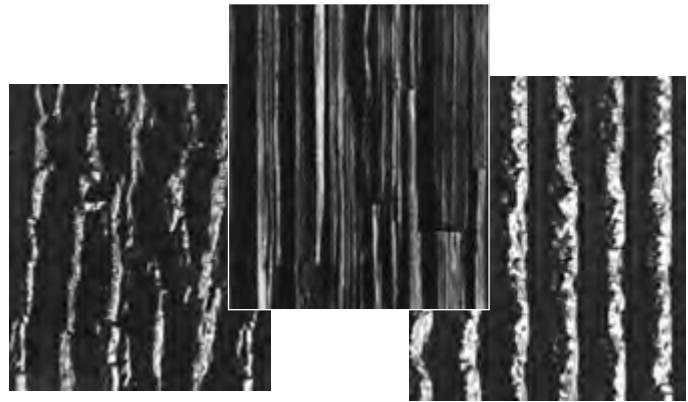

Thermoform™ Vacuum-Formed Formliners

Thermoform Concrete formliners are rigid plastic liners that are used to achieve detailed patterns and textured concrete surfaces for architectural concrete. You may select from a variety of patterns, or custom order to fit your needs – at only a nominal additional cost. All patterns are available in two different ranges: single use and medium reuse.

The single use version, made from styrene, is ideal where the formliner will be used only once. The medium reuse, made from ABS materials, can be used up to 6 times.

The vacuum-forming technology used in this product line allows virtually unlimited texturing opportunities, offering the most flexibility in custom designed patterns. This low cost reproduction process allows you to add exceptional economic options to the design integrity of your concrete projects. Due to the stretching of the plastic sheet material that occurs during the reshaping of the thermoforming process, some patterns with a high degree of texture or relief should not be produced in the thinner, single-use material. Usually supplied in 4' x 10' sheets to cut or combine to produce almost any dimension.



Formliners
Architectural Concrete

Fractured Patterns



Fractured Rope Rib (2" OC rope)
 P/C 230715 0.090 mil Styrene
 P/C 230475 0.110 mil ABS

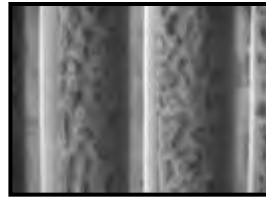

2" Broken Rock Rib (37/16" OC rib)
 P/C 230719 0.150 mil Styrene
 P/C 230451 0.150 mil ABS

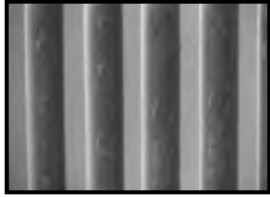

Fine Stone Rib (2" OC rib)
 P/C 230716 0.090 mil Styrene
 P/C 230448 0.110 mil ABS

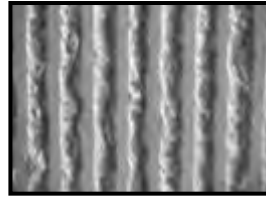

Fluted Fractured Fin (1 1/4" OC rib)
 P/C 230732 0.090 mil Styrene
 P/C 230431 0.110 mil ABS

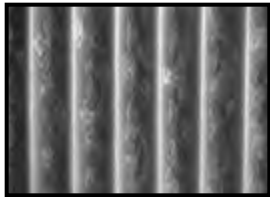

3/4" Fractured Fin (1 1/2" OC fin)
 P/C 230717 0.090 mil Styrene
 P/C 230449 0.110 mil ABS

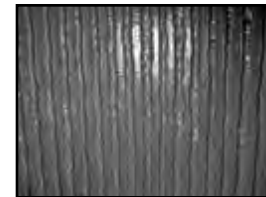

1" Fractured Fin (2.35" OC rib)
 P/C 270341 0.090 mil Styrene
 P/C 270343 0.110 mil ABS

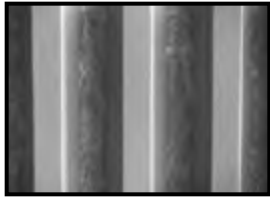

1 3/4" Fractured Fin (3" OC fin)
 P/C 230718 0.150 mil Styrene
 P/C 230499 0.150 mil ABS



1" Fractured Fin
 (2" OC rib; open end)
 P/C 270580 0.090 mil Styrene
 P/C 270505 0.110 mil ABS

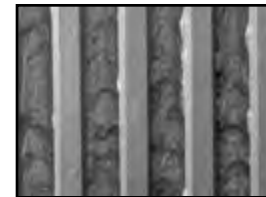

1 1/2" Fractured Fin
 (3" OC rib; open end)
 P/C 270581 0.150 mil Styrene
 P/C 270506 0.150 mil ABS

Wood Patterns

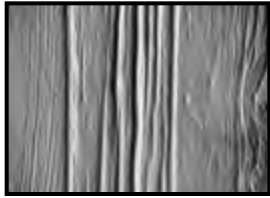

4" Wide Aged Wood
(actual 3 1/2" width)
P/C 230703 0.070 mil Styrene
P/C 230249 0.070 mil ABS

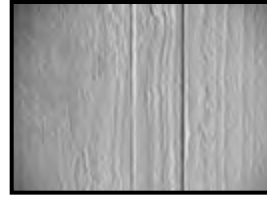

Rough Sawn
Random Length Plank
P/C 230707 0.070 mil Styrene
P/C 230481 0.070 mil ABS

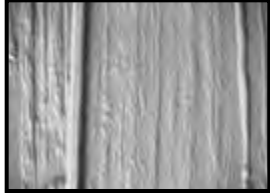

Random Grooved Barnwood
P/C 230704 0.070 mil Styrene
P/C 230450 0.070 mil ABS

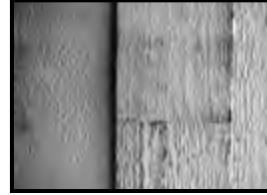

4" Variable Depth Rough Cedar
P/C 947007 0.090 mil Styrene
P/C 940005 0.110 mil ABS
P/C 230618 Dura-Tex Lite
P/C 230921 Elasto-Tex

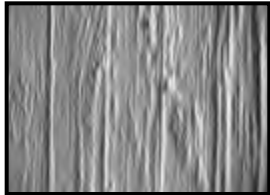

2" Wide Aged Wood
P/C 230705 0.070 mil Styrene
P/C 230479 0.070 mil ABS

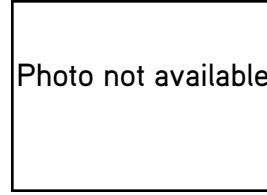

Weathered Wood
P/C 947011 0.070 mil Styrene
P/C 940003 0.070 mil ABS

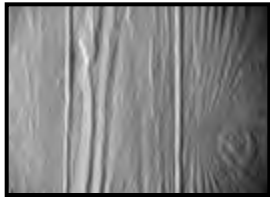

4" Wide Aged Cedar
P/C 230706 0.070 mil Styrene
P/C 230480 0.070 mil ABS

Photo not available

Smooth Flute Patterns

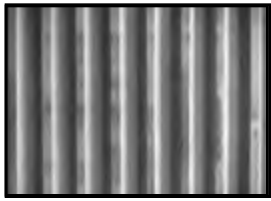

1/2" Deep Rib
 (1 1/4" OC rib; closed end)
 P/C 230709 0.090 mil Styrene
 P/C 230244 0.110 mil ABS

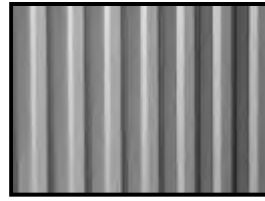

3/4" Deep Rib
 (2" OC rib; open end)
 P/C 270321 0.090 mil Styrene
 P/C 270261 0.110 mil ABS

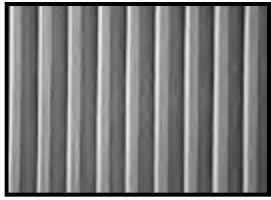

1/2" Deep Rib
 (1 1/2" OC rib; open end)
 P/C 270322 0.090 mil Styrene
 P/C 270262 0.110 mil ABS



3/4" Deep Rib
 (6" OC rib; open end)
 P/C 270323 0.090 mil Styrene
 P/C 270263 0.110 mil ABS

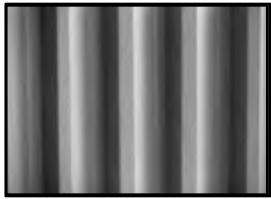

1" Deep Rib
 (2 1/8" OC; rib closed end)
 P/C 230714 0.090 mil Styrene
 P/C 230489 0.110 mil ABS

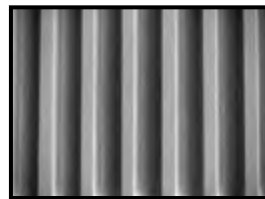

3/4" Deep Rib
 (1 1/2" OC rib; open end)
 P/C 270324 0.090 mil Styrene
 P/C 270264 0.110 mil ABS

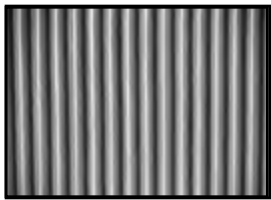

1/4" Deep Rib
 (5/8" OC rib; open end)
 P/C 230708 0.070 mil Styrene
 P/C 230472 0.070 mil ABS



3/4" Deep Special Rib
 (4" OC rib; open end)
 P/C 270325 0.090 mil Styrene
 P/C 270265 0.110 mil ABS



1 1/2" Deep Rib
 (4" OC rib; open end)
 P/C 270320 0.150 mil Styrene
 P/C 270260 0.150 mil ABS



3/4" Deep Rib
 (4" OC rib; open end)
 P/C 270326 0.090 mil Styrene
 P/C 270266 0.110 mil ABS

Block Patterns

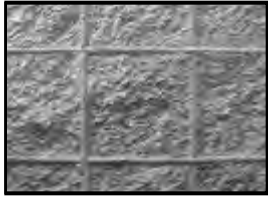

8" x 8" Rock Face Block
 P/C 270330 0.090 mil Styrene
 P/C 270270 0.110 mil ABS



8" x 16" Rock Face Block
 P/C 270331 0.090 mil Styrene
 P/C 270271 0.110 mil ABS



8" x 16" Rock Face Stacked Bond
 P/C 270332 0.090 mil Styrene
 P/C 270272 0.110 mil ABS



8" x 16" Smooth Face Block
 P/C 270333 0.090 mil Styrene
 P/C 270273 0.110 mil ABS



Masonry Slump Block
 P/C 230734 0.090 mil Styrene
 P/C 230426 0.110 mil ABS

Brick Patterns



Rustic Brick
 P/C 230723 0.070 mil Styrene
 P/C 230247 0.110 mil ABS

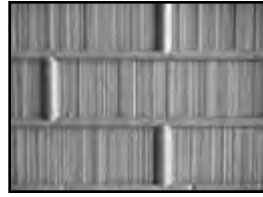

Striated Brick
 P/C 230724 0.070 mil Styrene
 P/C 230222 0.070 mil ABS



2 1/2" x 8" Smooth Brick
 (square mortar)
 P/C 270327 0.070 mil Styrene
 P/C 270267 0.070 mil ABS



2 1/2" x 8" Smooth Brick
 (rounded mortar)
 P/C 270598 0.070 mil Styrene
 P/C 270515 0.070 mil ABS



4" x 12" Smooth Brick
 (on-center square mortar)
 P/C 270328 0.090 mil Styrene
 P/C 270268 0.110 mil ABS

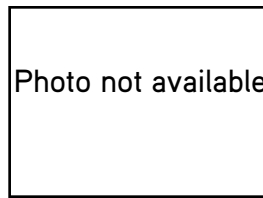

4" x 12" Smooth Brick
 (off-center square mortar)
 P/C 270329 0.090 mil Styrene
 P/C 270269 0.110 mil ABS

Stone Patterns

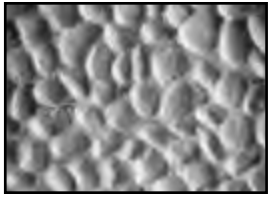

Round Stone
P/C 230722 0.070 mil Styrene
P/C 230251 0.070 mil ABS



Large Dry Stack Stone
P/C 270582 0.150 mil Styrene
P/C 270507 0.150 mil ABS

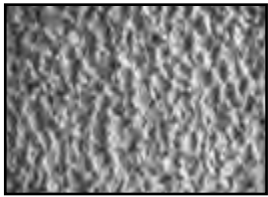

Small Crushed Stone
P/C 230721 0.070 mil Styrene
P/C 230250 0.070 mil ABS



Fractured Concrete
P/C 270583 0.090 mil Styrene
P/C 270508 0.110 mil ABS



Vertical Flagstone
P/C 270559 0.090 Styrene
P/C 270516 0.110 ABS



Colonial Dry Stack
P/C 270593 0.150 mil Styrene
P/C 270510 0.150 mil ABS



Old Ashlar Stone
P/C 230429 0.090 mil Styrene
P/C 230427 0.110 mil ABS

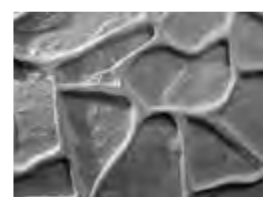

Hill Country Flagstone
P/C 270594 0.150 mil Styrene
P/C 270511 0.150 mil ABS



Southwest Ashlar Stone
P/C 230430 0.150 mil Styrene
P/C 230428 0.150 mil ABS

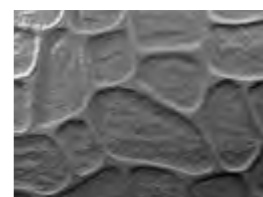

Shallow Fieldstone
P/C 270576 0.090 mil Styrene
P/C 270501 0.110 mil ABS

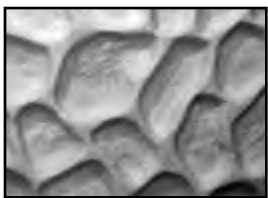

Random Fieldstone Large
P/C 270334 0.150 mil Styrene
P/C 270274 0.150 mil ABS

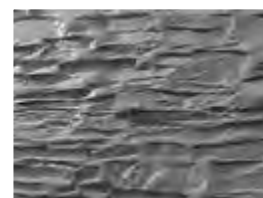

Standard Dry Stack
P/C 270578 0.150 mil Styrene
P/C 270503 0.150 mil ABS

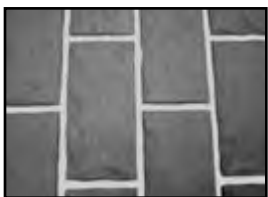

Running Bond Ashlar Stone
P/C 270340 0.150 mil Styrene
P/C 270342 0.150 mil ABS

Other Patterns

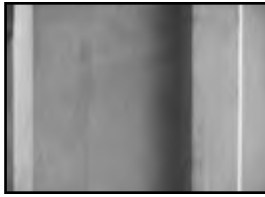

Random Vertical Rustication
P/C 230728 0.150 mil Styrene
P/C 230487 0.150 mil ABS

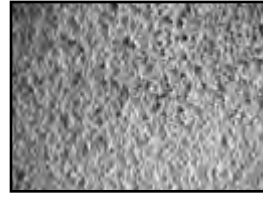

Sandblast - Coarse
P/C 230423 0.070 mil Styrene
P/C 230422 0.070 mil ABS

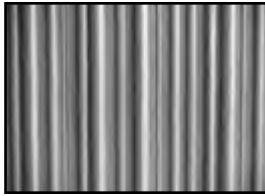

$\frac{3}{8}$ " Striated Random
P/C 230726 0.070 mil Styrene
P/C 230493 0.070 mil ABS



Split Slate
P/C 270597 0.070 mil Styrene
P/C 270514 0.070 mil ABS

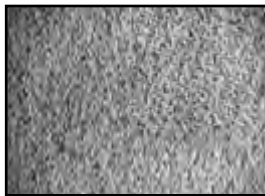

Sandblast - Fine to Medium
P/C 270596 0.070 mil Styrene
P/C 270513 0.070 mil ABS

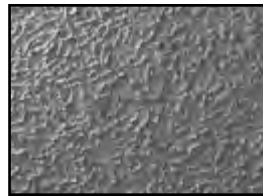

Bush Hammer
P/C 270592 0.090 mil Styrene
P/C 270509 0.110 mil ABS

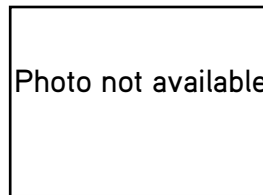

Smooth Sheet
P/C 230702 0.070 mil Styrene
P/C 230435 0.070 mil ABS

Photo not available

Application Guide

Tilt-Up Applications

Single use SPS plastic is most frequently used for Tilt-Up applications. Basic procedures for attachment are as follows:

1. Identify the pour side of the formliner. The pour side can be identified by the roughened, "hair cell" texture or as the side with the highest resolution in the pattern. The shiny or slick side of the liner will be placed against the slab or formwork.
2. Because of the nature of plastic to expand and contract, it may be necessary for the material to be trimmed. The easiest way to cut is to use a circular hand saw (such as a Skilsaw) with a fine tooth, plywood blade such as the type used for cutting fine veneer paneling. Formliner without much relief may be trimmed by scoring with a sharp knife and breaking off the excess.
3. The effects of temperature, thermal expansion and contraction must be considered. The size of the liner will expand and contract approximately 1/16" in 10' with each 10° temperature change. Formliner should be installed at about the same temperature as expected during the placement of concrete. Early morning is recommended.
4. In Tilt-Up applications, the recommended method of formliner attachment is to place the liner on the slab, drill a hole through the liner and into the concrete, place a wooden dowel into the drilled hole, break the dowel off flush with the surface, and then use a large-headed roofing nail to hold the liner in place.
5. Double-sided foam tape may be used for Tilt-Up jobs. Make sure the casting slab and formliner are clean, dry and free of dust.
6. Heavy duct tape can be applied to the formliner at joints on the slab or formwork side. This is the recommended method for pre-assembling large liners for precast or Tilt-Up beds. The liner is assembled upside down and alongside the bed and then rolled into the formwork.
7. Seal all joints and contain liner on all sides so that concrete cannot move under it. Be sure the liner is flat against the casting surface, insuring that no deformations are present in the formliner. Do not allow formliner to move around freely.

Concrete Design

The design of the concrete mix will affect the finished formliner appearance because it causes changes in workability, pressure, color, set and strength.

Load concrete onto the formliner from the centers, moving the concrete towards the outside perimeter with rakes. Do not allow concrete to be pushed under the formliner at joints.

T58 Double Chamfer Strip

Dayton Superior T58 Double Chamfer Strip is an ideal product for use in forming chamfers on both sides of 2x or LSL form lumber. It is an .062 thick extruded PVC (Polyvinyl Chloride) Plastic available in 8ft lengths.

To Order:

Specify: (1) quantity, (2) name, (3) size.

Example:

200 (2,000 linear feet), T58 Double Chamfer Strips, 1-5/8".

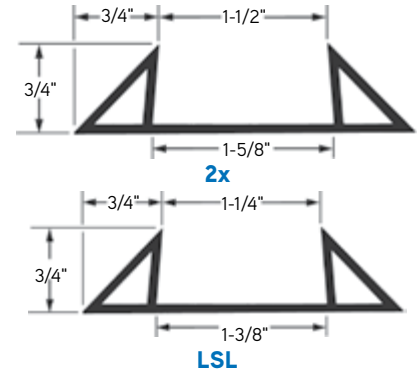

T59 Plastic Keyway

Dayton Superior T59 Plastic Keyway is an extruded plastic keyway for general use on a tilt-up project. Simple to use, just nail to 2x form lumber. Available in 10 ft. lengths.

To Order:

Specify: (1) quantity, (2) name.

Example:

50 (500 linear feet), T59 Plastic Keyway.

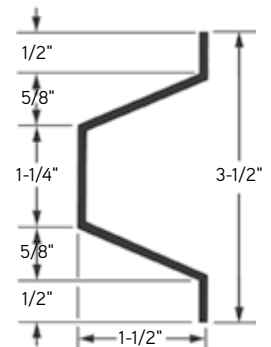

T66 Tilt Bracket™

Tilt-Up Forming System

The Tilt Bracket (US Patent #8186645) consists of lightweight, reusable plastic brackets and an adhesive backed shoe plate. The bracket snaps into the shoe plate that is held firmly to the casting slab by the adhesive base.

Brackets come in two sizes 5" for form height 5" to 7" and 7" for form height 7" to 11". Maximum recommended spacing is 18".

To Order:

Specify: (1) quantity, (2) name, (3) size.

Example:

400, T66 Tilt Brackets™, 7" size.

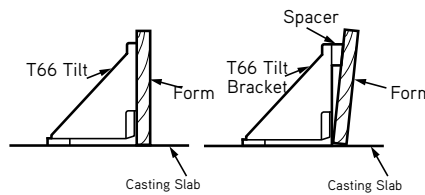

90° Application

Battered Application

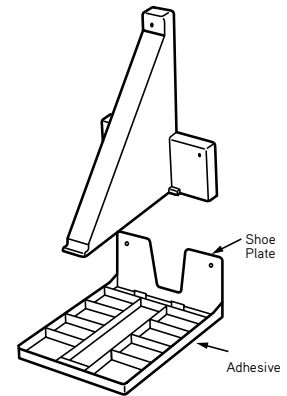

T66 Tilt Bracket
Patent Pending

T29 Superior Panel Base Anchor 10K (PBA 10K)

The Dayton Superior Panel Base Anchor is a quick, discrete and durable system engineered for a permanent connection of concrete panels to footings.

Designed to meet vertical integrity requirements for a nominal tensile strength of 10,000 lbs

Replacement parts available.

To Order:

Specify: (1) quantity, (2) name.

Example:

200, PBA 10K.



PBA 10K

T29 PBA 10K Shear Connector

The shear connector for the Dayton Superior Panel Base Anchor (PBA 10K) provides both in-plane and out-of-plane shear resistance. The system can withstand an ultimate shear load of 15,000 lbs. See the TDS for more information on load capacities and installation.



PBA 10K Shear Connector

To Order:

Specify: (1) quantity, (2) name.

Example:

200, PBA Shear Connectors.

T68 ACA-1000 Construction Spray Adhesive

The Dayton Superior T68 ACA 1000 Construction Spray Adhesive is a fast drying, high strength spray adhesive designed for bonding most construction related materials. T68 spray adhesive is available in 22 oz. cans (sold by the 12 can case).



T68 ACA-1000 Construction Spray Adhesive

To Order:

Specify: (1) quantity, (2) name.

Example:

5 cases, T68 ACA-1000 Construction Spray Adhesive.

GluDown

Dayton Superior offers two GluDown products: Extension Applicator and Upright Spray Can. GluDown Spray Adhesive is a fast drying, high strength spray adhesive designed for bonding most construction related material. Glu-Down Adhesive is used to bond:



- Reveal strips
- Forming brackets
- Chamfers
- Certain types of moisture barriers
- Brick veneer
- Expansion joint materials
- Insulation and block-outs to concrete

T69 T Strip

The Dayton Superior T69 T Strip is a quality strip designed to be inserted into saw cut joints to prevent spalling and to keep the joint free of dirt and debris. T69 T Strips are fabricated in 8' lengths and packaged 125 pieces per box. T69 T Strips can be ordered by the box (125 pieces, 1,000 L.F.) or by total linear feet.



T69 T Strip

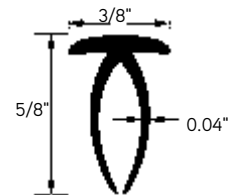

To Order:

Specify: (1) quantity, (2) name.

Example:

500 L.F., T69 T Strip.

T70 EZ Nail Form Bracket

The Dayton Superior T70 EZ Nail Form Bracket is a reusable, inexpensive composite plastic bracket designed for quick and easy fastening of tilt-up panel forms to the casting slab. This unique dual-bracket design provides nail-down installation for 5" through 10" panel form heights.



T70 EZ Nail Form Bracket

To Order:

Specify: (1) quantity, (2) name.

Example:

125 T70 EZ Nail Form Brackets.

Rustications, Chamfers and Other Products

Rustications, chamfers and other products provide innovative solutions to the designer and the contractor. These products provide significant labor savings in the installation of the rustications and chamfers along with eliminating much of the building finish problems which occur with wood products. These products can be found at a Dayton Superior distribution center near you.

V66 Superior Slab Saver

2' PVC Edge pieces installed in the bottom of wall panels used to protect floors during panel erection, eliminating damage to the floor slab during panel erection.

Rustication

3/4" x 45 degree PVC rustication in widths of 2.25", 2.5", 3.5", 5.5", 8.0" and 11.5". These have the patented Flex Edge Seal, insuring a tight joint with the concrete slab and these utilize the Victory Bear Base Clip for easy installation. 1/2" x 60 degree low profile rustication also available.

Snap Rustication

3/4" Triangular PVC rustication which opens to allow easy installation and then snaps shut to prevent concrete seepage.

Bulkhead

3/4" PVC bulkhead chamfer providing chamfer on both sides of the bulkhead. This product is used with both 3/4" plywood and 2x materials. It features both the patented Flex Edge Seal and utilizes the Base Clip to secure the product to the floor slab.

Bullnose

PVC Single Bullnose chamfers provide the radius edges when the designer desires a different effect from the traditional triangular building edges.

Radius Corner

6" PVC Radius Corner provides a distinct radius at a fraction of the cost.

Chamfers

3/4" x 45 degree PVC chamfers in both single and double chamfer versions. This product utilizes the patented Flex Edge Seal and is attached to the floor slab with adhesives or traditional nails or screws.

Chamfers – Low Profile

1/2" x 60 degree PVC chamfers in both single and double chamfer versions. This product utilizes the patented Flex Edge Seal and is attached to the floor slab with adhesives or traditional nails or screws.

Drip Edge Chamfer

3/4" x 45 degree PVC drip edge chamfer for use where doors, windows, dock doors and archways require both a chamfer and drip edge. This product utilizes the patented Flex Edge Seal and is attached to the floor slab with adhesives or traditional nails or screws.

Recessed Window System

A unique utilization of several of the above products with a recessed window chamfer to add a classic detail for doors and windows in the concrete wall panels.

Joint Cover

PVC Joint Covers provide the building owner an attractive cover for the joints inside of the building. Joint Covers will fit into panel joints between 1/4" and 1" gaps.

Saw Cut Cover

PVC Saw Cut Cover temporarily seals the floor slab joints with a unique low profile design.

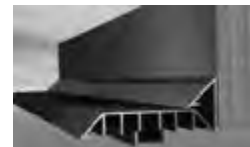

T75 and T75HD Special Drill-in Lift Plate

The Dayton Superior T75 Drill-in Lift Plate is designed and tested for use as an emergency repair lift plate in special situations where a normal cast-in-place tilt-up face pickup insert is missing, tipped over, improperly located or otherwise unusable.

The lift plate is to be installed so that it is centered over the original insert location. When the lift plate cannot be installed at the original insert location, contact Dayton Superior.

When installing the T75 Drill-in Lift plate, always check to make certain the Lifting Lug is aligned in the direction of the cables. DO NOT apply loads at an angle to the flat side of the lifting lug!

The T75 Drill-in Lift Plate is to be attached to the face of the precast concrete tilt-up wall panel using either four or six properly installed Dayton Superior T13 Coil-Anchors, 3/4" diameter x 6" long drill-in expansion anchors or Bearcat™ Bolt. Minimum edge distance from center line of Coil-Anchor bolts is 12". Edge distances of less than 12" may result in a reduced lifting capacity.

To install the T75 Special Drill-in Lift plate, set the plate in its proper position and mark the hole locations. Drill the required number of holes using a new 3/4" diameter carbide tipped drill bit. Depth of drilled holes must be at least 5-1/2" with all holes drilled at 90 degrees to the surface of the panel.

Just before installation of the Coil-Anchor bolts, clean out all of the drilled holes. Failure to properly clean the holes may result in a reduced lift plate load carrying capacity.

Insert the assembled T13 Coil-Anchor bolts through the holes in the lift plate into properly drilled and cleaned holes. Using a hammer, tap the Coil-Anchor bolts all the way into the holes so that the washer and bolt heads come to rest on the top surface of the lift plate.

Tighten the T13 Coil-Anchor bolts using a 3/4" air impact wrench. The bolts must be checked with a torque wrench to make certain that they have been torqued to 200 ft. lb. Use the crane to place a light load onto the lift plate. Release the load and check all bolts to make certain they are still tightened to 200 ft. lb. Bolts torqued to a lower value will have a reduced load carrying capacity.

Do not attempt to pre-expand the Coil-Anchor Tang. For proper load carrying capacity, the Tang must not be installed more than 1-1/2 turns onto the bolt. Do not attempt to use a standard coil bolt with the Coil-Anchor Tang, as this combination will not develop any load carrying capacity. The Coil-Anchor bolt is a special tapered bolt and is not interchangeable with standard coil bolts.

For Bearcat Bolt installation:

1. Drill a 3/4" hole per the setting chart. For use with the T75 and T75HD lift plate, the bearcat bolts must be installed in full embedment. Shallow embedments are not recommended.
2. Thoroughly clean the drilled hole with compressed air or suction to rid the hole of debris.
3. Insert the Bearcat Bolt through the T75 base plate and into the concrete hole. Drive the anchor down until the integrated washer contacts the base plate.
4. Torque to 200 ft. lbs. to complete the install and ensure a secure connection. The base plate should be firmly in place. Be sure not to over-torque the bolt during installation once in contact with the base plate. Excessive torque could damage the connection.

To remove the Bearcat Bolt, simply back the Bearcat Bolt out with a wrench or impact drive.

The safe working loads (SWL) of these drill-in expansion anchors and lift plate are shown below. The safe working loads are determined by the number of T13 expansion anchors actually used to attach the lift plate to the tilt-up panel.

Item	Number of T13 Drill-in Expansion Anchors	Tension or Shear Safe Working Load
T75	4 bolts (2 per each side)	8,500 lbs.
T75	6 bolts (3 per each side)	15,000 lbs.
T75HD	8 bolts (2 per each side)	24,000 lbs.

Note: Insert SWL's are based on approximately a 2 to 1 factor of safety. Lift plate develops approximately a mechanical 5 to 1 factor of safety based on a maximum SWL of 15,000 lb for T75 and 24,000 lb for T75HD. The above SWL's are based on the lifting plate being installed so that the raised lifting lug is aligned with the direction of the lifting cables.

In order to develop the safe working loads of the T75 Special Drill-in Lift Plate, the normal weight concrete in the panel must have attained a minimum compressive strength of 2,500 psi. These safe working loads assume the T13 Coil-Anchor expansion anchors or Bearcat Bolts have been properly installed.

Use only the 6" T13 Coil-Anchor with the T75 Special Drill-In Lift Plate. Do not use the 4-1/2" version.

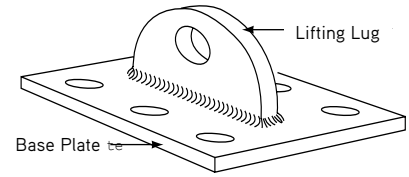

T75 Special Drill-in Lift Plate



T75HD Special Drill-in Lift Plate



T75 Special Drill-in Lift Plate Typical Application

P80 Shim Strips

Dayton Superior P80 Shim Strips assure accurate placing and leveling of tilt-up panels and other architectural and structural components because it:

- is made in convenient thicknesses, lengths and widths allowing precise leveling and alignment.
- permits field changes in load bearing requirements with stock on hand.
- is less expensive and safer than steel. It has extreme stability and eliminates rust, stained concrete and spalling.
- is size scored for convenience of application. Prevents waste — material can be readily picked up and stored in the open for future use.
- will not fracture under load.
- Thicknesses of 1/16", 1/8" and 1/4" in lengths of 3" and 4" are available from stock. The widths of 3" x 24" are scored every 3" and the widths of 4" x 24" are scored every 2". This allows for easy snap off as needed. Additional sizes available on request.
- is impervious to liquids and ground chemicals, alkalis and microorganisms. The continuing performance characteristics are stable and predictable.
- will not rust, rot or leach when exposed to wet surfaces and it has no odor.
- arrives at the job site in precise thicknesses and lengths.
- eliminates the need for saws, hand tools or cutters. A definite saving in time, labor and money is realized. The strips are easily applied and lay flat.
- Point projection of aggregate is absorbed without fracture or effect on the load-bearing characteristics decreasing damage potential to the adjacent concrete components.

Engineering Data: The pertinent physical properties of Dayton Superior plastic shims are presented as follows:

- Compressive strength of 8,000 to 9,000 psi with no fracture even at 26,000 psi.
- Classed as slow burning with no toxic fumes.
- Negligible cold flow characteristics; i.e., less than 1% at 1,000 psi and 73° F. for 10,000 hrs.
- Coefficient of linear expansion is 3 to 5 x 10⁻⁵ inches/inch/°C

To Order:

Specify: (1) quantity, (2) thickness, (3) length, (4) name.

Example:

Example: 300, 1/4" x 4" P80 Shim Strips.

P81 Superior Shimpak

Dayton Superior shimming material is an engineered multipolymer plastic specifically formulated for use by the construction industry.

It is an engineered multipolymer plastic material which provides an optimum combination of physical properties for a shim in applications where high compressive strength and load bearing is important. It facilitates the placement of tilt-up structural and other architectural members.

- These pre-assembled packages of heavy duty shims are designed for large load bearing of precast units.
- Shimpaks are very advantageous in precise placing and leveling of large panels.
- Their use eliminates time consuming correction of elastomeric drift and makes alignment safer and easier.
- Popular sizes are 4" x 6" and 4" x 4" packs which are 1-1/16" thick. Shimpaks are made up of shims in the following thickness sequence; one 1/16th, three 1/4ths and two 1/8ths. Tilt-up panels can be levelled within 1/16" by removing or adding one or more elements.
- Shimpaks are held together with a resilient band for easy removal or addition of elements.
- Alternate sizes available on request.

To Order:

Specify: (1) quantity, (2) size, (3) name.

Example:

Example: 200 packs, 4" x 6" P81 Shimpaks.

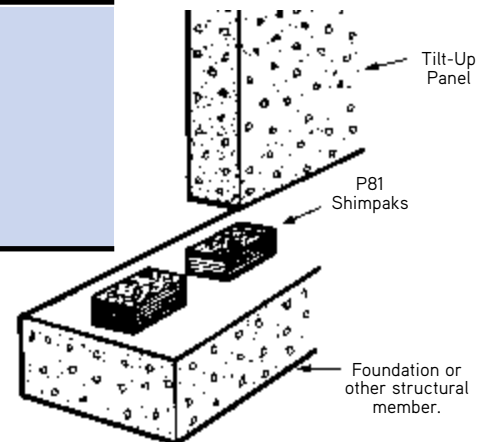

Loop End Wire Ties - WBT

Application: Slab, Side Form Spacer, Tilt-up, Foundations, Precast, D.O.T., and Industry

Features:

- Convenient loop-ends allow for ease of installation
- Used in tying rebar, as bag closures, carpet rolls, etc.
- Other wire gauges and lengths available on an individual inquiry basis
- Epoxy-coated and galvanized wire is available on an individual inquiry basis

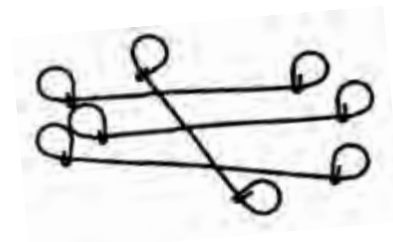

Note: Best used in conjunction with wire tying tools

Aztec® E-Z Chair® - PEZ

APPLICATION:

Single Mat -Rebar or Wire Mesh, Bottom Layer Double Mat Rebar or Wire Mesh, Tilt-Wall, Side-Form Spacer

HEIGHT:

From 3/4" to 6" in 1/4" increments

FEATURES:

- Standard "Concrete Gray" color (custom colors available-inquire)
- Minimal surface contact
- Designed for maximum aggregate flow and concrete consolidation
- High load capacity
- Fits up to #8 rebar



Paragon Mesh Chair

APPLICATION:

Designed to support 6-10 gauge mesh

SIZES:

1", 2", 2.5", 3", 3.5", 4"

FEATURES

- Round base provides stable support on grade
- Snap-in top allows mesh panels to be moved without chairs failing off
- On-grade Paragon products come in various colors



Aztec® Castle Chair™ - PCC

APPLICATION:

On-Grade, Single Mat Rebar or Wire Mesh, Bottom Layer Double Mat Rebar or Wire Mesh, Precast, Tilt-Wall, Insulated "Sandwich" Panels

HEIGHT:

From 1-1/2" to 6-1/4" (1/4" increments)

FEATURES:

- Heavy-duty, stackable design
- Fits up to #8 rebar
- Perfect for use on insulating foam or nonpenetrable vapor barriers
- Most stable on-grade chair available
- Each chair comes in two height combinations reducing inventory

Square Base

Round Base



Aztec® EZ Connect™ PSB

APPLICATION:

Provides a continuous, strong and stable support for spacing rebar in a variety of applications.

HEIGHT:

From 3/4" to 3"

FEATURES:

- EZ Connect end design allows for a fast and secure connection
- Non-corrosive material
- Heights range from 3/4" to 3"
- Available in 2.5', 5' and 10' lengths
- Newly modeled support bed holds rebar in place



Aztec® StrongBack SBU™ Slab Bolster Upper - PSBU

APPLICATION:

Supports top layer in Double Mat application, Rebar or Wire Mesh, Slabs, Heavy Duty On-Grade, Corrugated Decking, Side-Form Spacer-below-grade applications only

HEIGHT:

From 1" to 5" (1/4" increments)

FEATURES:

- Designed for use with Epoxy-Coated/FRP/Stainless Steel/Galvanized rebar
- For use in corrosive environments
- Spans corrugations in elevated deck applications
- Special packaging available in 5' or 10' sections, bundled and palletized
- Suitable for use on Vapor Barriers or Insulating Foam
- No overlap required
- Manufactured in 30" lengths in standard boxes
- Strong as metal SBU



Paragon Test Cylinders

Application:

Test cylinders are used in every application where concrete is used. They are used to test and monitor concrete strength in those applications where minimum strength is required.

Features:

- Reinforced lip and bottom
- Concrete gray color (yellow option on 4"x8" size)

Sizes:

- 2"x4"
- 3"x6"
- 4"x8"
- 6"x12"

To Order:

Specify: (1) quantity, (2) size (3) name.

Example:

80, 3"x6" Paragon Test Cylinders.



Paragon Hole Covers

Application:

Hole-in-one covers adjust to fit various sizes holes in on-grade

Features:

- Prevents accidents and injuries
- Beveled edges prevent tipping hazards
- No sawing, pre-drilling, or bolting into concrete necessary
- Reusable
- Hardware includes

Sizes:

- 15" round
- 7" round
- 15"x15" square
- 8"x15" rectangular

To Order:

Specify: (1) quantity, (2) size (3) name.

Example:

20, 15" round, Paragon Hole Covers.



Kodi Klip® K-Klips

Application:

Use wherever rebar connections are required, specifically on site-pour, precast, tilt-up, concrete applications, pre-stress and pools.

Features:

- Saves time, money and provides stronger rebar connections using the patented four-point grip system that gives more consistent and stable connections
- Dramatically reduces wracking and eliminates unwanted motion
- K-KLIPS are made of high-strength and temperature resistant polycarbonate material
- Works with black, epoxy, stainless, galvanized & composite rebar

Sizes:

- Available in imperial & metric sizes for #3 [6mm] to #6 [20mm] rebar

To Order:

Specify: (1) quantity, (2) metric or imperial (3) part number (4) color.

Example:

1568 pcs., Imperial, # KCS324, Violet.

Within product numbering system, the first Number = TOP rebar size and second number = BOTTOM rebar size. (Imperial - #3 to #4 Rebar, #3 is the top rebar size and #4 is the bottom rebar size)



A95 Dayton Bar

The A95 Dayton Bar is manufactured with a 1" x 2" structural tube handle that has been carefully Mig welded to a heat-treated milled blade. The bar is an ideal tool for use by the tilt-up erector - you will find many uses for it, from adjusting and/or stripping side forms to "jockeying" tilt-up wall panels into position.

Available with either a 3" or 5" wide blade. Please specify blade when ordering.

To Order:

Specify: (1) quantity, (2) name, (3) blade width.

Example:

4, A95 Dayton Bars with 3" blades.

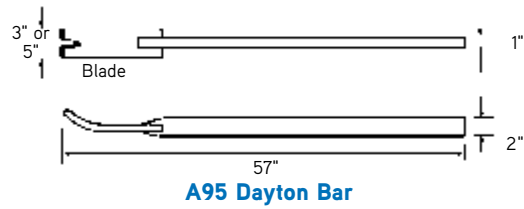

Bar Chair - BC

APPLICATION:

To support wide spaced light steel in slab or deck construction.

Available in plain, galvanized, plastic dip, plastic tip or epoxy coated finish.

HEIGHT:

3/4" to 2", in 1/4" increments

FEATURES:

- Formed cradle to place wire mesh or reinforcing bar.
- Foot designed to set on most forming surfaces.



Individual High Chair - HC

APPLICATION:

To support reinforcing bar or wire mesh during concrete placement in Flat Slab, Tilt Wall Panel, Elevated Slabs, Precast Panels projects, to maintain proper concrete coverage.

HEIGHT:

Available in heights of 2" to 15" in increments of 1/4". Chairs over 12" require cross bracing or lacing of legs.

FEATURES:

- Formed cradle for placing reinforcing bar.
- Designed to resist deformation under construction loading.
- Wide leg span to allow chair to straddle lower bars.
- Foot designed for use on multiple forming surfaces. Plastic Dipped and Plastic Tipped chairs designed for exposed conditions, i.e. Tilt Wall Panels.



Slab Booster - SB

APPLICATION:

To support lower slab steel, on continuous 5ft long top wire.

HEIGHT:

3/4" to 3", in 1/2" increments.

FEATURES:

- Corrugations on top wire are space on 1" centers to serve as guides for spacing reinforcing bars.
- Available in plain, galvanized, plastic dip, plastic tip or epoxy coated finish

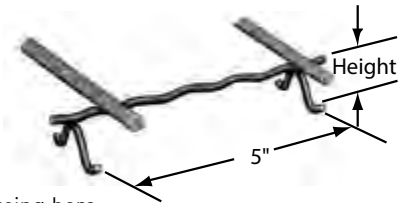

Slab Booster Upper- SBU

APPLICATION:

To support one layer of steel above another and space them to required distance. May also be used to support steel on soft material form surface, such as carton forms or fill material.

HEIGHT:

3/4" to 3", in 1/2" increments.

FEATURES:

- Some sizes are available with corrugated top wire to serve a guide for spacing reinforcing steel.
- Available in plain, galvanized, stainless steel or epoxy coated.
- 5' lengths standard. Other lengths available as special order.



Continuous High Chair - CHC

APPLICATION:

- Support upper slab steel from slab form surface.
- Substitutes for individual chair supports.

NOTE:

Available in 10' lengths on special order basis.

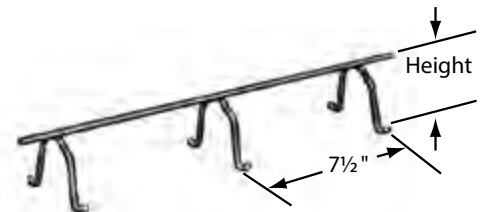

Premium Tie Wire - WTW

APPLICATION:

The WTW Premium Tie Wire is used to create a tie wire connection at rebar intersections.

FEATURES:

- Soft, annealed composition
- Clean, smooth finish
- Square wound



G33 Screed Key Joint

G33 Screed Key Joint is available in heights of 3-1/2", 4-1/2" and 5-1/2" for use in 4", 5" and 6" concrete slabs on grade. Screed key gives a smooth, flush surface joint which requires no filling.

The use of screed key joints minimizes random cracking and provides proper load transfer from slab to slab.

The use of screed key is more economical than simple bulk-headed forms which must be prepared, installed, stripped, cleaned, repaired or replaced and stored. By using screed key, instead of bulk-headed joints, you are able to pour entire slabs or strips at one time. Costly and time-consuming checker boarding is eliminated. you simply install screed key, pour the concrete — finish flush to joint and you are finished.

By using screed key you will have a floor that is ready for covering without any expensive joint filling or treatment, you eliminate any uneven settling and the resulting cost of joint repair and patching. Dayton Superior Screed Key joint saves you money in initial cost, maintenance and upkeep.

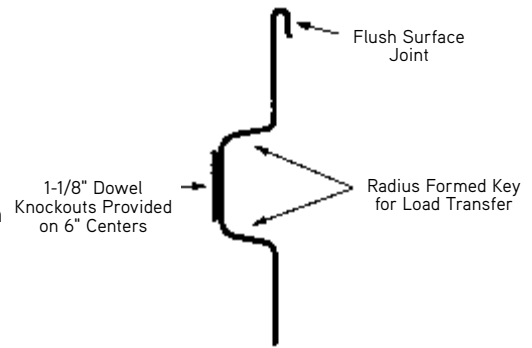

G34 Load Key Joint

G34 Load key Joint is available in heights of 7-1/2" or 9-1/2". It is furnished in 10 foot lengths for use in 8" or 10" slabs and thickened joints. The use of load key allows you to have a floor that is ready to use "as is" or to cover without the expense of costly joint filling.

The use of load key assures you of a strong high quality floor in your new building at a low initial price. It minimizes for years the maintenance cost of joint patching and repair.

Thickened joint slab specifications can be met economically with pre-engineered load transfer by using the easily installed and left in place load key joint.

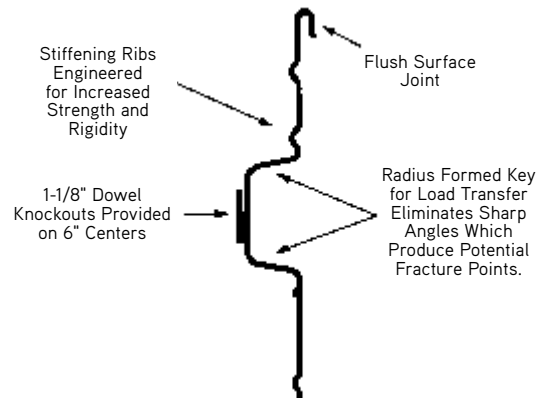

G37 Stake

16 Gauge x 1" wide stake.

Available in 12", 15", 18" or 24" lengths.

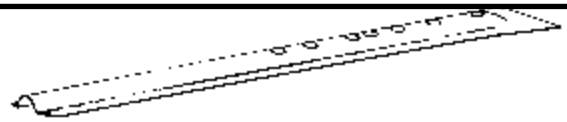

G37 Stake

G38 Plastic Cap Strip

Where joint sealants are specified, plastic cap strip should be used. It is easily removed after the concrete hardens, leaving a wedge shaped joint for easy and economical sealant application.

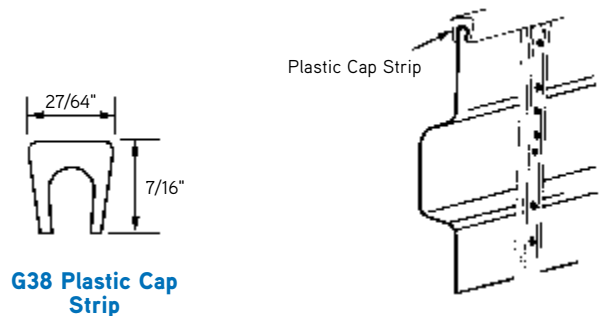

G38 Plastic Cap Strip

Material

Screed Key Joint and Load Key Joint are manufactured from .022" to .025" thick corrosive resistant galvanized steel with 1-1/8" diameter dowel knockouts 6" on center. They are both available in stock lengths of 10 foot. Supporting steel stakes 16 gauge x 1" wide are available in 12", 15", 18" or 24" lengths as required.

Note: Screed Key joint or load key joint is not recommended for use in warehouse floor slabs which are subjected to high volume traffic consisting of fork trucks, heavily loaded hand pallet trucks or heavily loaded steel wheel carts.

Cures and Bondbreakers for Tilt-Up

Cures

Proper, and immediate, curing is vital to the success of a tilt-wall project

1. Timing is more critical on the cure coat than the bondbreaker coat
2. Proper curing will help create a less porous, more dense surface
3. The more dense the surface, the easier the panels will lift
4. For projects requiring an ASTM C-309 cure, use the Dayton System:

Prior to placement of the J6, cure the slab with one of the following:

1. J6 @ 100*-200 Ft²/gal (2.4 - 4.9 M²/L)
2. J22 @ 300-350 Ft²/gal (7.36 - 8.59 M²/L)
3. J23 @ 300-400 Ft²/gal (7.36 - 9.81 M²/L)

Prior to placement of the J6WB, cure the slab with one of the following:

1. J6 @ 100*-200 Ft²/gal (2.4 - 4.9 M²/L)
2. J18 @ 200-300 Ft²/gal (4.9 - 7.36 M²/L)
3. J22 @ 300-350 Ft²/gal (7.36 - 8.59 M²/L)
4. J23 @ 300-400 Ft²/gal (7.36 - 9.81 M²/L)
5. J2W @ 200 Ft²/gal (4.9 M²/L)

* Meets ASTM C 309 moisture retention requirements on a steel troweled surface.

Bondbreakers

A bondbreaker is a material used to prevent adhesion of the newly placed concrete and the substrate*. When a bondbreaker is needed at a construction joint, a curing compound, form release agent and the like can act as a bondbreaker. Bondbreakers used in tilt-wall construction, however, are specifically formulated for that purpose and the chemistry involved with these bondbreakers is different than that of other "bondbreakers".

* ACI116 Cement and Concrete terminology

Dayton Superior Bondbreakers

Sure-Lift (J6) Solvent-based
 Sure-Lift (J6WB) Water-based

Preparation for Applying Bondbreaker

- All surfaces must be clean
- For hot weather precautions, prior to the first bondbreaker application, soak the slab to satisfy its 'thirst' and reduce its porosity; After soaking, squeegee off the excess water then immediately apply the bond breaker. This procedure will help to keep the bondbreaker on the surface, not in the concrete.

Placement of Bondbreaker

- Always read and follow the instructions in the current data sheet
- Apply the bondbreaker evenly, being sure not to leave puddles
- It is best to have several lighter applications than one heavy application

"Good Indications"

Three quick checks that indicate good parting of the panels:

1. Feel a soapy residue on the surface
2. Beading of water
3. Observing an uniform appearance of the bondbreaker

Solvent-Based vs Water-Based

Water has very high surface tension while solvents are low. Surface tension is directly related to wetting and adhesion. Liquids with a high surface tension, like water, are not necessarily as efficient in this respect as the lower surface tension materials like solvents. This is the reason why water-based materials do not lay down as easily as solvent-based materials and why water based are easier to over apply.

Dayton Superior Bondbreaker Comparisons

Condition	J6	J6WB
Shelf Life	12 months	9 months
Mixing	Not required, but good to do occasionally	Agitation required prior to each use
Flammability	High	No
Warehouse storage per Uniform Fire Code	Limited Quantities	Unlimited Quantities
Freezable	No	Yes

BONDBREAKERS

Sure Lift™ with Dye J6D

Solvent Based Bondbreaker

Sure Lift with Dye J6D is a reactive and membrane forming bondbreaker for use in tilt wall construction. Sure Lift with Dye J6D is a special formula of polymers and propriety ingredients designed to provide clean, easy lifting of tilt panels.

Sure Lift™ J6WB

Water Based Bondbreaker

Sure Lift J6WB is a liquid, V.O.C. compliant, water base, reactive and membrane forming bondbreaker for use in tilt wall construction. Sure Lift J6WB is a special formula of polymers and propriety ingredients designed to provide clean, easy lifting of tilt panels.

Maxi Tilt™ with Dye

Water Based Bondbreaker

Maxi Tilt with Dye is a liquid, V.O.C. compliant, water base, reactive and membrane forming bondbreaker for use in tilt wall construction. Maxi Tilt with Dye is a special formula of polymers and propriety ingredients designed to provide clean, easy lifting of tilt panels. Maxi Tilt with Dye has a fugitive dye for ease of visual inspection during application.

CURE & SEAL COMPOUNDS

Cure & Seal LV 25% J20UV

Solvent Based Cure & Seal

Cure & Seal LV 25% J20UV is an acrylic copolymer cure, seal and dustproofing compound in an aromatic solvent containing 25% solids. It is designed for ease of application and better atomization when spraying in a wide temperature range from 35°F to 90°F (2°C to 32°C). Cure & Seal LV 25% J20UV will be ultraviolet stable and resist yellowing. The higher acrylic solids content will form an excellent surface coating with a high gloss finish that provides an outstanding cure performance. Complies with ASTM C-1315.

Cure & Seal 25% J22UV

Solvent Based Cure & Seal

Cure & Seal 25% J22UV is an acrylic copolymer cure, seal and dustproofing compound in an aromatic solvent containing 25% solids with special U.V. stabilizers. The higher acrylic solids content will form an excellent surface coating with a high gloss finish and will provide an outstanding cure performance. Cure & Seal 25% J22UV is ultraviolet light stable and resists yellowing. Complies with ASTM C-1315.

Cure & Seal 309 J18

Water Based Cure & Seal

Cure & Seal 309 J18 is a water based acrylic copolymer that offers a combination curing, sealing and dustproofing for freshly finished concrete surfaces. This product dries to produce a non-yellowing, durable, clear film on concrete. Cure & Seal 309 J18 is ideal for interior applications because it is free of noxious flammable fumes. Complies with ASTM C-309.

DENSIFIERS AND SEALERS

Pentra-Hard® Densifier

Lithium Concrete Hardener for Concrete

Pentra-Hard Densifier is advanced lithium chemistry that hardens and dustproofs new and existing concrete. This easy-to-use water-based solution requires no rinsing and is VOC compliant in all areas of the world. When sprayed on new or existing concrete, it penetrates into the concrete, where it reacts with free calcium to form insoluble calcium silica hydrate, which makes concrete more water, stain, and abrasion resistant for easier maintenance and longer life. It is also suitable for concrete polishing procedures and helps prolong the life of polished finishes.

Pentra-Hard® Guard

High Performance Finish, Stain, Wear Protector

Pentra-Hard Guard is a high performance finish that adds shine, stain resistance and abrasion resistance to concrete. Effective on all concrete and cement containing floors, this water-based, lithium-fortified material cures quickly to form a clear, extremely hard, micro-coating that protects the substrate, even in demanding industrial and commercial environments. This new chemistry makes concrete surfaces more attractive and easier to maintain, and eliminates the need for waxes, polishes, and acrylics.

Sure Hard™ Densifier J17

Liquid Densifier for Concrete

Sure Hard Densifier J17 is a colorless, odorless solution of specialized reactive chemicals that penetrate concrete surfaces to seal, densify and harden the material. Sure Hard Densifier J17 is a water based product and as a result is V.O.C. compliant in every area of the country and environmentally safe to use.

Ultra Seal EF™

Earth Friendly Concrete Sealer

Ultra Seal EF is an Earth Friendly (EF) acrylic, non-yellowing concrete sealer that may contribute to LEED Credits. The formula is low odor and contains VOC < 100 g/L, making it VOC compliant in all areas. It is designed to seal, protect and add an attractive gloss to existing concrete and decorative concrete surfaces. Ultra Seal EF is blush resistant and has good resistance to common chemicals such as motor oil, antifreeze, vinegar and bleach.

EVAPORATION REDUCERS

AquaFilm™ Concentrate J74

Evaporation Retardant

AquaFilm Concentrate J74 is a proprietary emulsion of unique organic compounds designed to minimize moisture loss from fresh concrete. It is economical as a concentrate and is diluted with potable water at a 9 to 1 ratio. As a water based polymer, AquaFilm Concentrate J74 is V.O.C. compliant and contains a blue fugitive dye for ease of visual inspection during application.

AquaFilm™ J74RTU

Evaporation Retardant

AquaFilm J74RTU is a ready-to-use proprietary emulsion of unique organic compounds designed to minimize moisture loss from fresh concrete. As a water based polymer, AquaFilm J74RTU is V.O.C. compliant and contains a yellow fugitive dye.

EPOXY JOINT FILL FOR SAW CUTS

Sure Fil™ J52

Epoxy Joint Filler

Sure Fil J52 is a 100% solids, two component, low shrink, moisture tolerant joint filler and crack repair material.

LATEX BONDING AGENTS / ADMIXTURES

Acrylic Bonding Agent J40

Bonding Agent

A ready-to-use, non-reemulsifiable acrylic admixture and bonding agent designed to improve the adhesion and durability of concrete, masonry, terrazzo and portland cement-sand mixes to horizontal and vertical concrete and other surfaces.

PVA Bonding Agent J41

Bonding Agent

PVA Bonding Agent J41 is a concentrated reemulsifiable/rewettable polyvinyl acetate (PVA) emulsion for use as a bonding agent for application on concrete, cement board or masonry prior to installing patches, mortars, stucco and plaster.

NON-SHRINK GROUT

1107 Advantage Grout™

Cement Based Grout

1107 Advantage Grout is a non-shrink, non-corrosive, non-metallic cementitious grout. 1107 Advantage Grout is designed to provide a controlled, positive expansion to ensure an excellent bearing area. 1107 Advantage Grout can be mixed from a fluid to a stiff plastic consistency.

PANEL SMOOTHING / PREP AND SPRAY ADHESIVE

Architectural Finish™

Rubbing and Sacking Repair Mortar

Architectural Finish is a single component, cement based material specially formulated for rubbing, smoothing, repairing and restoring vertical or overhead concrete surfaces.

Superior Wall Finish

Rubbing, Smoothing & Reprofilng Repair Mortar

Superior Wall Finish is a single component, cement-based trowel, roller or brush applied mortar designed to eliminate small concrete surfaces blemishes, rough areas, bug holes and form marks on poured walls, tilt-up and precast.

GluDown

Spray Adhesive

Dayton Superior offers two GluDown products: Extension Applicator and Upright Spray Can. GluDown Spray Adhesive is a fast drying, high strength spray adhesive designed for bonding most construction related material. Glu-Down Adhesive bonds:

- Reveal strips
- Forming brackets
- Chamfers
- Certain types of moisture barriers
- Brick veneer
- Expansion joint materials
- Insulation and concrete block-outs

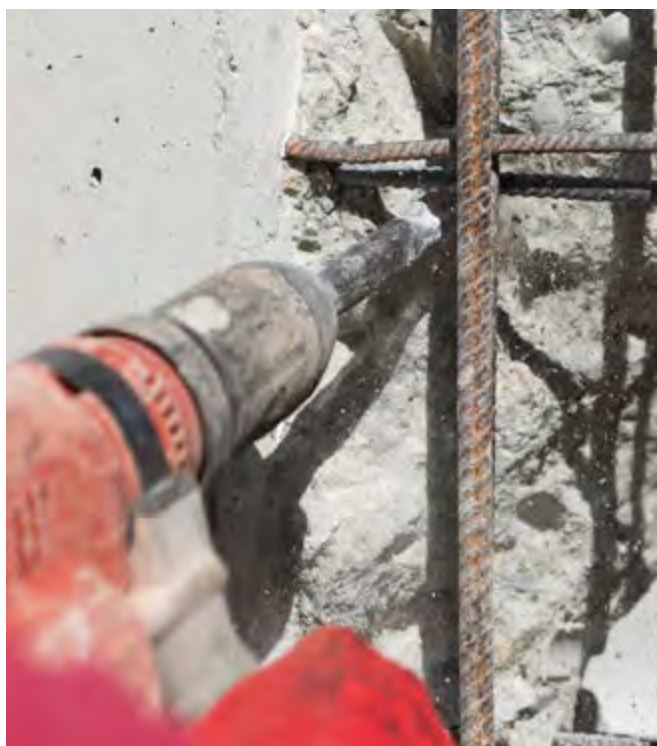

For safety, the tilt-up contractor must perform the following checks to verify dimensions and conditions before casting or erecting panels. The contractor must also consult with the crane contractor to make certain that the crane and rigging is sized properly and that a safe and efficient panel erection sequence is planned and followed.

Check:	Panel Number or Type															
Panel Width and Height																
Panel Opening and Location																
Panel Thickness — Structural and Overall																
Panel Cast Correct Face Up																
Sufficient Bondbreaker Applied																
Reinforcing Size and Location																
Lift Insert Type and Size																
Lift Insert Location																
Brace Anchor Type and Size																
Brace Anchor Location																
Strongback Insert Type and Size																
Strongback Location																
Inserts Correctly Tied in Place																
Exposed Aggregate Size (if used)																
Specified Compressive Strength																
Sufficient Bolt Penetration																
Proper Lifting Hardware																
Cable Lengths and Rigging Configuration																

1107 Advantage Grout	108	Coil Nut	55	Gyro Tilt Plus.....	41
A95 Dayton Bar	103	Coils	52	Gyro Tilt Plus Edge Lift Insert	42
ACA-1000 Construction Spray Adhesive.....	97	Computer Service.....	14	Gyro Tilt Plus Hardware.....	43
Accubrace Total Bracing System	67	Continuous Coil Threaded Rod.....	55	Gyro Tilt Plus Shear Bar	43
Acrylic Bonding Agent.....	108	Corewall Edge and Corner Details	85	Heavy Duty Ground Release II Hardware.....	31
Aluminum Strongback Beams.....	59	Corewall Nut Type Slotted Insert....	82, 83	Heavy Duty Ground Release II Insert....	31
AquaFilm	108	Corewall Slotted Insert II.....	84	Heavy Duty Gyro Tilt Plus Hardware ...	43
AquaFilm Concentrate.....	108	Corewall Slotted Insert II - Edge and		Heavy Duty Gyro Tilt Plus Insert	43
Architectural Finish.....	108	Corner Detail.....	85	Heavy Duty Long Pipe Brace	64
Aztec Castle Chair	101	Corewall Slotted Strap Anchor	83	Heavy Duty Regular Pipe Brace.....	64
Aztec EZ Chair Chair	101	Corewall Strap Anchor.....	83	Heavy Nut.....	55
Aztec EZ Connect.....	101	Corewall Strap Type Slotted Insert	85, 83	Helical Ground Anchors.....	68
Aztec Strongback	101	Corewall Threaded Strap Anchor	83	HGA	68
B1A.....	64	Corner Bracing	66	HGA Extensions	68
B4	64	Crane	16	HGA Installation.....	69
B5	64	Cures	107	History.....	1
B7	64	Cure & Seal 25%.....	107	Paragon Hole Covers	102
B8	64	Cure & Seal 309.....	107	Insert Locator Plugs.....	47
B9	64	Cure & Seal LV 25%.....	107	Inverted Wall Brace Anchor	74
B10	64	D410.....	87	J6D.....	107
B11	55	D487	88	J6WB.....	107
B12	64	D490	88	J17	107
B13.....	55	D491	88	J18	107
B14	53, 64	D492	88	J20UV	107
B15.....	64	D493	88	J22UV	107
B16.....	64	Dayton Bar	103	J40.....	108
B17A.....	64	Delta Tie.....	76, 78	J41.....	108
B18.....	64	Densifiers.....	107	J52.....	108
B25.....	55	Distances.....	8	J74.....	108
Bearcat Bolt Multi-Use	70	Double Chamfer Strip.....	96	J74RTU	108
Bearcat Bolt Single Use	70	Double Ground Release II System.....	30	Joint Cover.....	98
Bolt Length.....	52	Double Pick-Up Insert	48	Jumbo Pipe Braces	64
Bondbreakers.....	106, 107	Double Swivel Lifting Plate	54	K-Klips	102
Boom Positioning.....	17	Drill-in Lift Plate	99	Keyway.....	105
Brace Anchor	74	Drip Edge Chamfer	98	Kodi Klip.....	102
Brace Anchor for Fill.....	73	Dry Film Lubricant.....	71	Lifting Angle	54
Brace and Re-Rig.....	18	Edge Inserts.....	51	Lifting Eye	39
Brace Length.....	65	Edge Lift Application	26	Lift Precautions	12
Brace Maintenance.....	66	Edge Lifting Plate	54	Lightweight Concrete.....	4
Brace Removal.....	62	EPOXY JOINT FILL.....	108	Load Key Joint.....	105
Braces	68	Erection Details	13	Loop End Wire Ties	100
Brace Safe Working Loads.....	63	EVAPORATION REDUCERS.....	108	Maxi Tilt with Dye	106
Brace to Floor Slabs.....	63	EZ Nail Form Bracket	97	Minimum Coil Penetration	53
Brace-to-Wall Connection.....	68	Failure	6	Non-Shrink Grout.....	108
Brace Wind Loading.....	61	Flat Washer	55	P24.....	76
Bracing.....	18	Fleet Patch.....	21	P27.....	79
Bulkhead.....	98	Foam Panel Insulation	77	P30.....	82
Bullnose.....	98	Formliners.....	89	P31.....	82
Capacity	5	G33.....	103	P32.....	83
Cast-In-Place Brace Anchor Loading...	74	G34.....	103	P33.....	83
Chamfers.....	98	G37.....	103	P34.....	83
Chamfers - Low Profile.....	98	GluDown.....	97, 108	P37.....	81
Checklist.....	109	Ground Release II Lifting Hardware.....	28	P38.....	84
Coatings.....	107, 108	Ground Release II Patch Cap	30	P51SL	39
Coil-Anchor.....	72, 73	Ground Release II Spreader Beam.....	30	P52.....	33
Coil Bolts	53	Ground Release II System	27	P53.....	37

P54.....	33	Square Braces.....	65	T21.....	47
P59.....	33	Stake.....	105	T26.....	54
P60.....	38	Standard Rigging.....	16	T27.....	54
P80.....	100	STBC.....	68	T28.....	75
P81.....	100	Strongback Assemblies.....	59	T29.....	96
P99P.....	21	Strongbacks.....	57	T41.....	27
Panel Analysis.....	12	Strongback-Shore.....	57	T42.....	30
Panel Base Anchor.....	96	Superior 5-8.....	64	T43L.....	28
Panel Checklist.....	109	Superior 8-14.....	64	T45.....	30
Panel Smoothing / Prep.....	107	Superior 14-23.....	64	T46HD.....	30
Paragon Products.....	101, 102	Superior 22-30.....	64	T49E.....	42
PBA 10K.....	96	Superior 17.....	64	T50.....	43
PBA 10K Shear Connector.....	97	Superior 22.....	64	T51.....	43
PCC.....	101	Superior 22+5.....	64	T52.....	43
Pentra-Hard Densifier.....	107	Superior 32.....	64	T53.....	43
Pentra-Hard Guard.....	107	Superior 33 HD.....	64	T58.....	96
PEZ.....	101	Superior 32+5.....	64	T59.....	96
Pipe Brace Extensions.....	64	Superior 32+10.....	64	T63.....	59
Plastic Keyway.....	96	Superior 32+10+10.....	64	T63S.....	59
Plumbing.....	17	Superior 42.....	64	T66.....	96
Plumbing Precautions.....	17	Superior 52.....	64	T68.....	97
PSB.....	101	Superior 62.....	64	T69.....	97
PSBU.....	101	Superior Lift Hardware.....	23	T70.....	97
PSC.....	101	Superior Lift System.....	20	T75.....	99
PVA Bonding Agent.....	108	Superior Plate Dowel.....	75	T75HD.....	99
Radius Corner.....	98	Superior Shimpak.....	100	T81.....	31
Recessed Window System.....	98	Superior Slab Saver.....	98	T83.....	31
Rigging.....	16	Superior Wall Finish.....	108	T110.....	20
Rustications.....	98	Sure Fil.....	108	T110E.....	26
Safety.....	3	Sure Hard Densifier.....	107	T120.....	23
Safe Working Loads.....	3	Sure Lift.....	107	T275.....	21
Sandwich Panel Connectors.....	76	Sure Lift with Dye.....	107	Tang Bolt.....	68
Saw Cut Cover.....	98	Swift Lift Anchor.....	33	Technical Assistance.....	2
SBU.....	104	Swift Lift Eye Anchor.....	37	Test Cylinders (Paragon).....	102
Screed Key Joint.....	105	Swift Lift Recess Plug.....	33	Thermoform Formliners.....	89
Sealers.....	107	Swift Lift Shear Bar.....	33	Thread Gauge.....	73
Set-Eez Dry Film Lubricant.....	72	Swift Lift Tension Bar.....	38	Tie Wire.....	104
Shimpak.....	100	Swivel Lift Plate.....	54	Tilt Bracket.....	96
Shim Strips.....	100	T1.....	47	Tilt-Up Anchor.....	22
Short Pipe Brace.....	65	T2.....	48	Tilt-Up Chair (Paragon).....	101
Single-Hole Wall and Floor Plate Bracket.....	68	T3.....	51	Tilt-Up Wall Braces.....	64
Single Pick-Up Insert.....	47	T3A.....	51	Transfer Method.....	18
Slab Bolster.....	104	T4.....	73	Transitional Brace Connector Installation.....	68
Slab Bolster Upper.....	104	T5A.....	74	Transition Brace Connector.....	68
Sleeve-Lock 3/4" SCH40 PVC.....	88	T5A Stick On Foam Dot Indicator.....	74	T Strip.....	97
Sleeve-Lock Form Plug.....	88	T6A-Heavy.....	75	Two-Hole Wall & Floor Plate Bracket.....	68
Sleeve-Lock Grout.....	87	T7S.....	48	Ultra Seal EF.....	107
Sleeve-Lock Grout Sleeve.....	87	T7ST.....	48	V66.....	98
Sleeve-Lock Port Plug.....	88	T8.....	54	WBT.....	100
Sleeve-Lock Seal Plug.....	88	T12.....	54	Wind Loading.....	61
Slotted Setting Plugs.....	48	T13.....	72, 73	Wire Ties.....	100
Snap Rustication.....	98	T13G.....	72	WTW.....	104
Special Drill-in Lift Plate.....	99	T13L.....	721	Yeti-Anchor.....	79
Splice Plate for T63 Beams.....	59	T14.....	64		
Spray Adhesive.....	97, 108	T15.....	64		

	<p style="text-align: center;"> WARNING</p> <p style="text-align: center;">Improper Use of Concrete Accessories Can Cause Severe Injury or Death</p> <p>Read, understand and follow the information and instructions in this publication before using any of the Dayton Superior concrete accessories displayed herein. When in doubt about the proper use or installation of any Dayton Superior concrete accessory, immediately contact the nearest Dayton Superior Service Center or Technical Service Department for clarification.</p>
---	--

Dayton Superior products are intended for use by trained, qualified and experienced workers only. Misuse or lack of supervision and/or inspection can contribute to serious accidents or deaths. Any application other than those shown in this publication should be carefully tested before use.

The user of Dayton Superior products must evaluate the product application, determine the safe working load and control all field conditions to prevent applications of loads in excess of a product's safe working load. Safety factors shown in this publication are approximate minimum values. The data used to develop safe working loads for products displayed in this publication are a combination of actual testing and/or other industry sources. Recommended safe working loads given for the products in this publication must never be exceeded.

Worn Working Parts

For safety, concrete accessories must be properly used and maintained. Concrete accessories shown in this publication may be subject to wear, overloading, corrosion, deformation, intentional alteration and other factors that may affect the device's performance. All reusable accessories must be inspected regularly by the user to determine if they may be used at the rated safe working load or should be removed from service. The frequency of inspections depends upon factors such as (but not limited to) the amount of use, period of service and environment. It is the responsibility of the user to schedule accessory hardware inspections for wear and remove the hardware from service when wear is noted.

Shop or Field Modification

Welding can compromise a product's safe working load value and cause hazardous situations. Knowledge of materials, heat treating and welding procedures is necessary for proper welding. Consult a local welding supply dealer for assistance in determining required welding procedures.

Since Dayton Superior cannot control workmanship or conditions in which modifications are done, Dayton Superior cannot be responsible for any product altered in the field.

Interchangeability

Many concrete accessory products that Dayton Superior manufactures are designed as part of a system. Dayton Superior strongly discourages efforts to interchange products supplied by other manufacturers with components supplied by Dayton Superior. When used properly, and in accordance with published instructions, Dayton Superior products have proven to be among the best designed and safest in the industry. Used improperly or with incompatible components supplied by other manufacturers, Dayton Superior products or systems may be rendered unsafe.

Installation

WARNING

1. Dayton Superior Corporation products shall be installed and used only as indicated on the Dayton Superior Corporation installation guidelines and training materials.
2. Dayton Superior Corporation products must never be used for a purpose other than the purpose for which they were designed or in a manner that exceeds specific load ratings.
3. All instructions are to be completely followed to ensure proper and safe installation and performance
4. Any improper misuse, misapplication, installation, or other failure to follow Dayton Superior Corporation's instruction may cause product malfunction, property damage, serious bodily injury and death.

THE CUSTOMER IS RESPONSIBLE FOR THE FOLLOWING:

1. Conformance to all governing codes
2. Use of appropriate industry standard hardware
3. The integrity of structures to which the products are attached, including their capability to safely accept the loads imposed, as evaluated by a qualified engineer.

SAFETY INSTRUCTIONS:

All governing codes and regulations and those required by the job site must be observed. Always use appropriate safety equipment.

Design Changes

Dayton Superior reserves the right to change product designs, rated loads and product dimensions at any time without prior notice.

Note: See Safety Notes and Safety Factor Information.



DAYTON[®]
SUPERIOR

1125 Byers Road
Miamisburg, OH 45342
937-866-0711
888-977-9600

BUILDING[™]
STRENGTH

DS2

REV. 03/24

Copyright © 2016 Dayton Superior Corporation, All Rights Reserved.