

ORIGINAL SIZE OF THIS DRAWING IS 22" x 34"

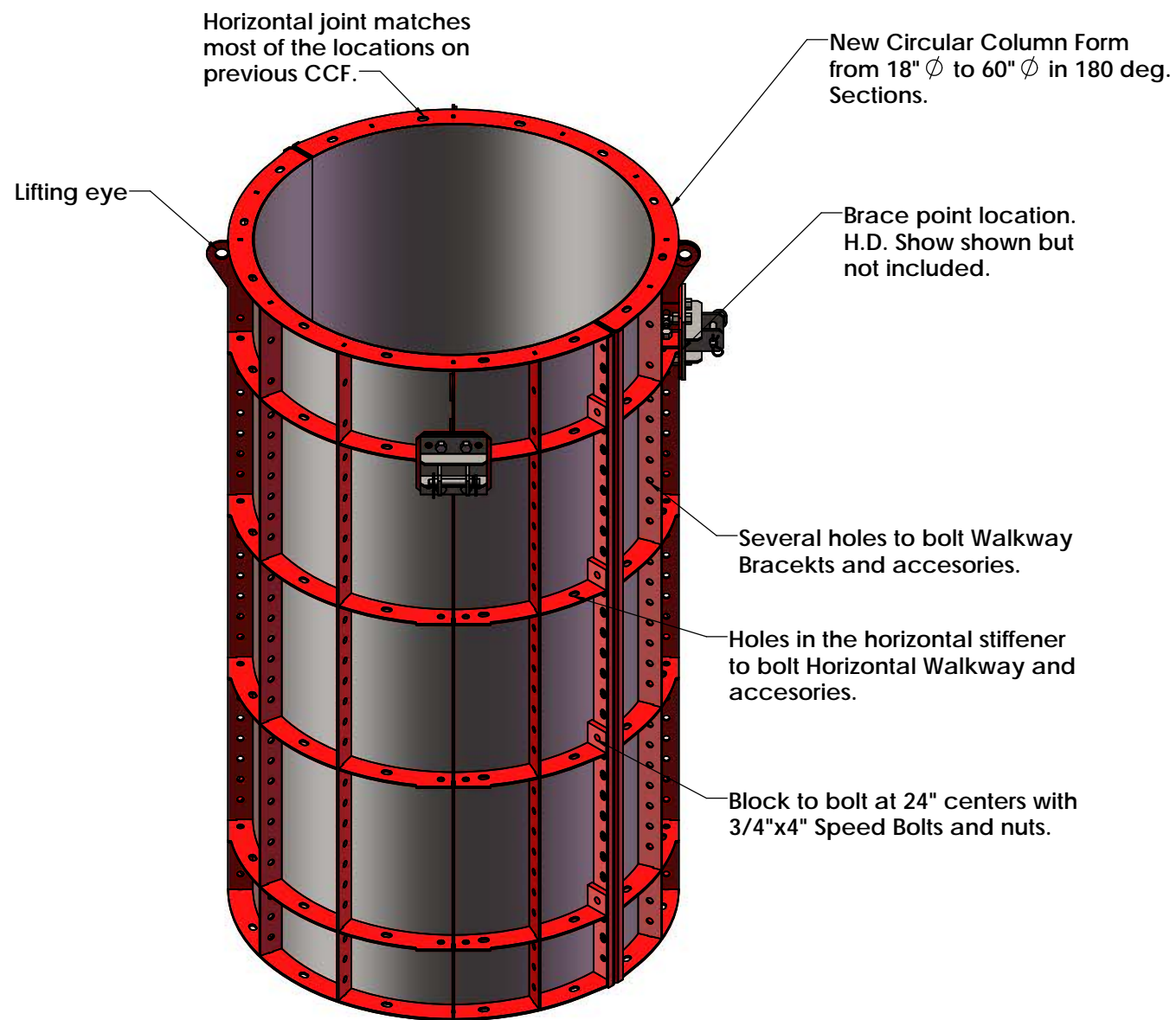

**New Circular Column Form in 180 Deg.**  
**Sections from 18"  $\phi$  to 60"  $\phi$  CCF.**  
**Allowable Pour Pressure is 3,000 psf.**

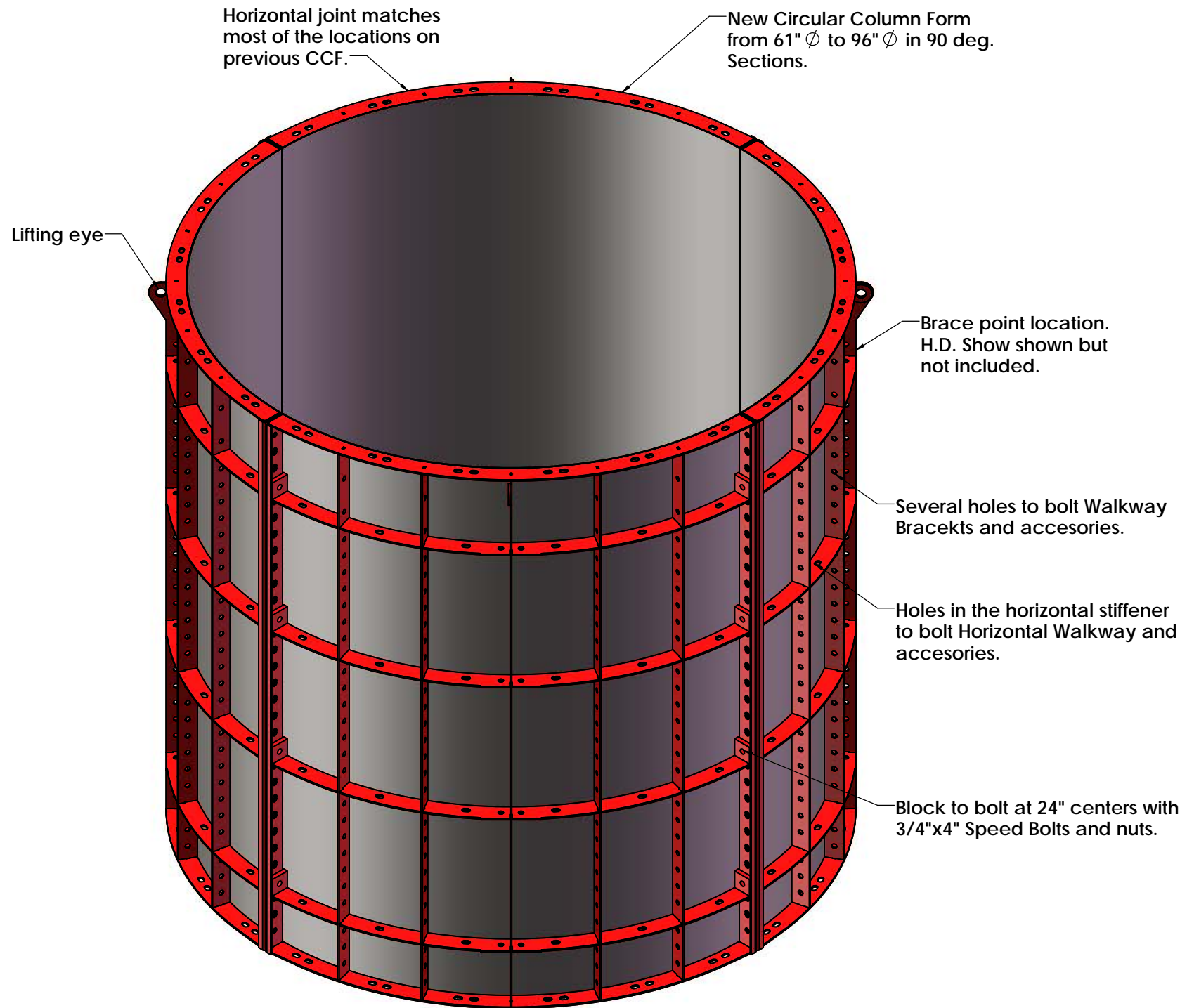

**New Circular Column Form in 90 Deg.**  
**Sections from 61"  $\phi$  to 96"  $\phi$  CCF.**  
**Allowable Pour Pressure is 2,000 psf.**

REVISIONS				
#	DESCRIPTION	BY	CHK'D	DATE

THIS DRAWING SHALL BE USED IN CONJUNCTION WITH THE COVER SHEET, SAFETY & APPLICATION SHEET, AND INDUSTRY STANDARDS. PLEASE REFER TO ALL RELATED MATERIAL AND CONTACT SYMONS BY DAYTON SUPERIOR FOR ANY QUESTIONS IF UNSURE OF PROPER PROCEDURES AND/OR USE.

**SYMONS**  
 BY DAYTON SUPERIOR

125 BYERS ROAD  
 MIAMISBURG, OH 45342

For Customer Service or Technical Assistance call your representative or: 1-800-800-7966



THESE DRAWINGS ARE BASED ON THE FOLLOWING CUSTOMER PROVIDED DRAWINGS:

ENG/ARCH FIRM CONTRACT DRAWINGS	N/A
DRAWING NUMBER(S)	N/A
REVISION	DATE

CUSTOMER	N/A	
LOCATION	N/A	
DRAWN	HAO	DATE 7.9.2021
CHECKED	DATE	

JOB NAME	N/A		
JOB PHASE	N/A		
DRAWING SUBJECT	BRACE BRACKET CONNECTION		
ACCT MANAGER	EPDb #	SHEET #	
N/A	N/A	TCFA-01	

DRAWING FILE PATH

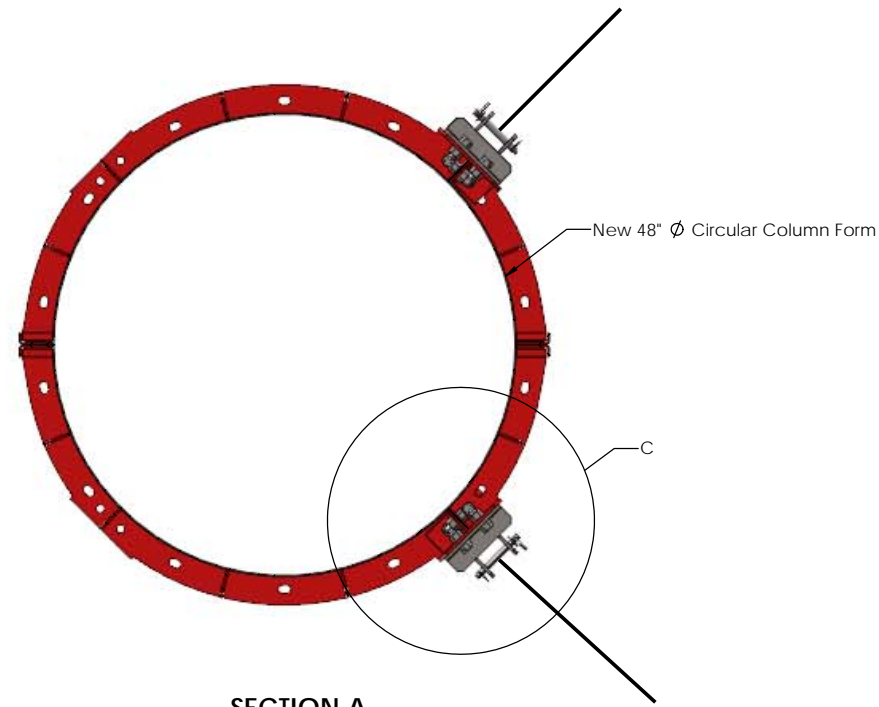

**SECTION A**

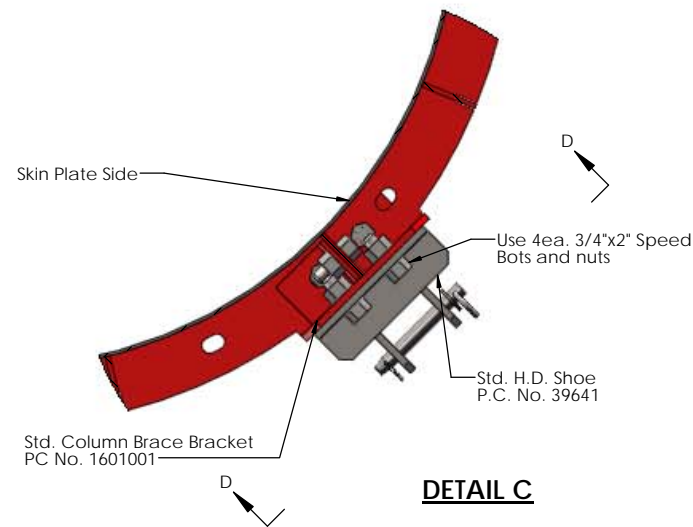

**DETAIL C**

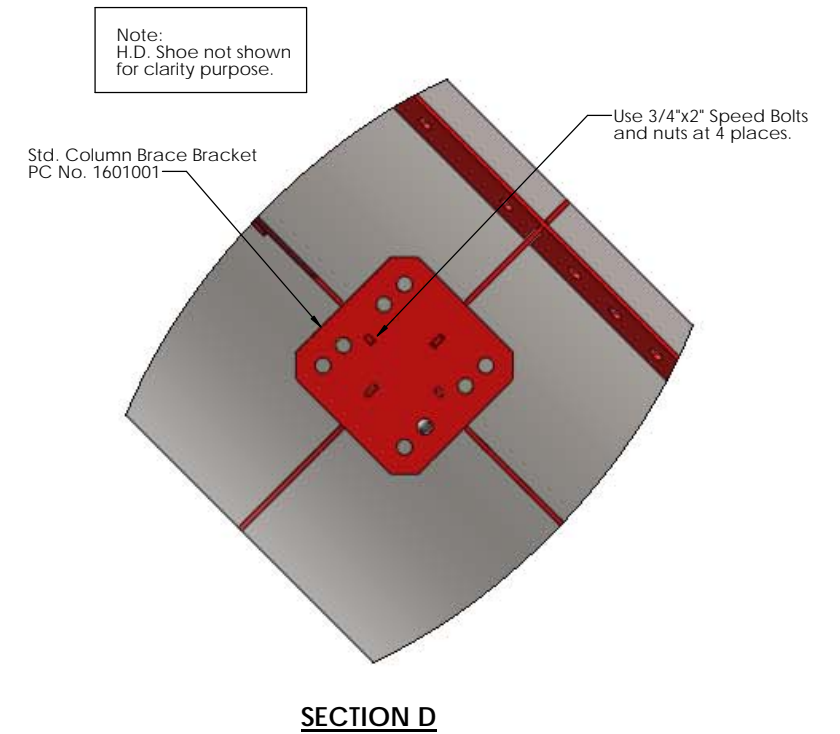

**SECTION D**

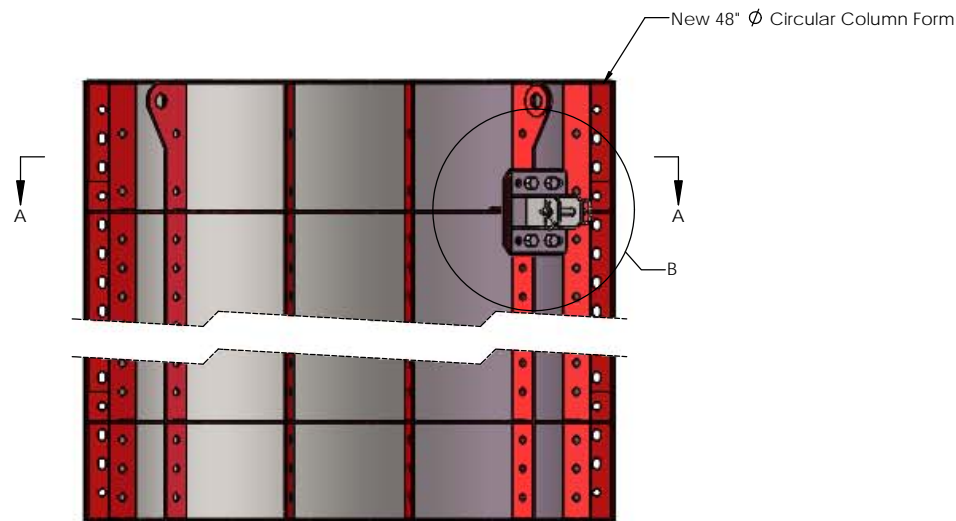

**101 - ELEVATION**

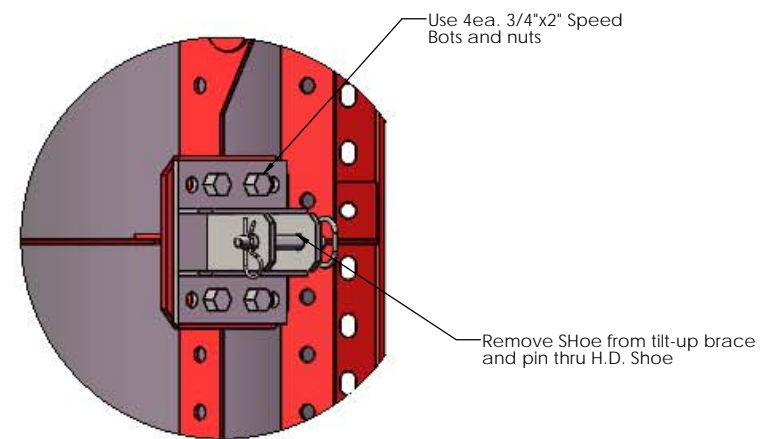

**DETAIL B**

REVISIONS

#	DESCRIPTION	BY	CHK'D	DATE
△				
△				
△				
△				

**-PRELIMINARY-  
NOT FOR CONSTRUCTION**

THIS DRAWING SHALL BE USED IN CONJUNCTION WITH THE COVER SHEET, SAFETY & APPLICATION SHEET, AND INDUSTRY STANDARDS. PLEASE REFER TO ALL RELATED MATERIAL AND CONTACT SYMONS BY DAYTON SUPERIOR FOR ANY QUESTIONS IF UNSURE OF PROPER PROCEDURES AND/OR USE.



125 BYERS ROAD  
MIAMISBURG, OH 45342  
For Customer Service or Technical Assistance call your representative or: 1-800-800-7966



THESE DRAWINGS ARE BASED ON THE FOLLOWING CUSTOMER PROVIDED DRAWINGS:

ENG/ARCH FIRM CONTRACT DRAWINGS	N/A
DRAWING NUMBER(S)	N/A
REVISION	DATE

CUSTOMER

N/A
LOCATION
N/A
DRAWN
HAO
CHECKED

DATE

7.9.2021
DATE

JOB NAME

N/A
JOB PHASE
N/A
DRAWING SUBJECT
BRACE BRACKET CONNECTION
ACCT MANAGER
N/A
EPDb #
N/A
SHEET #
TCFA-02