



DAYTON SUPERIOR CORPORATION
1125 Byers Road
Miamisburg, OH 45342
800-745-3700
www.daytonsuperior.com

MECHANICAL SPLICE SYSTEMS FOR STEEL REINFORCING BARS:

- **BAR-LOCK**
- **TAPER-LOCK**
- **DB/DI**

CSI Section:
03 21 00 Reinforcing Steel

1.0 RECOGNITION

The Dayton Superior Mechanical Splice Systems recognized in this report have been evaluated for use as mechanical splices for deformed steel reinforcing bars (rebar) in concrete structural members. The structural properties of the Mechanical Splice Systems comply with the intent of the provisions of the following codes and regulations:

- 2021, 2018, 2015, 2012, and 2009 International Building Code® (IBC)
- 2021, 2018, 2015, 2012, and 2009 International Residential Code® (IRC)
- 2023 City of Los Angeles Building Code (LABC) – attached Supplement
- 2023 City of Los Angeles Residential Code (LARC) – attached Supplement

2.0 LIMITATIONS

Use of the Dayton Superior Mechanical Splice Systems recognized in this report is subject to the following limitations:

2.1 The couplers shall be installed in accordance with the applicable code, the manufacturer's instructions, and this report. In the event of a conflict, the more restrictive governs.

2.2 Splice locations and rebar placement shall comply with applicable code requirements and be noted on plans approved by the building official.

2.3 Under the 2021 IBC or IRC, mechanical splice systems used in special moment frames (SMF), SMF constructed of precast concrete, special structural walls, intermediate structural wall connections, and other applicable structures are only allowed as permitted in Chapter 18 of ACI 318-19, and as described in Sections 2.3 to 2.7 of this report.

2.4 Under the 2021 IBC or IRC, only Type 2 mechanical splices of ASTM A706 Grade 60 reinforcement or ASTM A615 Grade 60 reinforcement satisfying the requirements of ACI 318-19 Section 20.2.2.5(b), shall be permitted in regions where plastic hinging may occur, and located within a distance equal to twice the member depth from the column or beam face for special moment frames or from critical sections where yielding of the rebar occurs as a result of lateral displacements beyond the linear range of behavior in accordance with ACI 318-19 18.2.7.2. It is unknown if mechanical splices of other grades of steel reinforcement in special moment frames and special structural walls are capable of resisting stress levels expected in yielding regions in accordance with ACI 318-19 R18.2.7, and this use is beyond the scope of this report.

2.5 Under the 2021 IBC or IRC, the ability of the included mechanical splice systems, when used on Grade 80 reinforcement, to resist forces and provide yielding in the vicinity of the intermediate precast structural wall connections between precast wall panels, or between wall panels and the foundation, in the plastic region in accordance with ACI 318-19 R18.5, has not been determined, and this use is beyond the scope of this report.

2.6 Under the IBC or IRC, mechanical splice systems used in special moment frames constructed using precast concrete are expected to experience flexural yielding in connection regions in accordance with ACI 318-19 and -14 R18.9 (ACI 318-11 and -08 R21.8), and this use is beyond the scope of this report.

2.7 Under the 2021 IBC or IRC, mechanical splices of Grade 80 reinforcement shall not be used to transfer forces between the diaphragm and the vertical elements of the seismic-force-resisting system in accordance with ACI 318-19 18.12.7.4.

2.8 Under the 2021, 2018, and 2015 IBC or IRC, deformed steel reinforcing bars used with the Dayton Superior Mechanical Splice Systems shall comply with ACI 318-19 and -14, as applicable, Section 20.2.2.4 and Table 20.2.2.4(a) for the intended structural usage and application.

2.9 Under the 2021 IBC or IBC, for structures regulated by Chapter 18 of ACI 318-19 (as required by 2021 IBC Section 1905.1), to splice deformed steel reinforcing bars resisting earthquake-induced moment, axial force, or both, in special seismic systems and anchor reinforcement in Seismic Design Categories (SDC) C, D, E, and F, with the Dayton Superior Mechanical Splice Systems, mill certificates of the steel reinforcing bars shall be submitted to the building official as evidence of compliance with ACI 318-19 Section 20.2.2.5.

2.10 For structures regulated by ACI 318-14 Chapter 18 and ACI 318-11 and -08 Chapter 21, as required by the 2018,

The product described in this Uniform Evaluation Service (UES) Report has been evaluated as an alternative material, design or method of construction in order to satisfy and comply with the intent of the provision of the code, as noted in this report, and for at least equivalence to that prescribed in the code in quality, strength, effectiveness, fire resistance, durability and safety, as applicable, in accordance with IBC Section 104.11. This document shall only be reproduced in its entirety.





2015, and 2012 IBC Section 1905.1 (2009 IBC Section 1908.1), to splice deformed reinforcing bars to resist earthquake-induced flexure, axial force, or both, in special moment frames, special structural walls, and all components of special structural walls including coupling beams and wall piers, with the mechanical splice systems, mill certificates of reinforcing bars shall be submitted to the building official as evidence that the steel reinforcing bars comply with ACI 318-14 Section 20.2.2.5 (ACI 318-11 and -08 with Section 21.1.5.2).

2.11 Special inspections shall be provided in accordance with Section 3.4 of this report.

2.12 Minimum concrete cover shall be in accordance with ACI 318-19 Section 20.5.1 (2021 IBC), ACI 318-14 Section 20.6.1 (2018 and 2015 IBC), or ACI 318-11 and -08 Section 7.7 (2012 and 2009 IBC, respectively), as referenced by IBC Section 1808.8.2. The concrete cover shall be measured from the outer surface of the splice system.

2.13 The threaded end of reinforcing bars used with the Taper-Lock Reinforcing Bar Mechanical Splice Couplers shall be fabricated according to the specifications provided by the manufacturer. The fabricator shall conform to the following requirements:

1. The fabricator shall be approved by the building official in accordance with 2021, 2018, and 2015 IBC Section 1704.2.5.1 (2012 IBC Section 1704.2.5.2 or 2009 IBC Section 1704.2.2).

2. The fabricator shall be approved by the manufacturer.

3. The fabricator shall demonstrate the following items to the satisfaction of the building official for each coupler model type and steel reinforcing bar size:

a. The fabricator prepares the ends of the steel reinforcing bar as required by Dayton Superior in a manner consistent with the treatment of the qualifying test specimens.

b. For Type 2 splices, splices of each steel reinforcing bar using the fabricator-prepared steel reinforcing bars, tested in static tension, shall develop at least 100 percent of the specified tensile strength of the steel reinforcing bar and at least 125 percent of the specified yield strength of the reinforcing bar. Evidence of compliance may be demonstrated by test reports submitted to the building official.

c. For Type 1 splices, splices of each steel reinforcing bar using fabricator-prepared steel reinforcing bars, tested in static tension, shall develop at least 125 percent of the specified yield strength of the steel reinforcing bars. This may be demonstrated by test reports submitted to the building official for approval.

2.14 The Taper-Lock Reinforcing Bar Mechanical Splice Couplers may be used on epoxy-coated reinforcing bars as long as the coating process is conducted prior to rebar threading. All threads of the coupler and reinforcing bar are to be free of all debris, including epoxy coating, at the time of splicing.

2.15 Minimum spacing of DB/DI (as described in Section 3.3.3 of this report) shall be in accordance with ACI 318-19 and -14 Section 25.6.1.1 as referenced by the 2021, 2018, and 2015 IBC (ACI 318-11 Section 7.6 as referenced by the 2012 IBC and 2009 IBC Section 1907.6).

2.16 If bending of the reinforcing bar is necessary before attachment to the splice system, the bar shall be cold bent as set forth in Section 26.6.3.2(a) of ACI 318-19, for the 2021 IBC, Section 26.6.3.1(a) of ACI 318-14 for the 2018 and 2015 IBC (Section 7.3.1 of ACI 318-11 and -08 for the 2012 and 2009 IBC, respectively).

2.17 The Dayton Superior Mechanical Splice Systems are produced in Tremont, PA; Rushsylvania, OH; Modesto, CA; Detroit, MI; Hastings, PA; and Jiangsu, China.

3.0 PRODUCT USE

3.1 General: The Dayton Superior Mechanical Splice Systems are used to mechanically splice deformed steel reinforcing bars (rebar) installed in concrete structural members. The splices conform to ACI 318-19 and -14 Section 25.5.7.1 and Section 18.2.7.1 (ACI 318-11 Sections 12.14.3.2 and 21.1.6), referenced in Section 1901.2 of the IBC as tension and compression mechanical splices for deformed steel reinforcing bars. The couplers comply with the requirements of ACI 318-19 and -14 Section 18.2.7.1 for the 2021, 2018, and 2015 IBC; ACI 318-11 Section 21.1.6.1 for the 2012 IBC; and ACI 318-08 for the 2009 IBC, as Type 1 or Type 2 mechanical splices. When used as Type 2 splices for Grade 60 reinforcement, the recognized splice systems are permitted within the concrete structural member, as allowed by the IBC, IRC, and ACI 318, for all seismic design categories.

3.2 Design: Splice Systems shall be installed in accordance with the IBC, ACI 318, this evaluation report, and the manufacturer's installation instructions. Where conflicts occur, the more restrictive shall govern. The locations of splices shall be detailed on the plans and approved by the building official. Concrete cover and spacing shall be as required in IBC Chapters 7 and 19, ACI 318-19 Section 20.5.1, ACI 318-14 Section 20.6.1 (ACI 318-11 and -08 Section 7.7), and shall be measured from the outer surface of the splice system or as defined by the registered design professional. Under the 2021 IBC and IRC, the use of the Dayton Superior Mechanical Splice Systems in members and structural systems is limited to what is allowed in Section 18.2.7.2 of ACI 318-19.

3.3 Installation: The manufacturer's installation instructions for Bar-Lock, Taper-Lock, and DB/DI splicing systems, dated 03/17, are available through the following link: <http://www.daytonsuperior.com/docs/default-source/handbooks/rebarsplicinghandbook.pdf>.

3.3.1 Bar-Lock: All bolts shall be tightened until the lock-shear bolt heads are sheared off, regardless of the torque



applied. The approximate torque values described in [Table 1](#) of this report are for reference only. Installation shall be in accordance with the manufacturer's installation instructions.

3.3.2 Taper-Lock: Installation shall be in accordance with the manufacturer's installation instructions. The connection between the threaded reinforcing bar and coupler shall be secured to a minimum torque of 5 lb-ft (6.78 N-m) and not more than the maximum torque value shown in [Table 2](#) of this report.

3.3.2.1 Standard Coupler: The Taper-Lock Standard Coupler is used to join straight bars of the same size.

3.3.2.2 Flange Coupler: The Taper-Lock Flange Coupler is similar to the Taper-Lock Standard Coupler, except that the Taper-Lock Flange Coupler has a non-structural form mounting plate attached to one end of the coupler. The mounting plate provides a method of securing the coupler and attaching reinforcing bars to the formwork. Installation procedures are the same as those for the Taper-Lock Standard couplers described in Sections 3.3.2 and 3.3.2.1 of this report. The connection shall be secured to a minimum torque of 5 lb-ft (6.78 N-m) and not more than the maximum torque value shown in [Table 2](#) of this report.

3.3.2.3 Transitional Coupler: The Taper-Lock Transitional Coupler is similar to the Taper-Lock Standard Coupler, except the coupler is designed to connect reinforcing bars of different sizes. The connection shall be secured to a minimum torque of 5 lb-ft (6.78 N-m) and not more than the maximum torque value shown in [Table 2](#) of this report.

3.3.2.4 Positional Coupler: The Taper-Lock Positional Coupler is used to join curved or bent bars that shall be kept in a predetermined position during the joining process. The Positional Coupler allows only the coupler to rotate. Installation shall be in accordance with the manufacturer's installation instructions. The connection shall be secured to a minimum torque of 5 lb-ft (6.78 N-m) and not more than the maximum torque value shown in [Table 2](#) of this report. The final end-to-end distance of the bars shall comply with [Figure 2](#) and [Table 2](#) of this report. Finally, the lock nut shall be tightened to a minimum torque of 5 lb-ft (6.78 N-m) and not more than the maximum torque value shown in [Table 2](#) of this report.

3.3.2.5 Weldable Half Coupler: The Taper-Lock D360 Weldable Half Coupler provides a mechanical means of connecting reinforcing bars to structural steel plates or sections. The connection shall be secured to a minimum torque of 5 lb-ft (6.78 N-m), and not more than the maximum torque value shown in [Table 2](#) of this report.

3.3.3 DB/DI

3.3.3.1 DB Coupler: The DB coupler is secured to concrete formwork with screws, nails, or bolts to the flange plate at the coupler's barrel end as shown in [Figure 3](#) of this report. The

opposite end of the DB coupler shall be secured against displacement and supported before concrete placement.

3.3.3.2 DI Bar: The DI Bar shall be of sufficient length to provide development length as required by ACI 318-19 and -14 Sections 25.4.2, 25.4.9, and 25.4.10 (ACI 318-11 and -08 Sections 12.2 and 12.3). The DI Bar shall be lap-spliced with reinforcing steel that conforms to Chapter 25 of ACI 318-19 and -14 (Chapter 12 of ACI 318-11). After the forms are removed, the threaded end of the DI bar shall be threaded into the exposed barrel end of the DB coupler to the full thread engagement of the DI.

3.3.3.3 DB/DI Hooked Bar: The DB and DI Hooked Bars shall be bent cold, unless otherwise permitted by a registered designed professional conforming to Section 26.6.3.2(a) of ACI 318-19 for the 2021 IBC, Section 26.6.3.1(a) of ACI 318-14 for the 2018 and 2015 IBC, or Section 7.3.1 of ACI 318-11 for the 2012 IBC and 2009 IBC Section 1907.3, as applicable. The 90 and 180-degree hook bends shall be installed as conforming to Section 25.3.1 of ACI 318-14 (Sections 7.1.2 and 7.1.1 of ACI 318-11). The hooked bars' properties and illustrations are shown in [Table 3](#) and [Figure 3](#) of this report.

3.3.3.4 DB/DI Double-Ended Bar: The double-ended bars are integrally forged from deformed bar material and are configured with either a DB coupler or a DI bar on both ends, or a DB coupler on one end and a DI bar on the other end. Double-ended bars are used to establish a direct load path through a concrete section, thus avoiding multiple hooked bars and reducing rebar congestion. The double-ended bars' properties and illustrations are shown in [Table 3](#) and [Figure 3](#) of this report.

3.3.3.5 End Anchorage: The headed DI bar and headed DB coupler each include the opposite end forged into a bolt head configuration. Only the DI bar and DB coupler portions of this product are evaluated by this report. Treatments and connections to the opposite end of the DB or DI bar shall comply with Section 3.3.3.6 of this report. The headed bar properties and illustrations are shown in [Table 3](#) and [Figure 3](#) of this report.

3.3.3.6 Other Variations: Treatments and connections to the opposite end of the DB or DI bar are outside the scope of this report. The treatments and connections shall be in accordance with the applicable code requirements, referenced in an evaluation report issued by an approved and accredited evaluation agency or as other use specified by the registered design professional and approved by the building official.

3.4 Special Inspection: Special inspection of the mechanical couplers shall be provided at the job site as required by Section 1705 of the 2021, 2018, 2015, and 2012 IBC (Section 1704 of the 2009 IBC), as applicable. In addition to verifying the installation of steel reinforcing bar splices in accordance with this report, the special inspector shall verify the grade and size of reinforcing bars, coupler identification,



reinforcing bar embedment length to couplers, position of couplers, placement of reinforcing bar splices, as well as installation of the couplers to the reinforcing bars.

4.0 PRODUCT DESCRIPTION

4.1 Bar-Lock Product Information: XL-, L- and S/CA-series couplers consist of lock-shear bolts threaded into the side of seamless, hot-rolled steel tubing. The couplers have two serrated steel strips, the same length as the coupler, inside the tubing. The lock-shear bolts have conical ends that are driven into the reinforcing bars when the bolts are tightened. The heads of the lock-shear bolts are designed to shear off when installed to the approximate installation torque specified in [Table 1](#) of this report. The Bar-Lock XL-, L- and S/CA-Series Couplers are designed to mechanically join No. 4 through No. 12, No. 14, and No. 18 reinforcing bars in the Grades described in [Figure 1](#) and [Table 1](#) of this report.

4.1.1 Couplers: The Bar-Lock couplers are manufactured from a proprietary grade steel having a minimum tensile strength of 100,000 psi (689 MPa) and conforming to the requirement between those values specified for ASTM A519 Grades 1030 and 1035. The bolts are manufactured from steel complying with ASTM A331 Grade 41L40. The Bar-Lock XL-, L- and S/CA-Series couplers have similar properties, except for lengths and the number of lock-shear bolts used.

4.1.2 Steel Reinforcing Bars: Steel reinforcing bars shall be uncoated, deformed reinforcing bars complying with ASTM A615 Grades 60, 75, or 80; or ASTM A706 Grade 60 or 80 specifications. The scope of applicability for steel reinforcing bars conforming with Grade 75 only applies when used with ASTM A615-18 or older editions.

4.2 Taper-Lock Product Information: The Taper-Lock Reinforcing Bar Couplers consist of a tapered threaded system in five different configurations known as Standard, Flange, Transitional, Positional, and Weldable. The Standard, Flange, Transitional, and Positional couplers are designed to mechanically join No. 4 through No. 12, No. 14, and No. 18, and the Weldable Half Couplers are designed to mechanically join No. 4 through No. 11, No. 14, and No. 18 sizes for the grades of steel reinforcing bars described in [Table 2](#) of this report. All coupler styles have interior tapered threads for joining the reinforcing bars with matching threaded ends. [Figure 2](#) of this report illustrates the couplers.

4.2.1 Couplers: The Taper-Lock couplers are formed from steel described in the approved quality manual. The couplers may be provided with an epoxy coating conforming to ASTM A934 with the threads uncoated. The Weldable Half Coupler is manufactured using ASTM A108 CD8620 weldable grade steel.

4.2.2 Steel Reinforcing Bars: Deformed steel reinforcing bars shall comply with ASTM A615 Grades 60, 75, or 80; or ASTM A706 Grades 60 or 80 specifications. The scope of applicability for steel reinforcing bars conforming with

Grade 75 only applies when used with ASTM A615-18 or older editions. The reinforcing bars may be epoxy-coated in accordance with ASTM A934, as defined by ACI 318. The epoxy coating shall be applied to the reinforcing bars prior to the threading of the ends. The threading procedure removes the epoxy coating. The reinforcing bars shall have threaded ends conforming to the manufacturer's specification for fitting into the couplers.

4.3 DB/DI Product Information: DB/DI Reinforcing Bar Mechanical Splice System consists of a dowel bar coupler (DB coupler) and dowel-in bar (DI bar), as shown in [Figure 3](#) of this report. The DI bars are joined to DB couplers of the same splice size in steel reinforcing bar sizes No. 4 through No. 11. The coupler end of the DB coupler has an interior threaded barrel with a flange plate. The externally threaded end of DI bars is manufactured in two configurations: Standard DI and Extended DI. The DI bars may be bent cold in accordance with ACI 318-19 Section 26.6.3.2(a) for the 2021 IBC, ACI 318-14 Section 26.6.3.1 (a) for the 2018 and 2015 IBC, or ACI 318-11 and -08 Section 7.3.1 for the 2012 IBC and 2009 IBC Section 1907.3, as shown in [Figure 3](#) of this report.

4.3.1 DB Coupler and DI Bar: The DB coupler and corresponding DI bar are formed from steel conforming to ASTM A706 or ASTM A615 Grade 60.

4.3.2 Steel Reinforcing Bars: Steel reinforcing bars shall be uncoated, Grade 60 deformed reinforcing bars complying with ASTM A615 or ASTM A706.

4.3.3 Coatings: Finished DB couplers and DI bar may be coated with epoxy or zinc (hot-dip galvanized), except for the threads. Such coatings shall comply with and be applied in accordance with ACI 318-19 Section 20.5.2.1, ACI 318-14 Section 20.6.2.1, or ACI 318-11 or -08 Section 3.5.3.8. The zinc hot-dip galvanized coating has a matte gray finish. Coatings such as zinc electroplating conforming to the requirements of ASTM B633 have a bright silver or silver-gold finish and may be applied to finished DB couplers and DI bars, including threads. Coatings not complying with ACI 318-19 Section 20.5.2.1, ACI 318-14 Section 20.6.2.1, or ACI 318-11 or -08 Section 3.5.3.8 are allowed, but not considered corrosion resistant.

5.0 IDENTIFICATION

The Bar-Lock, Taper-Lock, and DB/DI Splicing Systems are packaged with a label bearing the manufacturer's name (Dayton Superior Corporation), address, model, size, product name, and evaluation report number (ER-319).



Originally Issued: 04/18/2014

Revised: 04/09/2024

Valid Through: 04/30/2025

Either of the IAPMO Uniform Evaluation Service Marks of Conformity may also be used as shown below:

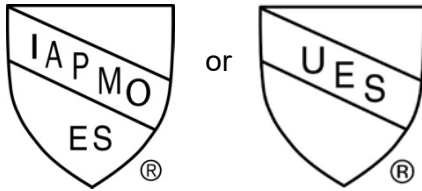

IAPMO UES ER-319

5.1 Bar-Lock: XL-, and L- series couplers are permanently stamped/labeled with the catalog number, size, heat number, Type 2 Splice designation. S/CA-series couplers are permanently stamped/labeled with “T1/T2” for Type 1 or Type 2 as their Splice designation and is dependent on the code edition specified.

5.2 Taper-Lock: Each Taper-Lock coupler is permanently stamped/labeled with the size, heat number, Type 1 or Type 2 Splice designation, and the mark "TLX" where "X" refers to either S, T, P, or W for the coupler type (Standard, Transitional, Positional, or Weldable, respectively). The high-strength couplers (D315, D325, D335, D345) will have a single band around the circumference of the coupler.

5.3 DB/DI: Each DB coupler and DI rebar is permanently stamped/labeled with the catalog number, size, heat number, Type 1 or Type 2 Splice designation, and the mark “T2” or “M2” where “T” refers to the city of the manufacturing facility (T for Tremont, Pennsylvania and M for Modesto, California) and “2” refers to the splice designation.

6.0 SUBSTANTIATING DATA

6.1 Data submitted in accordance with the ICC-ES Acceptance Criteria for Mechanical Splice Systems for Steel Reinforcing Bars (AC133).

6.2 Test reports are from laboratories in compliance with ISO/IEC 17025.

7.0 STATEMENT OF RECOGNITION

This evaluation report describes the results of research completed by IAPMO Uniform Evaluation Service on Dayton Superior Corporation Mechanical Splice Systems for Reinforcing Bars to assess conformance to the codes shown in Section 1.0 of this report and serves as documentation of the product certification. The systems are produced at locations noted in Section 2.17 of this report under a quality control program with periodic inspection under the supervision of IAPMO UES.

For additional information about this evaluation report please visit www.uniform-es.org or email us at info@uniform-es.org

TABLE 1- Bar Lock Coupler System

Bar Size	Coupler Size and Designation				Coupler Specifications							
	XL-	L-	S/CA-		OD (in)	Approximate Bolt Torque ² (ft-lbs)	Length			Number of Bolts		
	Type 1 or Type 2	Type 1 or Type 2	Type 1	Type 2 ³			XL-	L-	S/CA-	XL-	L-	S/CA-
	A615 Grade 75 ⁴ & 80 A706 Grade 80	A615 or A706 Grade 60	A615-18 or previous or A706 Grade 60	A615-20 or newer or A706 Grade 60								
No. 4	4XL-N ¹	4L-N ¹	4S-N ¹ -CA	4S-N ¹ -CA	1.3	40	10.2	5.5	3.9	12	6	4
No. 5	5XL-N ¹	5L-N ¹	5S-N ¹ -CA	5S-N ¹ -CA	1.7	80	11.5	6.3	4.5	12	6	4
No. 6	6XL-N ¹	6L-N ¹	6S-N ¹ -CA	6S-N ¹ -CA	1.9	80	13.2	8.0	6.3	14	8	6
No. 7	7XL-N ¹	7L-N ¹	7S-N ¹ -CA	7S-N ¹ -CA	1.9	80	14.9	9.8	8.0	16	10	8
No. 8	8XL-N ¹	8L-N ¹	8S-N ¹ -CA	8S-N ¹ -CA	2.2	180	18.6	12.3	10.2	16	10	8
No. 9	9XL-N ¹	9L-N ¹	9S-N ¹ -CA	9S-N ¹ -CA	2.9	350	19.1	11.5	9.0	14	8	6
No. 10	10XL-N ¹	10L-N ¹	10S-N ¹ -CA	10S-N ¹ -CA	2.9	415	21.5	14.0	11.5	16	10	8
No. 11	11XL-N ¹	11L-N ¹	11S-N ¹ -CA	11S-N ¹ -CA	3.1	415	24.1	16.5	14.0	18	12	10
No. 12	-	12L-N ¹	-	-	3.1	415	-	16.5	-	-	12	-
No. 14	14XL-N ¹	14L-N ¹	14S-N ¹ -CA	14S-N ¹ -CA	3.5	475	29.1	21.6	19.2	22	16	14
No. 18	18XL-N ¹	18L-N ¹	18S-N ¹ -CA	18S-N ¹ -CA	4.3	475	44.8	32.2	27.0	34	24	20

For SI: 1 inch=25.4 mm, 1 lbf-ft=1.356 Nm

¹ 'N' denotes the production lot number. Section 5.0 of this report provides additional information.

² Torque values are for reference only. All bolts shall be tightened until the heads are sheared off regardless of torque applied. See Section 3.3.1 of this report.

³ ASTM A615-20 reduced the required tensile strength for Grade 60 rebar from 90 ksi (620 MPa) to 80 ksi (551 MPa).

The S/CA coupler may be specified as Type 2 provided the engineering specifications were developed in accordance with ASTM A615-20 newer.

⁴ The scope of applicability for Grade 75 is described in Section 4.1.2 of this report, which varies with the edition of ASTM A615.

FIGURE 1 – Bar-Lock Coupler System

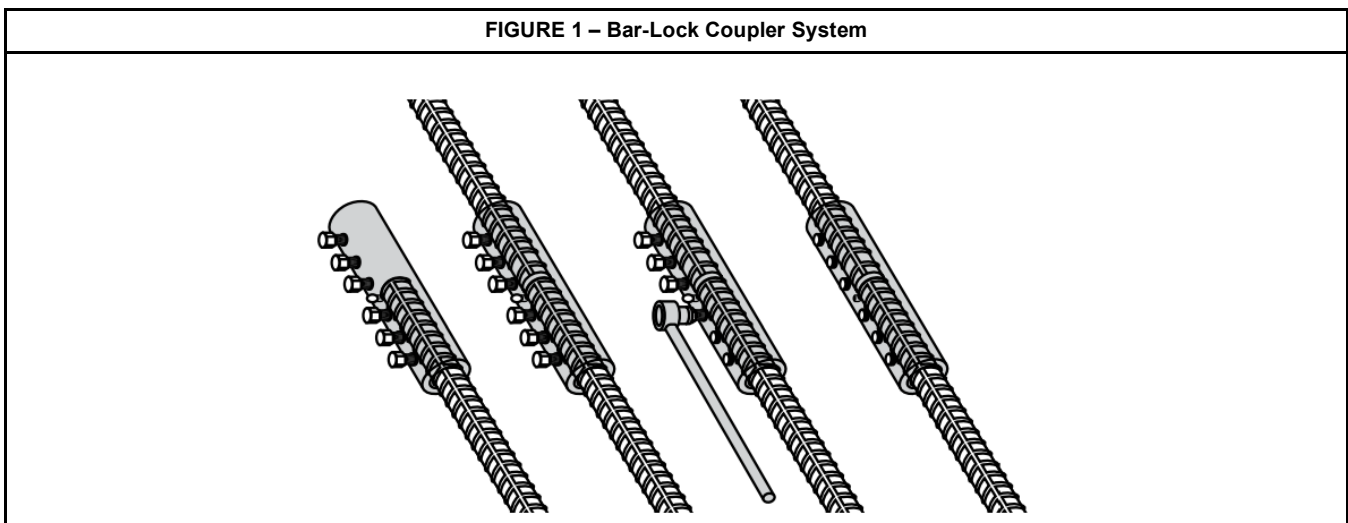



TABLE 2 - Taperlock Coupler Specifications

Style	Catalog Number	Product Marking	No. 4	No. 5	No. 6	No. 7	No. 8	No. 9	No. 10	No. 11	No. 12	No. 14b	No. 18b	No. 14	No. 18
Standard	D310	TLS	A615 Grade 60,75 ¹ , or 80 A706 Grade 60, or 80 Type 1 or Type 2											A615-20 or newer Grade 60 or 80 Type 1 or Type 2 ² ; A615-18 or earlier Grade 60 or 75 ¹ Type 2; A615- 18 Grade 80 Type 1 ; A706 Grade 60 or 80 Type 1 or Type 2	
Transitional	D320	TLT													
Positional	D330	TLP													
Flange	D340	TLF													
Weldable	D360	TLW	A615 Grade 60, 75 ¹ , or 80 A706 Grade 60 or 80 Type 1 or Type 2								N/A		A615 Grade 60, 75 ¹ , or 80 A706 Grade 60 or 80 Type 1 or Type 2		
Standard	D315	TLS	A615 Grade 60, 75 ¹ , or 80 A706 Grade 60 or 80 Type 1 or Type 2											N/A	
Transitional	D325	TLT													
Positional	D335	TLP													
Flange	D345	TLF													
Reinforcing Bar Connection Minimum Torque (ft-lbs)			5												
Reinforcing Bar Connection Maximum Torque (ft-lbs)			55	81	111	151	199	207	210	225	225	247	247	247	247
Positional	Lock Nut Max Torque (ft-lbs)		17	24	33	45	60	62	69	69	69	91	99	91	99
	Bar to Bar Distance, Min (in)		3.3	3.6	3.6	4.3	4.8	4.9	5.4	5.9	6.2	6.8	8.6	6.8	8.6
	Bar to Bar Distance, Max (in)		4.3	4.8	4.7	5.8	6.7	6.8	7.2	8.0	8.5	9.4	12.0	9.4	12.0
Thread Pitch (mm)			2.0	2.0	2.0	2.5	2.5	2.5	2.5	2.5	2.5	3.0	3.0	2.5	2.5
For I: 1"-25.4 mm, 1 ft-lb - 1.356 mm															

For SI: 1 inch=25.4 mm, 1 lbf-ft=1.356 Nm

¹ The scope of applicability for Grade 75 is described in Section 4.2.2 of this report, which varies with the edition of ASTM A615.

² ASTM A615-20 reduced the required tensile strength for Grade 80 rebar from 105 ksi (724 MPa) to 100 ksi (690 MPa). The D310, D320, D330, and D340 No.14 and No.18 bars may be specified as a Type 2 for Grade 80 reinforcement provided the engineering specifications were developed in accordance with ASTM A615-20 or newer.

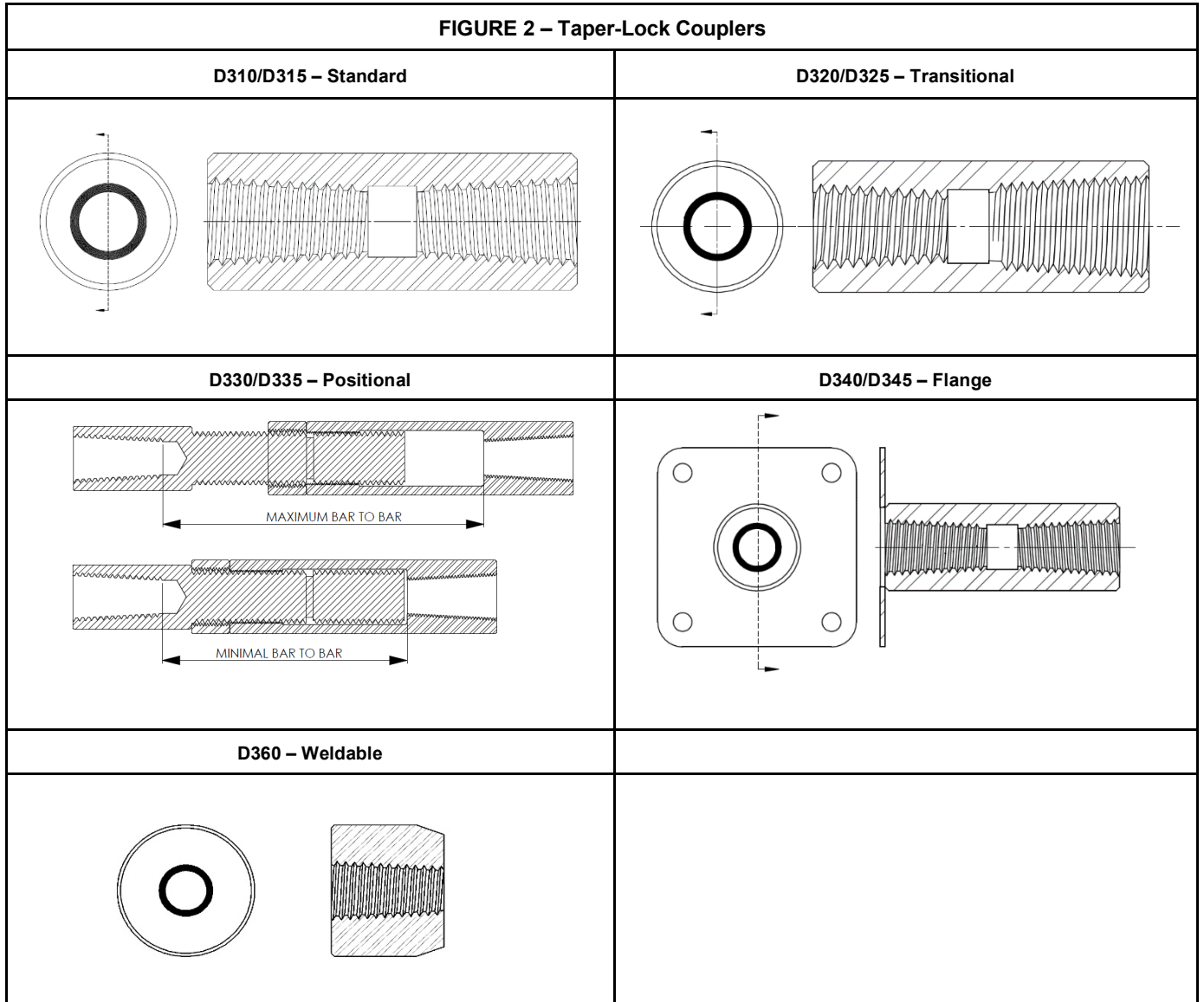

For SI: 1 Inch = 25.4 mm

TABLE 3 – DB/DI Coupler System

Rebar Size	Thread Size (in)	Flange Dia. (in)	A (in)	B (in)	C (in)	D (in)	E (in)	F (in)	G (in)	Min L _{DI} (in)	Min L _{DB} (in)	Min R (in)
No. 4	5/8-11 UNC	1.875	1.25	0.125	0.688	0.855	1.00	8.0	4.50	8.0	12.0	1.50
No. 5	3/4-10 UNC	2.063	1.563	0.125	0.813	1.042	1.13	10.0	5.00	8.0	12.0	1.88
No. 6	7/8-9 UNC	2.25	1.625	0.125	0.938	1.23	1.25	12.0	6.00	8.0	14.0	2.25
No. 7	1-8 UNC	2.438	1.813	0.125	1.063	1.417	1.375	14.0	7.00	8.0	16.0	2.63
No. 8	1 1/8-8 UN	2.625	2.063	0.125	1.188	1.603	1.50	16.0	8.00	14.0	16.0	3.00
No. 9	1 1/4-8 UN	2.813	2.188	0.125	1.313	1.786	1.625	19.38	10.38	14.0	16.0	4.75
No. 10	1 7/16-8 UN	3.00	2.438	0.125	1.50	1.982	1.813	21.56	11.73	14.0	16.0	5.38
No. 11	1 9/16-8 UN	3.25	2.563	0.125	1.625	2.219	1.938	23.88	13.05	14.0	16.0	6.00

FIGURE 3 – DB/DI Coupler System

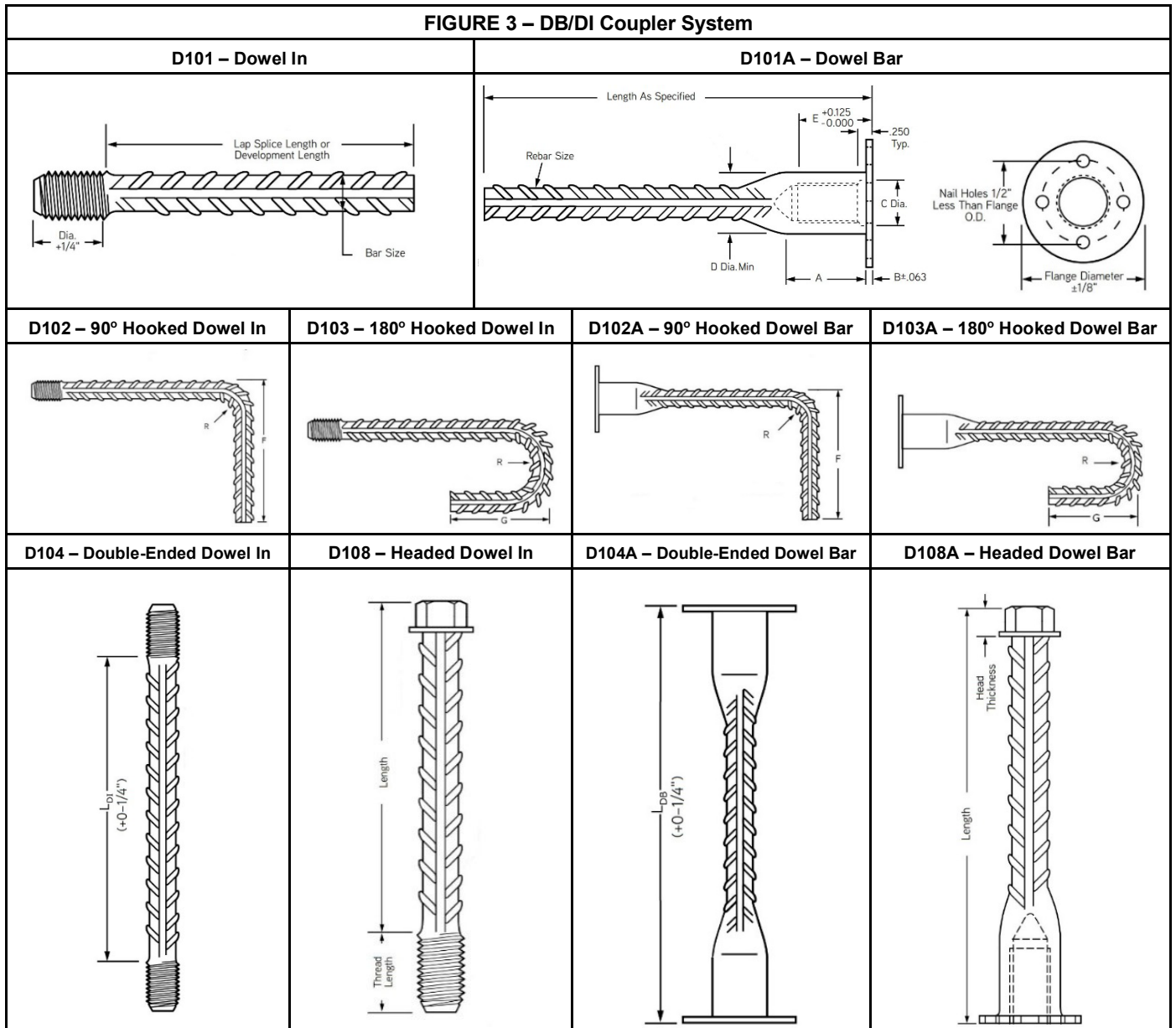



CITY OF LOS ANGELES SUPPLEMENT

DAYTON SUPERIOR CORPORATION

1125 Byers Road
Miamisburg, OH 45342
800-745-3700
www.daytonsuperior.com

MECHANICAL SPLICE SYSTEMS FOR STEEL REINFORCING BARS:

- BAR-LOCK
- TAPER-LOCK
- DB/DI

CSI Section:

03 21 00 Reinforcing Steel

1.0 RECOGNITION

The Dayton Superior Mechanical Splice Systems for Steel Reinforcing Bars described in ER-319 and this supplemental report have been evaluated for use as mechanical splices for deformed steel reinforcing bars in concrete structural members. The Dayton Superior Mechanical Splice Systems for Steel Reinforcing Bars have been evaluated for structural performance properties, subject to the requirements in ER-319 and this supplemental report. The Dayton Superior Mechanical Splice Systems for Steel Reinforcing Bars were evaluated for compliance with the following codes and regulations:

- 2023 City of Los Angeles Building Code (LABC)
- 2023 City of Los Angeles Residential Code (LARC)

2.0 LIMITATIONS

Use of the Dayton Superior Mechanical Splice Systems for Steel Reinforcing Bars recognized in this supplement is subject to the following limitations:

2.1 The design, installation, and inspection of the Dayton Superior Mechanical Splice Systems for Steel Reinforcing Bars shall be in accordance with the 2021 International Building Code and the 2021 International Residential Code as noted in ER-319.

2.2 Continuous special inspections of the mechanical splicing systems during installation shall be provided by Registered Deputy Inspectors as required by Section 1705 of the 2023 LABC, as applicable. The Registered Deputy Inspector shall verify the following: hardware and equipment; cleaning and condition of the bars in accordance with the specifications and the applicable code; and the installation procedures comply with the specifications and the manufacturer's published installation instructions.

2.3 The fabricator of the steel couplers shall be required to maintain a detailed procedure for material control and

suitable procedures and records attesting that the specified coupler has been furnished. The applicable splice designation (Type 1 or Type 2) or coating, as applicable, shall be included in each packaging assembly prior to shipment from the fabricator's plant. The fabricator's identification mark designation shall be established and on record prior to fabrication. Couplers that are not identifiable from marking and test records shall be tested to determine conformity to this report. The fabricator shall furnish an affidavit of compliance and test data shall be provided upon request.

2.4 The Dayton Mechanical Splice Systems shall be selected at the job site by the Registered Deputy Inspector or by the building inspector and shall be tested by an approved testing agency in accordance with Section 1703 of the LABC. The test shall be conducted on each different rebar size and the frequency of tests shall be as follows: one out of the first ten splices; one out of the next ninety splices; one out of the next one hundred splices. The splice shall develop in tension or compression, as required, at least 125 percent of the specified yield strength of the bar as per Section 25.5.7.1 of ACI 318-19 and -14. For Type 2 splices, the splice shall develop at least 100 percent of the specified tensile strength of the steel reinforcing bar.

For Type 2 splices only, if failure of the tested splice should occur prior to obtaining the 125-percent of the specified yield strength and the 100-percent of the specified tensile strength, then 25 percent of all couplers shall be tested for both specified yield strength and specified tensile strength. If failure of the tested Type 2 splice occurs with testing of the 25 percent requirement, as stated above, then all couplers shall be rejected.

2.5 Minimum concrete cover and spacing between bars or sleeves shall be provided in accordance with Section 1808.8.2 of the 2023 LABC.

2.6 The Dayton Superior Mechanical Splice Systems for Steel Reinforcing Bars shall be installed in accordance with the applicable code, manufacturer's installation instructions, and this supplement. A copy of the manufacturer's installation instructions or specifications shall be available on-site for all Registered Deputy Inspectors.

2.7 Splice locations shall be noted on the plans approved by the building official. The plans and details shall be prepared, stamped, and signed by a California registered design professional, when required by the LABC or LARC.

2.8 Only qualified operators, specified by the manufacturer, completely familiar with the installation procedures and specifications shall perform the splicing.

2.9 This supplement expires concurrently with ER-319.

For additional information about this evaluation report please visit www.uniform-es.org or email us at info@uniform-es.org