

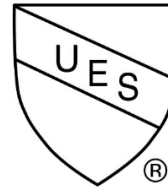

DAYTON SUPERIOR CORPORATION
 1125 Byers Road
 Miamisburg, OH 45342
 800-745-3700
www.daytonsuperior.com



IAPMO UES ER-319

Scope of Evaluation Report – ER 319

Mechanical Splice Systems for Steel Reinforcing Bars: 1) Bar-Lock; 2) Taper-Lock; 3) DB/DI			
CSI Category: 03 21 00 Reinforcing Steel			
Codes or Standards	Version	Evaluated Characteristics	Evaluated Uses
International Building Code® (IBC)	2021, 2018, 2015, 2012, and 2009	Quality Strength Effectiveness Fire Resistance Durability Safety	Mechanically splice reinforcing bars installed in concrete structural members.
International Residential Code® (IRC)	2021, 2018, 2015, 2012, and 2009		
City of Los Angeles Building Code (LABC) – Supplement attached	2023		
City of Los Angeles Residential Code (LARC) – Supplement attached	2023		
Code Referenced Sections	IBC: 104.11, 1704.2.5.1, 1705 IRC: R104.11 ACI 318-19 and -14: 18.2.7.1; 18.2.7.2; R18.2.7; R18.5; R18.9; 18.12.7.4; 20.2.2.4; Table 20.2.2.4(a); 20.2.2.5; 25.4.2; 25.4.9; 25.4.10; 20.5.1; 25.5.7.1; 26.6.3.1(a)		

1.0 RECOGNITION

This report describes the results of research completed by IAPMO Uniform Evaluation Service on Dayton Superior Corporation’s Mechanical Splice Systems for Reinforcing Bars to assess conformance to the codes shown at the beginning of this report and serves as documentation of the product certification. Products are manufactured under a quality control program with periodic inspections under the supervision of IAPMO UES. The Dayton Superior Corporation’s Mechanical Splice Systems recognized in this report are manufactured in Tremont, PA; Rushsylvania, OH; Modesto, CA; Detroit, MI; Hastings, PA; Jiangsu, China; Baoding, China; and Rosemount, MN.

2.0 PRODUCT DESCRIPTION AND FIELD IDENTIFICATION OF DAYTON SUPERIOR MECHANICAL SPLICE SYSTEMS

2.1 Bar-Lock: The Bar-Lock XL-, L-, and S/CA-series couplers utilize lock-shear bolts and serrated grip rails to mechanically splice the reinforcing bars (rebar). The serrated grip rails embed into the rebar as the lock-shear bolts are torqued. The heads of the lock-shear bolts are designed to shear off at a prescribed torque as shown in Table 1 of this report. The Bar-Lock XL-, L-, and S/CA-series couplers are produced with steel that shall meet the following minimum specifications: tensile strength of 100 ksi that

The product described in this Uniform Evaluation Service (UES) Report has been evaluated as an alternative material, design or method of construction in order to satisfy and comply with the intent of the provision of the code, as noted in this report, and for at least equivalence to that prescribed in the code in quality, strength, effectiveness, fire resistance, durability and safety, as applicable, in accordance with IBC Section 104.11. This document shall only be reproduced in its entirety.





conforms with ASTM A519 Grades 1030 and 1035. The XL-, L-, and S/CA series couplers are all identical in their material properties other than the length and bolts used as shown in Table 1 of this report. The bolts used with the couplers are produced from steel as shown in Table 1 of this report. The couplers are used with uncoated steel reinforcing bars sizes in conformance with ASTM A615 or ASTM A706 Grades 60 or 80; or ASTM A615 Grade 75 specifications shown in Figure 1 and Table 1 of this report. The scope of the Grade 75 steel reinforcing bars usage is only applicable when it conforms with ASTM A615-18 or previous editions.

2.2 Taper-Lock: The Taper-Lock System couplers have different taper threaded coupler variations that are mechanically connected to the reinforcing bar sizes shown in Table 2a of this report. The Taper-Lock System couplers are produced from steel that has been evaluated in the Dayton Superior Corp. Quality Control Manual. The couplers may be used with compliant epoxy-coated bars (ASTM A934) in accordance with ACI 318-19 Table 20.5.2.1. The steel reinforcing bars sizes conform with either ASTM A615 or ASTM A706 Grades 60 or 80; or ASTM A615 Grade 75 specifications shown in Figure 2 and Table 2a of this report. The scope of the Grade 75 steel reinforcing bars usage is only applicable when it conforms with ASTM A615-18 or previous editions.

2.2.1 The D390 Taper-Lock Grout Sleeve is a ductile iron coupler designed to mechanically splice two pieces of rebar to form a connection. One side of the sleeve uses one of the Taper-Lock System (Section 2.2 of this report) and the other side uses a pump tube that is filled with a cementitious grout. The D390 Taper-Lock Grout Sleeve is used with the steel reinforcing bars sizes, dimensions, and illustrations are shown in Table 2b and Figure 2 of this report. Additional installation, testing, and inspection requirements are specified in Section 3.2.8 of this report.

2.2.2 D490 High Strength Splicing Grout shall be used with the D390 Taper-Lock Grout Sleeve described in Section 2.2.1 of this report. The grout shall comply with ASTM C1107 specifications and shall achieve a minimum compressive strength of 10,800 psi at full cure requirements when tested as set forth in ASTM C109. Each 50 lb grout unopened bag, when stored in a dry facility, has a shelf life of 12 months. The D390 Grout Sleeve Application Guide dated 9/12/2024 provides additional information on the storage, preparation, and placement of the product.

2.3 DBDI Splice System: The components of the DBDI Splice System are the male Dowel-In (DI) which is used with a female Dowel-Bar (DB) coupler bar to splice the reinforcing bars for the sizes shown in Table 3 of this report. The DB coupler consists of an integral, nailing flange, or a coupler forged from the end of the reinforcing with female threads as shown in Figure 3 of this report. The threaded end of the Dowel-In is produced in various configurations shown in Figure 3 of this report. The Dowel-In reinforcement may be bent cold prior to placement as set forth in ACI 318-19 26.6.3.2(a), ACI 318-14 26.6.3.1(a), or ACI 318-11 and -08 7.3.1 as shown in Figure 3 of this report. The uncoated steel reinforcing bar sizes used for the Dowel-Bar coupler and Dowel-In bar comply with ASTM A615 or ASTM A706 Grade 60.

2.3.1 The Dowel-Bar coupler and Dowel-In bar may be with epoxy-coated or zinc-coated (hot-dip galvanized), excluding the threads, and be applied and conform with ACI 318-19 20.5.2.1, ACI 318-14 20.6.2.1, or ACI 318-11 or -08 3.5.3.8. Coatings within the scope of ACI 318-19 20.5.2.1, ACI 318-14 20.6.2.1, or ACI 318-11 or -08 3.5.3.8 may be used, but are not considered corrosion resistant. The hot dip galvanized coating shall have a dull gray finish. Coatings with zinc electroplating shall comply with ASTM B633 and may be applied to the finished Dowel-Bar couplers and Dowel-In bars, including the threads. The electroplating coatings have a silver or silver-gold finish.

2.4 Identification: The Bar-Lock, Taper-Lock, and DB/DI Splicing Systems are packaged with tags on boxes, cartons, or other containers shall bear the company name (Dayton Superior Corporation), address, model, size, product name, and evaluation report number (ER-319) shown on the tags.

2.4.1 Bar-Lock: XL-, and L- series couplers are identified with tags on boxes, cartons, and other containers shall bear the company name and address. The tags shall also show the heat number, Type 2 splice designation, model, and size. S/CA-series couplers are identified with "T1/T2" for Type 1 or Type 2 as their splice designation and is dependent on the referenced code edition.

2.4.2 Taper-Lock: Each Taper-Lock coupler shall be indicated by the manufacturer's mark, "DSC", the connection Type 1 or Type 2 Splice designation. All couplers (except the D390) also have the model type "TLX" where X indicates "S" for Standard, "T" for Transitional, "P" for Positional, or "W" for Weldable for the coupler type. The high-strength couplers (D315, D325, D335, D345) will have a single band around the circumference of the coupler.

2.4.3 DB/DI: Each DB coupler and DI rebar tags/labels on bundles and containers shall bear the company name and address. The label will include a part number, work order number, lot number, raw material number, heat number, and date.



3.0 EVALUATION OF MECHANICAL SPLICE SYSTEMS TO REFERENCED CODES AND STANDARDS

The structural properties of the Mechanical Splice Systems comply with the intent of the provisions of the codes and regulations defined in this report. The Dayton Superior Mechanical Splice System, when used as to mechanically splice rebar system, meets the performance requirements as a Type I or Type 2 designation as defined by Sections 18.2.7.1 and 25.5.7.1 of ACI 318-19 and -14.

3.1 The mechanical splice systems mentioned in Sections 3.1.1 through 3.1.5 of this report for buildings that use special moment frames, special structural walls, and intermediate precast walls constructed of precast concrete and other structures, as applicable, are allowed to be used only in ACI 318-19 Chapter 18 (for use in the 2021 IBC or IRC).

3.1.1 Type 2 mechanical splices of either ASTM A706 or ASTM A615 Grade 60 reinforcement shall not be located within a distance equal to twice the member depth from the column or beam face for special moment frames or from critical sections where yielding of the reinforcement is likely to occur as a result of lateral displacements beyond the linear range of behavior as defined by ACI 318-19 18.2.7.2. Mechanical splices in special moment frames and special structural walls for Type 2 mechanical splices on Grade 80 and Grade 100 reinforcement may not be capable of resisting the stress levels expected in yielding regions as defined by ACI 318-19 R18.2.7, and this use is beyond the purview of this report.

3.1.2 Connections between precast wall panels or between wall panels and the foundation, in the plastic region, are required to resist forces and to provide yielding in the vicinity of connections as defined in ACI 318-19 R18.5. For the 2021 IBC or IRC, the combination of these mechanical splice systems and Grade 80 reinforcement has not been determined and is beyond the purview of this report.

3.1.3 Special moment frames constructed using precast concrete are expected to experience flexural yielding in connection regions as defined by ACI 318-19 and -14 R18.9 (ACI 318-11 and -08 R21.8). For the IBC or IRC, such uses of these mechanical splice systems are beyond the purview of this report.

3.1.4 Grade 80 reinforcement with mechanical splices is prohibited to transfer forces between the diaphragm and the vertical elements of the seismic-force-resisting system as defined by ACI 318-19 18.12.7.4 (for the 2021 IBC or IRC).

3.1.5 The Dayton Superior Mechanical Splice Systems specified for particular structural applications shall be used in accordance with Table 20.2.2.4(a) for deformed reinforcement as set forth in Section 20.2.2.4 of ACI 318-19 and -14, as applicable, for the 2021, 2018, and 2015 IBC or IRC.

3.1.6 Deformed reinforcement resisting earthquake-induced moment, axial force, or both, in special seismic systems and anchor reinforcement in Seismic Design Categories (SDC) C, D, E, and F as defined in ACI 318-19 20.2.2.5, shall comply with either ACI 318-19 Section 20.2.2.5 (a) or 20.2.2.5 (b) when used with the Dayton Superior Mechanical Splice Systems in the 2021 IBC or IRC.

3.1.7 Deformed reinforcement resisting earthquake-induced moment, axial force, or both, in special moment frames, special structural walls, and all components of special structural walls including coupling beams and wall piers as defined in ACI 318-14 20.2.2.5 or ACI 318-11 and -08 21.1.5.2, shall comply with either ACI 318-14 Section 20.2.2.5 (a) or 20.2.2.5 (b) when used with the Dayton Superior Mechanical Splice Systems in the 2018, 2015, and 2012 IBC Section 1905 or 2009 IBC Section 1908.

3.1.8 Special inspections shall be conducted following Section 3.2.10 of this report.

3.1.9 The minimum specified concrete cover shall comply with ACI 318-19 20.5.1, ACI 318-14 20.6.1, or ACI 318-11 and -08 7.7 when used with the 2021, 2018, 2015, 2012 and 2009 IBC, as applicable. The concrete cover shall be measured from the concrete surface to the outermost surface of the steel to which the cover requirement applies in accordance with IBC Section 1808.8.2.

3.1.10 The Taper-Lock couplers used with the threaded end of the rebar shall be fabricated according to the manufacturer's specifications. The fabricator approval will be based on the following provisions:

1. Approval shall be based on the review of the fabricator's written fabrication procedures and quality control manuals that provide a basis for control of materials and workmanship, with periodic auditing of fabrication and quality control practices by an approved agency or the building official. At the completion of fabrication, the approved fabricator shall submit a certificate of compliance to the owner or the owner's authorized agent for submittal to the building official as set forth in Section 1704.2.5.1 of 2021, 2018, and 2015 IBC, Section 1704.2.5.2 of the 2012 IBC, or Section 1704.2.2 of the 2009 IBC, as applicable.

2. The fabricator shall be qualified and audited by authorized personnel of Dayton Superior Corporation as per Quality Control Manual procedures.



3. The approved fabricator shall demonstrate the following items when approved by the building official for each coupler type and steel rebar size, which can be in the form of a certificate of compliance:

i. The approved fabricator prepares the rebar ends as required by the Dayton Superior Quality Manual under the QC Audit Checklist, Fabricator.

ii. Splices of each steel rebar approved by the fabricator and tested for a mechanical Type 2 splice shall develop in static tension at least 100 percent of the specified tensile strength of the bar and at least 125 percent of the specified yield strength of the bar in accordance with ACI 318-19 and -14 25.5.7.1 substantiated by reports of mill tests in accordance with Section 20.2.2.5 of ACI 318-19 for reinforcing bars complying with ASTM A615 submitted to the building official for approval in accordance with Section 1704.5 of the IBC.

iii. Splices for each steel rebar approved by the fabricator and tested for a mechanical Type 1 splice shall develop in static tension at least 125 percent of the specified yield strength bars in accordance with ACI 318-19 and -14 25.5.7.1 substantiated by reports of mill tests in accordance with Section 20.2.2.5 of ACI 318-19 for reinforcing bars complying with ASTM A615 submitted to the building official for approval in accordance with Section 1704.5 of the IBC.

3.1.11 Before rebar threading, the Taper-Lock couplers may be used in epoxy-coated reinforcement to be bonded shall be clean of ice, mud, oil, or other deleterious coatings that decrease bond while splicing occurs as set forth in ACI 318-19 and -14 26.6.1.2(d), or ACI 318-11 and -08 7.4.1.

3.1.12 The DB/DI minimum bar spacing and cover requirements shall comply with ACI 318-19 and -14 25.6.1.6 or ACI 318-11 Section 7.6 when used with the 2021, 2018, 2015, 2012, and 2009 IBC, as applicable.

3.1.13 Reinforcing bars shall be bent cold prior to placement in the applicable Dayton Superior Splice System in accordance with ACI 318-19 26.6.3.2, ACI 318-14 26.6.3.1, or ACI 318-11 and -08 7.3.1 when used with the 2021, 2018, 2015, 2012, and 2009 IBC, as applicable.

3.2 Installation Requirements and Limitations: Dayton Superior Corporation Mechanical Splice Systems for Reinforcing Bars shall be installed in accordance with the manufacturer's installation instructions, this evaluation report, and the IBC or IRC. Where conflicts occur between these provisions, the IBC or IRC shall apply in accordance with Section 102.4.1 of the IBC.

3.2.1 Installation of Bar-Lock: All bolts are turned until the heads shear off, in accordance with the manufacturer's published instructions. Table 1 of this report estimated torque values for the shearing.

3.2.2 Installation of Taper-Lock: The connection is created by assembling the Taper-Lock coupler into the rebar until hand-tight (5 ft-lbs) minimum torque and not exceeding the maximum torque as specified in Table 2a and Table 2b of this report.

3.2.3 Installation of D310 Standard Coupler: The D310 Standard Coupler is used to connect two pieces of rebar, where at least one of the bars is free to rotate.

3.2.4 Installation of D340 Flange Coupler: The connection is created by assembling the coupler into the rebar until hand-tight (5 ft-lbs) minimum torque and not exceeding the maximum torque as specified in Table 2a of this report. The Flange coupler is almost identical to the D310 Standard Coupler installation details, with the exception that it utilizes a mounting plate that is connected to one end of the coupler. This plate secures to the coupler, eliminating protruding rebar ends through formwork.

3.2.5 Installation of D320 Transitional Coupler: The connection is created by assembling the coupler into the rebar until hand-tight (5 ft-lbs) minimum torque and not exceeding the maximum torque as specified in Table 2a of this report. The D320 Taper-Lock is used to join two reinforcing bars of different sizes.

3.2.6 Installation of D330 Positional Coupler: The connection is created by assembling the coupler into the rebar until hand-tight (5 ft-lbs) minimum torque and not exceeding the maximum torque as specified in Table 2a of this report. The D330 Positional Coupler is used to join two bars of the same size where neither bar can be rotated.

3.2.7 Installation of D360 Weldable Half Coupler: The connection is created by assembling the coupler into the rebar until hand-tight (5 ft-lbs) minimum torque and not exceeding the maximum torque as specified in Table 2a of this report. The Taper-Lock D360 Weldable couplers provide a means of connecting reinforcing bars to structural steel plates or sections.

3.2.8 Installation of D390 Taper-Lock Grout Sleeve: The connection is created by assembling the grout sleeve into the rebar until hand-tight (5 ft-lbs) minimum torque and not exceeding the maximum torque as specified in Table 2b of this report. The D390 Taper-Lock Grout Sleeve manufacturer's installation instructions are included in the D390 Grout Sleeve Application Guide dated 9/12/2024, and available at this link: <https://www.daytonsuperior.com/home>. The steel reinforcing bars and grout sleeves shall be



solid, completely free of oil, wax, grease, sealers, paint, and other contaminants. The contaminants and all excess water shall be removed from the sleeve. For desired pumping consistency, 2.8 liters (5.9 pints) of clean potable water and a maximum of 3.1 liters (6.6 pints) per 50 lb (22.7 kg) grout bag are required. All materials shall be conditioned between 40°F and 80°F (4°C and 27°C) 24 hours before installation. Ambient and surface temperatures of between 40°F and 95°F shall be maintained. The D490 High Strength Grout at grout cure shall achieve a minimum compressive strength of 10,800 psi at full cure and compressive strength tests shall be completed to achieve the 10,800 psi (74.5 MPa) strength.

3.2.9 Installation of DBDI Splice System: The Dowel-Bar coupler may be attached to concrete formwork through the integral nailing flange plate shown in Figure 3 of this report. The DB coupler's other end shall be fastened for proper support during concrete placement. The Dowel-In bar length shall comply with the development length as set forth in ACI 318-19 and -14 25.4.2, 25.4.9, and 25.4.10 (ACI 318-11 and -08 12.2 and 12.3). Lap splices with reinforcing steel of the Dowel-In bars shall comply with ACI 318-19 and -14 Chapter 25 (ACI 318-11 Chapter 12). After the formwork is stripped, the second Dowel-In bar is threaded into the exposed end of the Dowel-Bar coupler to the full thread engagement of the Dowel-In bar. The DB and DI Hooked reinforcement bars shall be bent cold prior to placement, unless otherwise permitted by the registered design professional as set forth in ACI 318-19 26.6.3.2(a) of ACI 318-19 (IBC 2021), ACI 318-14 26.6.3.1(a) (IBC 2018 and 2015), or ACI 318-11 7.3.1 (IBC 2012 and 2009 Section 1907.3), as applicable. The Dowel Bar can be furnished straight, with a 90° or 180° hooked end, or double-ended as set forth in ACI 318-19 and -14 25.3.1 (ACI 318-11 7.1.1 and 7.1.2). The Dowel Bar 90° or 180° hooked bar specifications and details are shown in Table 3 and Figure 3 of this report, as applicable.

3.2.9.1 The DBDI Splice System Double-Ended dowel bars are integrally forged from deformed rebar material and may be used with the configurations for the Dowel-Bar coupler or Dowel-In bar either on both ends or one on each side as shown in Figure 3 of this report. The double-ended bars may be used to establish a direct load path through a concrete section, thus avoiding multiple hooked rebar and eliminating rebar congestion in accordance with the manufacturer's installation instructions. The double-ended bars' specifications and details are shown in Table 3 and Figure 3 of this report, as applicable.

3.2.9.2 The Headed Dowel-In bar and Dowel-Bar coupler both may be included with one end enlarged by forging and then threaded, and the other end forged into a bolt head configuration. The Dowel-In bar and Dowel-Bar coupler portion only are within the scope of evaluation of this report. Coatings and connections to the other end of the Dowel-In bars or Dowel-In couplers are beyond the purview of this report. The coatings and connections shall comply with the code requirements, referenced in a valid research report from approved sources or the design or method of construction shall be approved where the building official determines conformance with the codes. The headed Dowel-In bar and Dowel-Bar coupler specifications and details are shown in Table 3 and Figure 3 of this report.

3.2.10 Special Inspection: Where required, special inspection shall be provided in accordance with Chapter 17 of the IBC. The duties of the special inspector include verifying the installation of the Dayton Superior Mechanical Splice Systems to the rebar following the 2021, 2018, 2015, and 2012 IBC Section 1705.3 and Table 1705.3 and 2009 IBC Section 1704.4.

3.3 Design Requirements and Limitations: The Dayton Superior Mechanical Splice Systems have been evaluated to meet the design requirements of this section. The design shall consider concrete cover as specified in Section 3.1.9 of this report. The mechanical splices in special moment frames and special structural walls for the 2021 IBC and IRC are limited to the provision of Section 3.1.1 of this report.

4.0 REFERENCES

Data in accordance with ICC-ES AC133, manufacturer's descriptive literature, and installation instructions. Test reports are from laboratories in compliance with ISO/IEC 17025.

5.0 CONCLUSIONS

The result of the research conducted by IAPMO UES concludes that the Dayton Superior Corporation Mechanical Splice Systems for Reinforcing Bars, within the limitations defined in this report, meets the intent of the provisions of the IBC and IRC when approved by the building official.

For additional information about this evaluation report please visit www.uniform-es.org or email us at info@uniform-es.org

TABLE 1- Bar Lock Coupler System

Bar Size	Coupler Size and Designation				Coupler Specifications							
	XL-	L-	S/CA-		OD (in)	Approximate Bolt Torque ² (ft-lbs)	Length			Number of Bolts		
	Type 1 or Type 2	Type 1 or Type 2	Type 1	Type 2 ³						ASTM A331 Grade 41L40		
	A615 Grade 75 ⁴ & 80 A706 Grade 80	A615 or A706 Grade 60	A615-18 or previous or A706 Grade 60	A615-20 or newer or A706 Grade 60			XL-	L-	S/CA-	XL-	L-	S/CA-
No. 4	4XL-N ¹	4L-N ¹	4S-N ¹ -CA	4S-N ¹ -CA	1.3	40	10.2	5.5	3.9	12	6	4
No. 5	5XL-N ¹	5L-N ¹	5S-N ¹ -CA	5S-N ¹ -CA	1.7	80	11.5	6.3	4.5	12	6	4
No. 6	6XL-N ¹	6L-N ¹	6S-N ¹ -CA	6S-N ¹ -CA	1.9	80	13.2	8.0	6.3	14	8	6
No. 7	7XL-N ¹	7L-N ¹	7S-N ¹ -CA	7S-N ¹ -CA	1.9	80	14.9	9.8	8.0	16	10	8
No. 8	8XL-N ¹	8L-N ¹	8S-N ¹ -CA	8S-N ¹ -CA	2.2	180	18.6	12.3	10.2	16	10	8
No. 9	9XL-N ¹	9L-N ¹	9S-N ¹ -CA	9S-N ¹ -CA	2.9	350	19.1	11.5	9.0	14	8	6
No. 10	10XL-N ¹	10L-N ¹	10S-N ¹ -CA	10S-N ¹ -CA	2.9	415	21.5	14.0	11.5	16	10	8
No. 11	11XL-N ¹	11L-N ¹	11S-N ¹ -CA	11S-N ¹ -CA	3.1	415	24.1	16.5	14.0	18	12	10
No. 12	-	12L-N ¹	-	-	3.1	415	-	16.5	-	-	12	-
No. 14	14XL-N ¹	14L-N ¹	14S-N ¹ -CA	14S-N ¹ -CA	3.5	475	29.1	21.6	19.2	22	16	14
No. 18	18XL-N ¹	18L-N ¹	18S-N ¹ -CA	18S-N ¹ -CA	4.3	475	44.8	32.2	27.0	34	24	20

For SI: 1 inch=25.4 mm, 1 lbf-ft=1.356 Nm

¹ 'N' denotes the production lot number. Section 5.0 of this report provides additional information.

² Torque values are for reference only. All bolts shall be tightened until the heads are sheared off regardless of torque applied. See Section 3.3.1 of this report.

³ ASTM A615-20 reduced the required tensile strength for Grade 60 rebar from 90 ksi (620 MPa) to 80 ksi (551 MPa).

The S/CA coupler may be specified as Type 2 provided the engineering specifications were developed in accordance with ASTM A615-20 newer.

⁴ The scope of applicability for Grade 75 is described in Section 4.1.2 of this report, which varies with the edition of ASTM A615.

FIGURE 1 – Bar-Lock Coupler System

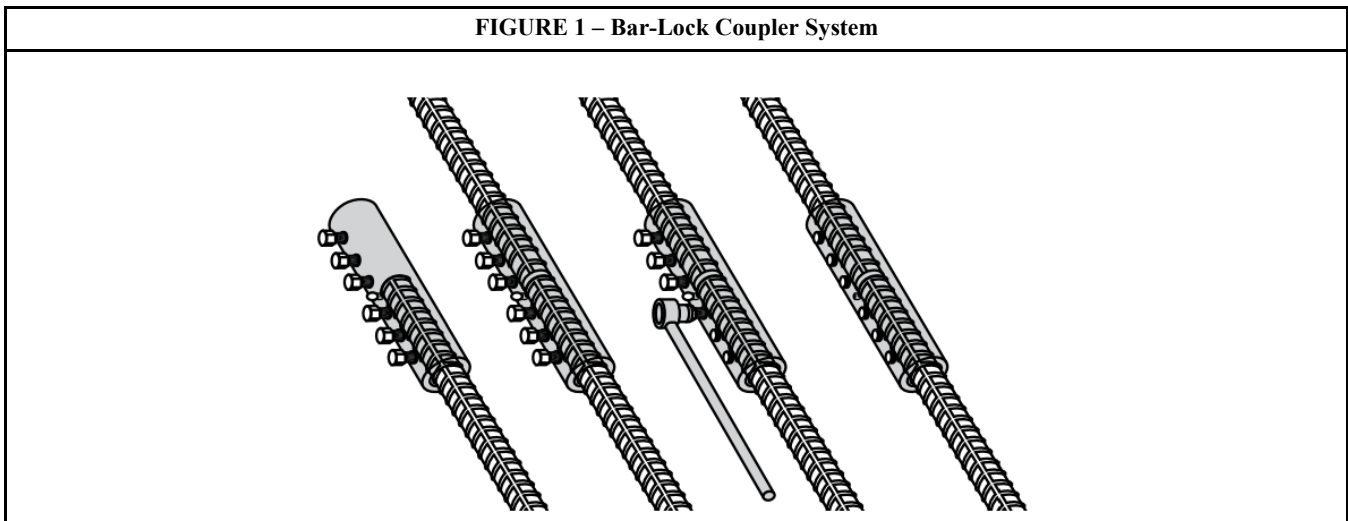



TABLE 2a – Taper-Lock Coupler Specifications

Style	Catalog Number	Product Marking	No. 4	No. 5	No. 6	No. 7	No. 8	No. 9	No. 10	No. 11	No. 12	No. 14b	No. 18b	No. 14	No. 18
Standard	D310	TLS	A615 Grade 60,75 ¹ , or 80 A706 Grade 60, or 80 Type 1 or Type 2											A615-20 or newer Grade 60 or 80 Type 1 or Type 2 ² ; A615-18 or earlier Grade 60 or 75 ¹ Type 2; A615-18 Grade 80 Type 1; A706 Grade 60 or 80 Type 1 or Type 2	
Transitional	D320	TLT													
Positional	D330	TLP													
Flange	D340	TLF													
Weldable	D360	TLW	A615 Grade 60, 75 ¹ , or 80 A706 Grade 60 or 80 Type 1 or Type 2									N/A		A615 Grade 60, 75 ¹ , or 80 A706 Grade 60 or 80 Type 1 or Type 2	
Standard	D315	TLS	A615 Grade 60, 75 ¹ , or 80 A706 Grade 60 or 80 Type 1 or Type 2											N/A	
Transitional	D325	TLT													
Positional	D335	TLP													
Flange	D345	TLF													
Reinforcing Bar Connection Minimum Torque (ft-lbs)			5												
Reinforcing Bar Connection Maximum Torque (ft-lbs)			55	81	111	151	199	207	210	225	225	247	247	247	247
Positional	Lock Nut Max Torque (ft-lbs)		17	24	33	45	60	62	69	69	69	91	99	91	99
	Bar to Bar Distance, Min (in)		3.3	3.6	3.6	4.3	4.8	4.9	5.4	5.9	6.2	6.8	8.6	6.8	8.6
	Bar to Bar Distance, Max (in)		4.3	4.8	4.7	5.8	6.7	6.8	7.2	8.0	8.5	9.4	12.0	9.4	12.0
Thread Pitch (mm)			2.0	2.0	2.0	2.5	2.5	2.5	2.5	2.5	2.5	3.0	3.0	2.5	2.5

For I: 1"-25.4 mm, 1 ft-lb - 1.356 Nm

(Footnotes for Table 2a and Table 2b are included on the next page)

TABLE 2b – Taper-Lock D390 Specifications^{1,4}

Bar Size	Sleeves per Bag of Grout ₃	Sleeve Dimensions (inches)				Taperlock Thread Specifications		
		A	B	C	D	Reinforcing Bar Connection Torque (ft-lbs)		Thread Pitch (mm)
						Min	Max	
No.4	122	5.97	4.75	2.14	1.26	5	55	2.0
No.5	79	7.03	5.75	2.30	1.42		81	2.0
No.6	47	7.90	6.50	2.61	1.73		111	2.0
No.7	35	8.87	7.25	2.77	1.89		151	2.5
No.8	27	10.07	8.26	2.89	2.01		199	2.5
No.9	21	11.05	9.00	3.04	2.16		207	2.5
No.10	17	12.02	9.77	3.32	2.32		210	2.5
No.11	12	12.98	10.26	3.67	2.67		225	2.5
No.14	7	15.99	13.27	4.12	2.99		247	2.5
No.18	3	21.63	18.00	5.26	3.76		247	2.5

For SI: 1 inch=25.4 mm, 1 lbf-ft=1.356 Nm, 1 liter = 0.26 gallons

¹ The scope of applicability for Grade 75 is described in Section 4.2.2 of this report, which varies with the edition of ASTM A615.

² ASTM A615-20 reduced the required tensile strength for Grade 80 rebar from 105 ksi (724 MPa) to 100 ksi (690 MPa). The D310, D320, D330, and D340 No. 14 and No. 18 bars may be specified as a Type 2 for Grade 80 reinforcement provided the engineering specifications were developed in accordance with ASTM A615-20 or newer.

³ The quantities are based on 3.1 liters of water per 50 lb bag of grout and only include the grout within the sleeves.

⁴ Compliant as a Type 1 or Type 2 mechanical splice when used with steel reinforcing bars in accordance with ASTM A615-20 or newer editions in Grades 60 and 80; ASTM A615-18 or older editions in Grades 60, 75, and 80; and ASTM A706 Grades 60 and 80.

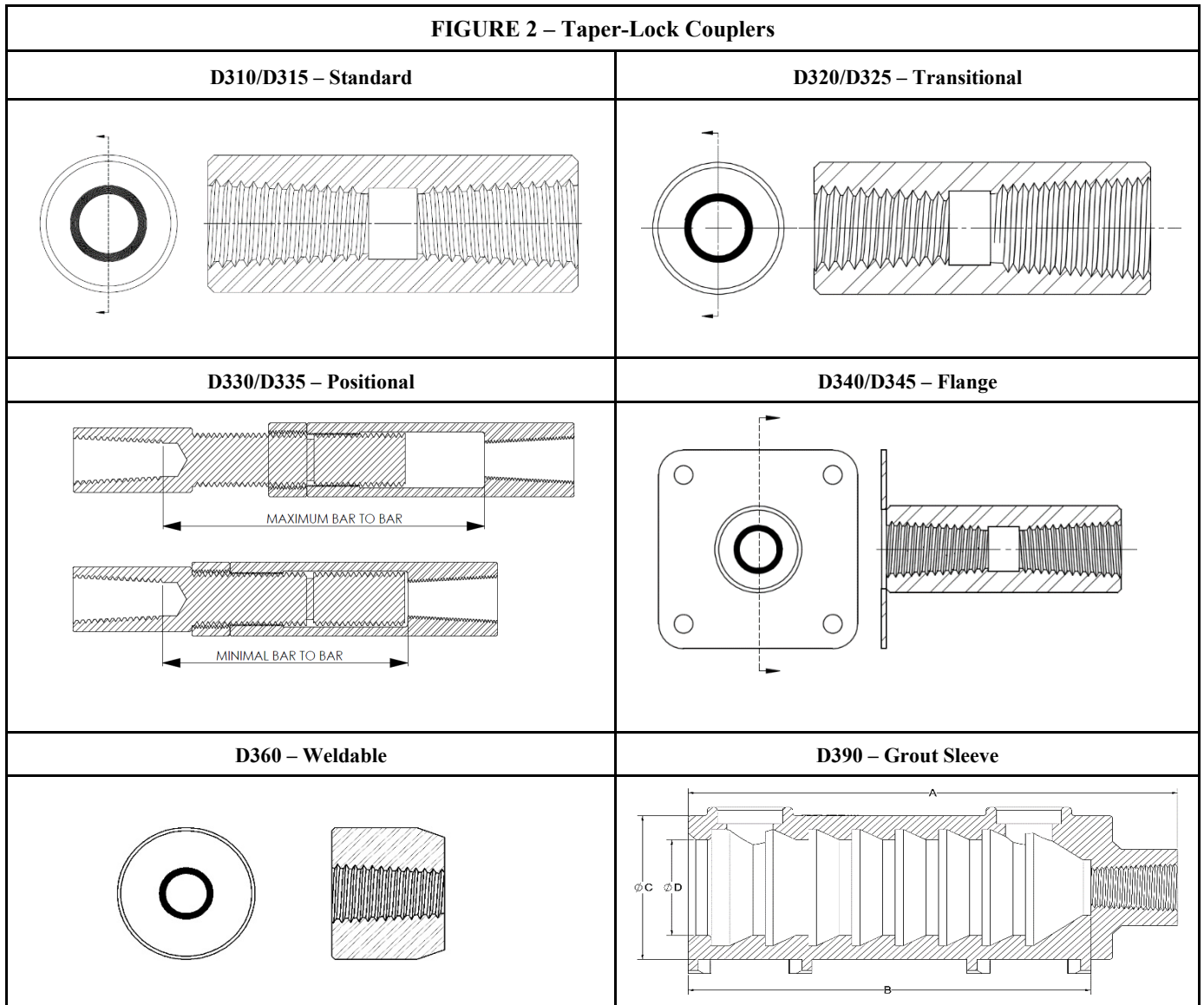

For SI: 1 Inch = 25.4 mm

TABLE 3 – DB/DI Coupler System

Rebar Size	Thread Size (in)	Flange Dia. (in)	A (in)	B (in)	C (in)	D (in)	E (in)	F (in)	G (in)	Min L _{DI} (in)	Min L _{DB} (in)	Min R (in)
No. 4	5/8-11 UNC	1.875	1.25	0.125	0.688	0.855	1.00	8.0	4.50	8.0	12.0	1.50
No. 5	3/4-10 UNC	2.063	1.563	0.125	0.813	1.042	1.13	10.0	5.00	8.0	12.0	1.88
No. 6	7/8-9 UNC	2.25	1.625	0.125	0.938	1.23	1.25	12.0	6.00	8.0	14.0	2.25
No. 7	1-8 UNC	2.438	1.813	0.125	1.063	1.417	1.375	14.0	7.00	8.0	16.0	2.63
No. 8	1 1/8-8 UN	2.625	2.063	0.125	1.188	1.603	1.50	16.0	8.00	14.0	16.0	3.00
No. 9	1 1/4-8 UN	2.813	2.188	0.125	1.313	1.786	1.625	19.38	10.38	14.0	16.0	4.75
No. 10	1 7/16-8 UN	3.00	2.438	0.125	1.50	1.982	1.813	21.56	11.73	14.0	16.0	5.38
No. 11	1 9/16-8 UN	3.25	2.563	0.125	1.625	2.219	1.938	23.88	13.05	14.0	16.0	6.00

FIGURE 3 – DB/DI Coupler System

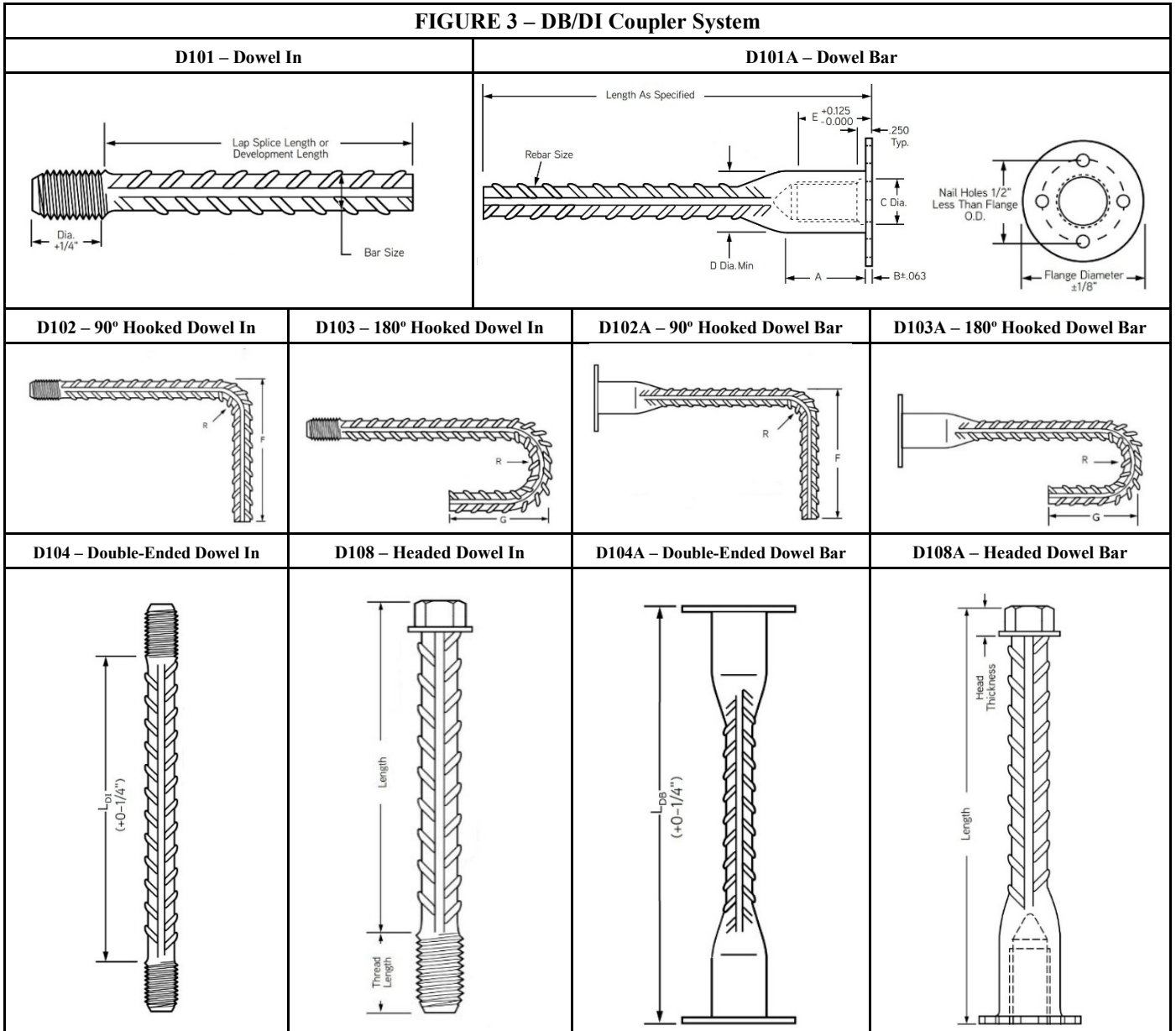



CITY OF LOS ANGELES SUPPLEMENT

DAYTON SUPERIOR CORPORATION

1125 Byers Road
Miamisburg, OH 45342
800-745-3700

www.daytonsuperior.com

MECHANICAL SPLICE SYSTEMS FOR STEEL REINFORCING BARS:

- BAR-LOCK
- TAPER-LOCK
- DB/DI

CSI Section:

03 21 00 Reinforcing Steel

1.0 RECOGNITION

The Dayton Superior Mechanical Splice Systems for Steel Reinforcing Bars described in ER-319 and this supplemental report have been evaluated for use as mechanical splices for deformed steel reinforcing bars in concrete structural members. The Dayton Superior Mechanical Splice Systems for Steel Reinforcing Bars have been evaluated for structural performance properties, subject to the requirements in ER-319 and this supplemental report. The Dayton Superior Mechanical Splice Systems for Steel Reinforcing Bars were evaluated for compliance with the following codes and regulations:

- 2023 City of Los Angeles Building Code (LABC)
- 2023 City of Los Angeles Residential Code (LARC)

2.0 LIMITATIONS

Use of the Dayton Superior Mechanical Splice Systems for Steel Reinforcing Bars recognized in this supplement is subject to the following limitations:

2.1 The design, installation, and inspection of the Dayton Superior Mechanical Splice Systems for Steel Reinforcing Bars shall be in accordance with the 2021 International Building Code and the 2021 International Residential Code as noted in ER-319.

2.2 Continuous special inspections of the mechanical splicing systems during installation shall be provided by Registered Deputy Inspectors as required by Section 1705 of the 2023 LABC, as applicable. The Registered Deputy Inspector shall verify the following: hardware and equipment; cleaning and condition of the bars in accordance with the specifications and the applicable code; and the installation procedures comply with the specifications and the manufacturer's published installation instructions.

2.3 The fabricator of the steel couplers shall be required to maintain a detailed procedure for material control and

suitable procedures and records attesting that the specified coupler has been furnished. The applicable splice designation (Type 1 or Type 2) or coating, as applicable, shall be included in each packaging assembly prior to shipment from the fabricator's plant. The fabricator's identification mark designation shall be established and on record prior to fabrication. Couplers that are not identifiable from marking and test records shall be tested to determine conformity to this report. The fabricator shall furnish an affidavit of compliance and test data shall be provided upon request.

2.4 The Dayton Mechanical Splice Systems shall be selected at the job site by the Registered Deputy Inspector or by the building inspector and shall be tested by an approved testing agency in accordance with Section 1703 of the LABC. The test shall be conducted on each different rebar size and the frequency of tests shall be as follows: one out of the first ten splices; one out of the next ninety splices; one out of the next one hundred splices. The splice shall develop in tension or compression, as required, at least 125 percent of the specified yield strength of the bar as per Section 25.5.7.1 of ACI 318-19 and -14. For Type 2 splices, the splice shall develop at least 100 percent of the specified tensile strength of the steel reinforcing bar.

For Type 2 splices only, if failure of the tested splice should occur prior to obtaining the 125-percent of the specified yield strength and the 100-percent of the specified tensile strength, then 25 percent of all couplers shall be tested for both specified yield strength and specified tensile strength. If failure of the tested Type 2 splice occurs with testing of the 25 percent requirement, as stated above, then all couplers shall be rejected.

2.5 Minimum concrete cover and spacing between bars or sleeves shall be provided in accordance with Section 1808.8.2 of the 2023 LABC.

2.6 The Dayton Superior Mechanical Splice Systems for Steel Reinforcing Bars shall be installed in accordance with the applicable code, manufacturer's installation instructions, and this supplement. A copy of the manufacturer's installation instructions or specifications shall be available on-site for all Registered Deputy Inspectors.

2.7 Splice locations shall be noted on the plans approved by the building official. The plans and details shall be prepared, stamped, and signed by a California registered design professional, when required by the LABC or LARC.

2.8 Only qualified operators, specified by the manufacturer, completely familiar with the installation procedures and specifications shall perform the splicing.

2.9 This supplement expires concurrently with ER-319.

For additional information about this evaluation report please visit www.uniform-es.org or email us at info@uniform-es.org