



**THE  
POWER  
OF RED™**

**SYMONS® FORMWORK  
AND SHORING SYSTEMS  
CATALOG**

**CONCRETE  
CONSTRUCTION  
SOLUTIONS**



**SYMONS®**  
BY DAYTON SUPERIOR





**SYMONS**<sup>®</sup>  
BY DAYTON SUPERIOR

# CONCRETE FORM SYSTEMS

Symons<sup>®</sup> by Dayton Superior<sup>®</sup> offers an extensive and versatile line of forming systems to create the concrete foundations of most construction projects. These product lines feature innovative approaches that focus on adaptability, strength and labor savings. They range from pre-engineered cast-in-place systems to 100% custom factory-built products.

Adjustable Column .....	2
Aluminum Beam Gang .....	5
Flex-Form <sup>®</sup> .....	8
Max-A-Form <sup>®</sup> .....	12
Median Barrier and Parapet.....	18
Steel-Ply <sup>®</sup> .....	21
Sym-Ply <sup>®</sup> .....	27
Steel Round Column.....	31

## Adjustable Column Forms

Form almost any civil or commercial concrete column with this adjustable, all-steel form system.

The Adjustable Column concrete forming system is designed for square and rectangular columns up to 48" wide. Forming a variety of column dimensions using identical panels minimizes equipment, provides versatility and improves productivity.

### Heavy-Duty design

The strong 3/16" steel-faced system is built to stand up to the daily punishment of any commercial forming project. A design rating of 2000 pounds per square foot means faster pour rates and quicker changes.

### Column versatility

An extraordinary 295 column configurations are possible with 24", 36" and 48" widths and 1', 2', 4', 8' and 12' heights. The ability to form 10" to 48" square columns with a minimum of panels is a real equipment savings. Add the versatility to form rectangular configurations in 1" and 2" increments, and you have a truly efficient column forming system.

### Excellent finish

Unlike other column systems, Symons uses 3/16" steel plate for the forming surface. The heavier plate allows faster pour rates with less deflection, and produces a consistently excellent concrete finish. With no internal ties, Aluminum beam Gangs flush-fit hole plugs, and the built-in 3/4" chamfer, finishing operations are reduced significantly.



# CONCRETE FORM SYSTEMS



The adjustable column form is a durable, rugged system that quickly form column dimensions in 1" and 2" increments.

- 2000 psf allowable pressure
- Standard 3/4" chamfer on all columns create smooth edge finish
- 3/16" steel form face provides an excellent finish
- Standard 3/4" Speed Bolts join forms
- No internal ties required, up to 48" square columns

## CIVIL FORM PANELS

(For square and rectangular columns up to 48")

Product Code	Description	Weight
F38119	48" x 12' Civil Panel	924.00 LB
F38118	48" x 8' Civil Panel	635.00 LB
F38117	48" x 4' Civil Panel	351.00 LB
F38116	48" x 2' Civil Panel	217.00 LB
F38115	48" x 1' Civil Panel	139.00 LB
F38114	36" x 12' Civil Panel	709.00 LB
F38113	36" x 8' Civil Panel	487.00 LB
F38112	36" x 4' Civil Panel	265.00 LB
F38111	36" x 2' Civil Panel	165.00 LB
F38110	36" x 1' Civil Panel	104.00 LB

## COMMERCIAL FORM PANELS

(For square and rectangular columns up to 48")

Product Code	Description	Weight
F38109	36" x 12' Commercial Panel	689.00 LB
F38108	36" x 8' Commercial Panel	473.00 LB
F38107	36" x 4' Commercial Panel	257.00 LB
F38106	36" x 2' Commercial Panel	162.00 LB
F38105	36" x 1' Commercial Panel	101.00 LB
F38104	24" x 12' Commercial Panel	523.00 LB
F38103	24" x 8' Commercial Panel	358.00 LB
F38102	24" x 4' Commercial Panel	192.00 LB
F38101	24" x 2' Commercial Panel	117.00 LB
F38100	24" x 1' Commercial Panel	73.00 LB



## Adjustable Column Forms Adapt to Site Conditions

The MAPS Arena, in downtown Oklahoma City, is a professional hockey facility. The large complex can also accommodate other sporting events.

Faced with a multitude of concrete column heights and dimensions, the contractor was concerned about the cost of renting and storing many form sizes to form them all. To solve this problem, Symons by Dayton Superior suggested that the contractor consider using the Adjustable Column Form for most of these important elements. With these forms, columns with different dimensions can be formed with a minimum amount of equipment. These 2,000 psf forms can be adjusted incrementally to accommodate a wide variety of sizes without having to use internal ties.

Around the perimeter of the arena, a “T” shaped column was specified. These columns were consistently sized, reducing the form sizes required. However, opposite ends of the “T” needed to accommodate multiple rebar protrusions along the entire height of the column.

The plan for these columns was to use standard Max-A-Form components for all faces except the ones with rebar penetrations. These two ends utilized plywood reinforced by Steel-Ply Bulkhead Bars. Five-inch walers surrounded the forms on 4' centers to provide additional support.

The contractor praised the workability of each of these systems and the consistently excellent finish that they produced.



Adjustable Column Forms allow contractors to reconfigure the units and produce a variety of column dimensions with the same equipment.



Although the arena design featured columns of many different sizes, the concrete forming systems were easily adapted to each situation.

# CONCRETE FORM SYSTEMS

## Aluminum Beam Gangs

A strong, lightweight concrete forming system of beams and plywood for repetitive gangform applications.

### Lightweight design

Symons Aluminum Beam Gang offers an extremely high strength-to-weight forming system. The unique beam attachment clips, sturdy aluminum beams and steel walers combine to create a rigid, compact, and lightweight gangform system. The system is easy for crews to assemble, position and align.

### Application versatility

The Aluminum Beam Gang system can be used for virtually any concrete forming application. Unlike competitive aluminum gang form products that may suffice for simple straight walls, you can form corners, pilasters, core walls, curved walls, and other configurations with a complete line of accessories and transitions.

### Easy transitions

Transitions to other standard Symons forming systems make special forming conditions easy to complete. Contour-threaded hardware, available for use with the Aluminum Beam Gang, eliminates concrete buildup on important hardware items. These components are all designed to eliminate mishaps, reduce waste and maximize forming productivity.



## Aluminum Beam Gang, continued

Aluminum Beam Gang is adaptable for corners, pilasters, core walls, curved walls and other configurations.

- High strength-to-weight ratio
- Compact and light gangs
- Can be designed for specific pour pressures



### ATTACHMENT ACCESSORIES

Product Code	Description	Weight
F36502	Beam Attachment Clip	0.31 LB
F36508	Clamping Nut	0.10 LB
F36307	1/2"-13 NC x 1 1/2" Bolt	0.06 LB
F49971	1/2"-13 NC x 2 1/2" Bolt	0.10 LB
F36305	All Joist T-Bolt	0.10 LB

### GANG FORM ACCESSORIES

See Heavy Ties and Walers, Steel-Ply and Versiform sections for ties and other accessories for the Aluminum Beam Gang forming system

Product Code	Description	Weight
F36415	Rail Clasp	0.13 LB
F36416	Waler Lift Sleeve	0.84 LB
F33778	5/8" x 6" Contour Threaded Bolt	0.50 LB
F33151	Panel Waler Connector	2.50 LB
F31411	1/2" NC Nut	0.10 LB
F36085	5/8" Fit-Up Nut	0.07 LB
F31615	5/8" x 2" Fit-Up Bolt	0.22 LB
F40057	Versiform-to-Steel-Ply Transition Bolt	0.10 LB
F10852	Corewall Turnbuckle	0.00 LB
F60085	Corner Tie Bracket	3.40 LB
F36226	1/2" Flat Washer	0.10 LB



# CONCRETE FORM SYSTEMS

## Forming Raised to an Art Form

When the Milwaukee Art Museum announced their largest expansion project ever, Steven G. Chamberlin, President of CG Schmidt, wanted to build it. Steven was eager to work with Santiago Calatrava, whose fluid, dynamic designs and engineering talent commands worldwide attention, he also wanted the company to be involved in a project to enrich the community.

CG Schmidt is Milwaukee's largest General Contractor and construction management company. They were chosen for this project because of their extensive experience and their innovative approach to unusual construction situations. "This is a unique construction challenge. Our part is to manage the delicate balance between cost, quality, function and aesthetics as they're all interrelated," said Chamberlin.

The Milwaukee Art Museum expansion was the first Calatrava building in the United States. His design consists of a grand, translucent pavilion structure enclosed by light-controlling louvers which can be raised or lowered, creating a sculptural effect that has been likened to a bird in flight. The project also included a single-story galleria containing exhibition space and lecture hall, plus a suspended pedestrian bridge with a 200-foot-tall angled mast and cables that reflect the architect's experience in bridge design. Cast-in-place concrete is used extensively throughout the project, usually in unique curving configurations that create many forming challenges.

One of the forming challenges that CG Schmidt encountered was creating the retaining walls that lead to the underground parking structure. The walls were designed with a distinctive vertical twist that made bracing and support a concern.

Symons suggested that the contractor use the Aluminum Beam Gangs with Symons Soldier Beams as walers to gather the load and to provide the substantial bracing necessary.

The contractor reported that the forming solution worked great, and that breaking down the setup after the first pour and reassembling it in reverse for the second pour went smoothly.



The concrete retaining wall was designed with a 25° twist that posed some unusual forming and support challenges.



Symons Soldier was used as walers to carry the Taper Tie loads for the Aluminum Beam Gangs.

## Flex-Form® Forming System

A flexible forming system designed for round concrete tanks and curved walls.

### All-steel design

The all-steel Flex-Form system gives you all the strength and versatility of integral 4" deep vertical stiffeners with 3/16" steel skin plate in a system rated for 1000 pounds per square foot. Panels are available in 2', 3', 4', 5' and 6' widths, and 4', 8' and 12' lengths. The large number of sizes allows more forming flexibility. The right combination of panels mean fewer pieces, fewer panel joints and less labor to assemble.

### Pre-rolled ribs

Pre-rolled, factory-installed top and bottom steel ribs bolt to flexible panel sections to shape and hold the form to the radius. Panels always conform to the radius of the ribs, this design assures that you will get the correct radius every time. By installing a straight rib, you can even produce a straight form and wall when needed. Panels are shipped to the jobsite with factory-installed ribs so forming operations can begin almost immediately.

### Excellent finish

Because the steel skin plate flexes to form the desired arc, there's no "chording" appearance in the poured concrete surface. Conventional panel systems produce form joint marks that require grinding and rubbing, while the Flex-Form system produces smooth concrete surfaces that require practically no finishing.



# CONCRETE FORM SYSTEMS

## PANELS

Product Code	Description	Weight
F32112	6' W x 12' L FF Panel	1,012.00 LB
F32111	6' W x 8' L FF Panel	655.00 LB
F32110	6' W x 4' L FF Panel	367.00 LB
F32117	6' W x 12' L FF Pour Door Panel	1,275.78 LB
F32109	5' W x 12' L FF Panel	811.00 LB
F32108	5' W x 8' L FF Panel	528.00 LB
F32107	5' W x 4' L FF Panel	297.00 LB
F32106	4' W x 12' L FF Panel	650.00 LB
F32105	4' W x 8' L FF Panel	423.00 LB
F32104	4' W x 4' L FF Panel	238.00 LB
F32103	3' W x 12' L FF Panel	490.00 LB
F32102	3' W x 8' L FF Panel	319.00 LB
F32101	3' W x 4' L FF Panel	180.00 LB
F32115	3' x 12' FF Void Panel	450.00 LB
F32114	3' x 8' FF Void Panel	213.72 LB
F32113	3' x 4' FF Void Panel	128.50 LB
F32118	2' W x 12' L FF Panel	331.00 LB
F32119	2' W x 8' L FF Panel	214.00 LB
F32120	2' W x 4' L FF Panel	121.00 LB

## RIBS

1. Specify inside or outside concrete radius for rolled ribs.
2. Specify rib-to-Panel installation.
3. Rolled ribs less than 10' radius are "purchase only."

Product Code	Description	Weight
F32126	12' FF Inside Rolled Rib	102.00 LB
F32125	8' FF Inside Rolled Rib	68.00 LB
F32124	4' FF Inside Rolled Rib	34.00 LB
F32129	12' FF Outside Rolled Rib	102.00 LB
F32128	8' FF Outside Rolled Rib	68.00 LB
F32127	4' FF Outside Rolled Rib	34.00 LB
F32123	12' FF Straight Rib	102.00 LB
F32122	8' FF Straight Rib	68.00 LB
F32121	4' FF Straight Rib	34.00 LB



## FILLERS

Product Code	Description	Weight
F32156	8" x 6' FF Filler	86.80 LB
F32155	6" x 6' FF Filler	78.10 LB
F32154	4" x 6' FF Filler	69.40 LB
F32134	3" x 6' FF Filler	41.00 LB
F32153	2" x 6' FF Filler	60.10 LB
F32152	8" x 5' FF Filler	72.90 LB
F32151	6" x 5' FF Filler	65.50 LB
F32150	4" x 5' FF Filler	58.10 LB
F32133	3" x 5' FF Filler	38.00 LB
F32149	2" x 5' FF Filler	50.00 LB
F32148	8" x 4' FF Filler	59.00 LB
F32147	6" x 4' FF Filler	52.90 LB
F32146	4" x 4' FF Filler	46.70 LB
F32132	3" x 4' FF Filler	35.00 LB
F32145	2" x 4' FF Filler	40.00 LB
F32144	8" x 3' FF Filler	45.10 LB
F32143	6" x 3' FF Filler	40.30 LB
F32142	4" x 3' FF Filler	35.40 LB
F32131	3" x 3' FF Filler	30.00 LB
F32141	2" x 3' FF Filler	30.10 LB
F32140	8" x 2' FF Filler	0.00 LB
F32138	6" x 2' FF Filler	28.00 LB
F32139	4" x 2' FF Filler	0.00 LB
F32137	3" x 2' FF Filler	22.00 LB
F32136	2" x 2' FF Filler	20.60 LB

## FILLER ANGLE

Product Code	Description	Weight
F38556	6' MF Filler Angle	23.00 LB
F38555	5' MF Filler Angle	19.00 LB
F38554	4' MF Filler Angle	15.00 LB
F38553	3' MF Filler Angle	11.00 LB
F38552	2' MF Filler Angle	8.00 LB

## OUTSIDE CORNER ANGLES

Product Code	Description	Weight
F38256	6' MF Outside Corner Angle	43.20 LB
F38255	5' MF Outside Corner Angle	36.00 LB
F38254	4' MF Outside Corner Angle	28.80 LB
F38253	3' MF Outside Corner Angle	21.60 LB
F38252	2' MF Outside Corner Angle	14.40 LB

## Flex-Form, continued

### HIGH CAPACITY TIES

Product Code	Description	Weight
F32171	FF Tie Bearing Bracket	25.10 LB
F32181	FF Tie Bracket Angle	0.64 LB

### HARDWARE AND ACCESSORIES

Product Code	Description	Weight
F32173	FF Panel Aligner Plate	2.60 LB
F32175	FF Plywood Ext/Aligner Bracket	1.40 LB
F32172	FF Top Tie/Lift Bracket	8.60 LB
F32174	FF Waler Connector Channel	6.50 LB
F38062	MF Walkway Bracket	23.00 LB
F38061	MF Guard Rail Post	15.00 LB
F39916	12 Kip Anchor Clamp	36.00 LB
F39640	12 Kip Washer Plate	4.00 LB
F32176	FF Anchor Clamp Adaptor	11.03 LB
F39945	MF Thrust Bolt	5.90 LB
F32194	3/4" x 4" Speed Bolt	0.65 LB
F32195	3/4" x 3" Speed Bolt	0.60 LB
F32191	3/4" x 2" Speed Bolt	0.36 LB
F32193	3/4" Speed Nut	0.18 LB
F32177	FF Ladder Connector Bracket	9.60 LB
F35226	6' CF Ladder	69.00 LB
F35225	5' CF Ladder	57.00 LB
F35224	4' CF Ladder	48.00 LB
F35223	3' CF Ladder	40.00 LB
F35222	2' CF Ladder	32.00 LB
F32190	FF Special Holes to 2" (Rent)	0.70 P
F32189	FF Special Holes to 2" (Purchase)	0.70 P



# CONCRETE FORM SYSTEMS



Flex-Form provided the finish and form strength required for the job, and the contractor saved time and labor because the forms arrived on site with the 39' radius already set.



Pour doors allowed easy access for concrete placement on the 33' tall walls.

## Built-In Radius with Flex-Form is a Huge Advantage

When John Wegner, the owner of Municipal Builders, Inc., first contacted Symons about this project, he was looking for an easy-to-assemble system to provide the finish they needed on the high curved walls. He knew they would not be able to use the Steel-Ply forming system they already owned because of the wall height and finish requirements, so he needed to find something better suited to the application. After evaluating numerous options, he decided to use the Flex-Form forming system.

A major reason for choosing the Flex-Form system was the fact that the equipment arrived on the site with the radius already built into the formwork. Superintendent Jerry Adranes commented, "The fact that the forms came to my jobsite with the radius already built was a huge advantage. We saved about one week of labor with this system versus the other options." When asked what one thing he liked most about the system, Jerry said, "It was quick and easy to assemble. Once you had it together, it was very rigid. I wouldn't change a thing."

Municipal Builders, Inc. even discovered some additional benefits by using the 6'x12' Flex-Form Panels with Pour Doors. The built-in pour doors provided some extra light between gangs on the tall walls and, of course, multi-level access during concrete placement.

Municipal Builders, Inc. was very pleased with the outcome on this project, since the easy-to-assemble Flex-Form system gave them the ability to form this structure with less labor and complete the concrete ahead of schedule.

## Max-A-Form® STS Forming System

Superior pour pressure and moment capacities result in labor and material savings for the end user.

The Max-A-Form STS forming system is the industry leader in rentable, self-spanning, steel formwork. The all-steel, welded frame makes it the ideal choice for gang forming tall structural walls, pouring tieless columns, or for supporting concrete over long spans without shoring or custom equipment. The proprietary design and manufacturing process result in a superior finish, pour after pour.

### Panel Design

Max-A-Form STS panels are constructed with a 1/4" steel face plate, heavy duty crossmembers, and a continuous back-up flat that supports higher pour rates. Panels up to 8' wide by 20' long are rated at 2000 psf; 9' wide panels are rated for 1,700 psf, 10' wide panels are rated at 1600 psf, and 12' wide panels are rated at 1300 psf. The design of the STS panel results in a "no pillow" concrete surface at rated loads. In addition, the rigidity of these panels virtually eliminates waler or strongback requirements and reduces the number of ties required.

### Max-A-Form STS Compatibility

STS panels are designed to allow the use of existing Max-A-Form accessories, including: Combination Rigid Corners, Inside Stripping Corners, Walkway Brackets, Wind Beams, Top and Bottom Ties, Anchor Brackets, Swivel Screw Jacks and many other standard products.

### Self-Spanning

The strong, deep frame design with 1/4" steel face results in superior moment (self-spanning) capacities. Max-A-Form STS provides moment capacities 30% higher than previous Max-A-Form and similar competitive systems. This means little or no shoring or custom equipment that slow cycling times.

Stability Beams and Pier Cap Braces, Spreader Beams, Top Tie/Lift Brackets, Bottom Ties with Swivel Screw Jacks, Walkway Brackets and other accessories are available for self-spanning applications.

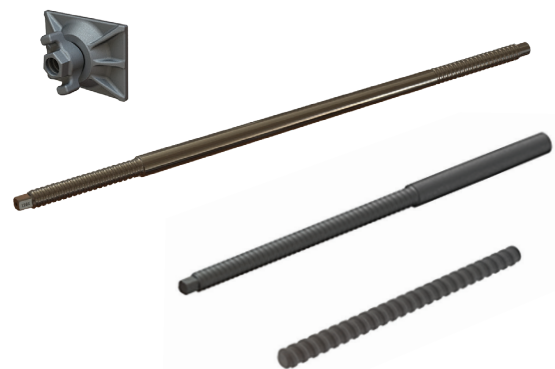

# CONCRETE FORM SYSTEMS

Experience superior strength, finish, durability and savings with Max-A-Form STS. This all-steel form system is ideal for large columns and tall walls. As the Industry leader in rentable, self-spanning steel formwork, Max-A-Form STS can be a true asset when large transfer girders are present in Mezzanine and other long spanning areas of a structure. The 2,000 psf pour pressure and superior moment capacities result in labor and material savings for the end user. The proprietary design and manufacturing process result in a smooth finish, pour after pour.

## 12 FT MAX-A-FORM STS PANELS

Product Code	Description	Weight
F1401208	12' W x 8' L MAF STS Panel	2,415.40 LB
F1401207	12' W x 7' L MAF STS Panel	2,142.00 LB
F1401206	12' W x 6' L MAF STS Panel	1,869.80 LB
F1401205	12' W x 5' L MAF STS Panel	1,620.00 LB
F1401204	12' W x 4' L MAF STS Panel	1,324.30 LB
F1401203	12' W x 3' L MAF STS Panel	1,054.00 LB
F1401202	12' W x 2' L MAF STS Panel	742.80 LB
F1401201	12' W x 1' L MAF STS Panel	432.50 LB



## 10 FT MAX-A-FORM STS PANELS

Product Code	Description	Weight
F1401020	10' W x 20' L MAF STS Panel	4,200.00 LB
F1401012	10' W x 12' L MAF STS Panel	2,698.40 LB
F1401010	10' W x 10' L MAF STS Panel	2,200.00 LB
F1401008	10' W x 8' L MAF STS Panel	1,833.20 LB
F1401007	10' W x 7' L MAF STS Panel	1,645.00 LB
F1401006	10' W x 6' L MAF STS Panel	1,440.00 LB
F1401005	10' W x 5' L MAF STS Panel	1,225.00 LB
F1401004	10' W x 4' L MAF STS Panel	996.10 LB
F1401003	10' W x 3' L MAF STS Panel	784.70 LB
F1401002	10' W x 2' L MAF STS Panel	549.20 LB
F1401001	10' W x 1' L MAF STS Panel	312.30 LB

## 8 FT MAX-A-FORM STS PANELS

Product Code	Description	Weight
F1400820	8' W x 20' L MAF STS Panel	3,280.00 LB
F1400812	8' W x 12' L MAF STS Panel	2,009.20 LB
F1400810	8' W x 10' L MAF STS Panel	1,700.00 LB
F1400808	8' W x 8' L MAF STS Panel	1,371.20 LB
F1400807	8' W x 7' L MAF STS Panel	1,232.00 LB
F1400806	8' W x 6' L MAF STS Panel	1,080.00 LB
F1400805	8' W x 5' L MAF STS Panel	920.00 LB
F1400804	8' W x 4' L MAF STS Panel	761.50 LB
F1400803	8' W x 3' L MAF STS Panel	600.00 LB
F1400802	8' W x 2' L MAF STS Panel	428.40 LB
F1400801	8' W x 1' L MAF STS Panel	248.10 LB

## 6 FT MAX-A-FORM STS PANELS

Product Code	Description	Weight
F1400620	6' W x 20' L MAF STS Panel	2,660.40 LB
F1400612	6' W x 12' L MAF STS Panel	1,437.60 LB
F1400610	6' W x 10' L MAF STS Panel	1,200.00 LB
F1400608	6' W x 8' L MAF STS Panel	979.20 LB
F1400607	6' W x 7' L MAF STS Panel	870.50 LB
F1400606	6' W x 6' L MAF STS Panel	760.30 LB
F1400605	6' W x 5' L MAF STS Panel	660.00 LB
F1400604	6' W x 4' L MAF STS Panel	541.50 LB
F1400603	6' W x 3' L MAF STS Panel	432.50 LB
F1400602	6' W x 2' L MAF STS Panel	301.80 LB
F1400601	6' W x 1' L MAF STS Panel	172.10 LB

## 9 FT MAX-A-FORM STS PANELS

Product Code	Description	Weight
F1400920	9' W x 20' L MAF STS Panel	4,052.30 LB
F1400912	9' W x 12' L MAF STS Panel	2,291.00 LB
F1400910	9' W x 10' L MAF STS Panel	1,946.00 LB
F1400908	9' W x 8' L MAF STS Panel	1,675.40 LB
F1400907	9' W x 7' L MAF STS Panel	1,433.00 LB
F1400906	9' W x 6' L MAF STS Panel	1,256.00 LB
F1400905	9' W x 5' L MAF STS Panel	1,069.00 LB
F1400904	9' W x 4' L MAF STS Panel	1,002.70 LB
F1400903	9' W x 3' L MAF STS Panel	689.00 LB
F1400902	9' W x 2' L MAF STS Panel	501.20 LB
F1400901	9' W x 1' L MAF STS Panel	282.50 LB

## 7 FT MAX-A-FORM STS PANELS

Product Code	Description	Weight
F1400720	7' W x 20' L MAF STS Panel	2,660.40 LB
F1400712	7' W x 12' L MAF STS Panel	1,623.80 LB
F1400710	7' W x 10' L MAF STS Panel	1,375.20 LB
F1400708	7' W x 8' L MAF STS Panel	1,105.60 LB
F1400707	7' W x 7' L MAF STS Panel	980.00 LB
F1400706	7' W x 6' L MAF STS Panel	861.00 LB
F1400705	7' W x 5' L MAF STS Panel	735.00 LB
F1400704	7' W x 4' L MAF STS Panel	608.40 LB
F1400703	7' W x 3' L MAF STS Panel	483.00 LB
F1400702	7' W x 2' L MAF STS Panel	338.90 LB
F1400701	7' W x 1' L MAF STS Panel	194.20 LB

## 5 FT MAX-A-FORM STS PANELS

Product Code	Description	Weight
F1400520	5' W x 20' L MAF STS Panel	1,900.00 LB
F1400512	5' W x 12' L MAF STS Panel	1,124.00 LB
F1400510	5' W x 10' L MAF STS Panel	950.00 LB
F1400508	5' W x 8' L MAF STS Panel	770.00 LB
F1400507	5' W x 7' L MAF STS Panel	691.25 LB
F1400506	5' W x 6' L MAF STS Panel	637.50 LB
F1400505	5' W x 5' L MAF STS Panel	537.50 LB
F1400504	5' W x 4' L MAF STS Panel	437.00 LB
F1400503	5' W x 3' L MAF STS Panel	345.00 LB
F1400502	5' W x 2' L MAF STS Panel	251.20 LB
F1400501	5' W x 1' L MAF STS Panel	146.00 LB

# Max-A-Form STS Forming System, continued

## 4 FT MAX-A-FORM STS PANELS

Product Code	Description	Weight
F1400420	4' W x 20' L MAF STS Panel	1,600.00 LB
F1400412	4' W x 12' L MAF STS Panel	950.50 LB
F1400410	4' W x 10' L MAF STS Panel	800.00 LB
F1400408	4' W x 8' L MAF STS Panel	650.70 LB
F1400407	4' W x 7' L MAF STS Panel	594.00 LB
F1400406	4' W x 6' L MAF STS Panel	516.00 LB
F1400405	4' W x 5' L MAF STS Panel	440.00 LB
F1400404	4' W x 4' L MAF STS Panel	372.00 LB
F1400403	4' W x 3' L MAF STS Panel	300.00 LB
F1400402	4' W x 2' L MAF STS Panel	211.80 LB
F1400401	4' W x 1' L MAF STS Panel	121.80 LB

## 3 FT 6 MAX-A-FORM STS PANELS

Product Code	Description	Weight
F1403608	3'6" W x 8' L MAF STS Panel	592.50 LB
F1403604	3'6" W x 4' L MAF STS Panel	341.00 LB
F1403603	3'6" W x 3' L MAF STS Panel	267.75 LB
F1403602	3'6" W x 2' L MAF STS Panel	194.40 LB
F1403601	3'6" W x 1' L MAF STS Panel	111.20 LB

## 3 FT MAX-A-FORM STS PANELS

Product Code	Description	Weight
F1400320	3' W x 20' L MAF STS Panel	1,260.00 LB
F1400312	3' W x 12' L MAF STS Panel	777.60 LB
F1400310	3' W x 10' L MAF STS Panel	657.00 LB
F1400308	3' W x 8' L MAF STS Panel	532.20 LB
F1400307	3' W x 7' L MAF STS Panel	483.00 LB
F1400306	3' W x 6' L MAF STS Panel	432.00 LB
F1400305	3' W x 5' L MAF STS Panel	375.00 LB
F1400304	3' W x 4' L MAF STS Panel	308.60 LB
F1400303	3' W x 3' L MAF STS Panel	243.00 LB
F1400302	3' W x 2' L MAF STS Panel	175.90 LB
F1400301	3' W x 1' L MAF STS Panel	100.00 LB

## 2 FT 6 MAX-A-FORM STS PANELS

Product Code	Description	Weight
F1402608	2'6" W x 8' L MAF STS Panel	468.60 LB
F1402604	2'6" W x 4' L MAF STS Panel	272.50 LB
F1402603	2'6" W x 3' L MAF STS Panel	217.50 LB
F1402602	2'6" W x 2' L MAF STS Panel	153.30 LB
F1402601	2'6" W x 1' L MAF STS Panel	88.60 LB

## 2 FT MAX-A-FORM STS PANELS

Product Code	Description	Weight
F1400212	2' W x 12' L MAF STS Panel	600.60 LB
F1400208	2' W x 8' L MAF STS Panel	408.60 LB
F1400207	2' W x 7' L MAF STS Panel	364.00 LB
F1400206	2' W x 6' L MAF STS Panel	326.90 LB
F1400205	2' W x 5' L MAF STS Panel	280.00 LB
F1400204	2' W x 4' L MAF STS Panel	240.10 LB
F1400203	2' W x 3' L MAF STS Panel	192.00 LB
F1400202	2' W x 2' L MAF STS Panel	134.90 LB
F1400201	2' W x 1' L MAF STS Panel	74.60 LB

## MAX-A-FORM STS OUTSIDE CORNERS

Product Code	Description	Weight
F1401252	12' MAF STS Outside Corner Angle	153.47 LB
F1401250	10' MAF STS Outside Corner Angle	127.87 LB
F1401249	9' MAF STS Outside Corner Angle	115.07 LB
F1401248	8' MAF STS Outside Corner Angle	102.27 LB
F1401247	7' MAF STS Outside Corner Angle	89.47 LB
F1401246	6' MAF STS Outside Corner Angle	76.67 LB
F1401245	5' MAF STS Outside Corner Angle	63.87 LB
F1401244	4' MAF STS Outside Corner Angle	51.07 LB
F1401243	3' MAF STS Outside Corner Angle	38.27 LB
F1401242	2' MAF STS Outside Corner Angle	25.47 LB
F1401241	1' MAF STS Outside Corner Angle	12.67 LB

## MAX-A-FORM STS HARDWARE

Product Code	Description	Weight
F1409000	1" x 4" Girder Bolt (A490)	1.08 LB
F31633	1" Girder Nut (2H)	0.41 LB
F1409100	Max-A-Form Handling Hook	4.40 LB

## MAX-A-FORM STS SUPER TAPER TIES

### SHE-BOLT AND INSIDE RODS

Product Code	Description	Weight
145402	32mm x 30" 112K She-Bolt with 26mm Inside Thread	10.50 LB
145429	26mm x 5'-0" Long 128K Inside Rod	2.67 LB/FT
145430	26mm x 12'-0" Long 112K Inside Rod	2.67 LB/FT

### 128 K TAPER TIES

Product Code	Description	Weight
145248	44" 128 K Taper Tie 1.5" to 1.25"	15.70 LB
145249	54" 128 K Taper Tie 1.5" to 1.25"	19.80 LB
145250	64" 128 K Taper Tie 1.5" to 1.25"	24.00 LB
145251	74" 128 K Taper Tie 1.5" to 1.25"	28.10 LB
145252	84" 128 K Taper Tie 1.5" to 1.25"	32.10 LB
145181	32mm Swivel Wing Nut with 5" x 7" plate	7.09 LB



# CONCRETE FORM SYSTEMS

## Max-A-Form Inside and Outside Corners COMBINATION RIGID CORNER HALVES (DOUBLE DUTY)

Product Code	Description	Weight
F39050	10' x 1' MF Combination Rigid Corner DD	211.28 LB
F39049	9' x 1' MF Combination Rigid Corner DD	193.05 LB
F39048	8' x 1' MF Combination Rigid Corner DD	169.06 LB
F39047	7' x 1' MF Combination Rigid Corner DD	151.10 LB
F39046	6' x 1' MF Combination Rigid Corner DD	132.18 LB
F39045	5' x 1' MF Combination Rigid Corner DD	113.96 LB
F39044	4' x 1' MF Combination Rigid Corner DD	95.76 LB
F39043	3' x 1' MF Combination Rigid Corner DD	77.54 LB
F39042	2' x 1' MF Combination Rigid Corner DD	53.09 LB

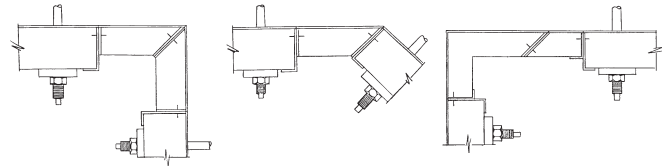

COMBINATION RIGID CORNER - DOUBLE DUTY

INSIDE STRIPPING CORNER - DOUBLE DUTY

### INSIDE STRIPPING CORNERS (DOUBLE DUTY)

Product Code	Description	Weight
F39083	10' MF Corner Section DD	379.26 LB
F39082	9' MF Corner Section DD	356.50 LB
F39051	8' MF Corner Section DD	301.76 LB
F39081	7' MF Corner Section DD	268.67 LB
F39052	6' MF Corner Section DD	235.34 LB
F39080	5' MF Corner Section DD	202.00 LB
F39053	4' MF Corner Section DD	168.66 LB
F39054	3' MF Corner Section DD	135.33 LB
F39055	2' MF Corner Section DD	90.41 LB
F39064	10' MF Stripping Section DD	176.55 LB
F39063	9' MF Stripping Section DD	167.02 LB
F39056	8' MF Stripping Section DD	140.96 LB
F39062	7' MF Stripping Section DD	125.93 LB
F39057	6' MF Stripping Section DD	110.88 LB
F39061	5' MF Stripping Section DD	95.85 LB
F39058	4' MF Stripping Section DD	80.80 LB
F39059	3' MF Stripping Section DD	65.87 LB
F39060	2' MF Stripping Section DD	45.21 LB

### OUTSIDE CORNER ANGLES

Product Code	Description	Weight
F38262	12' MF Outside Corner Angle	86.40 LB
F38260	10' MF Outside Corner Angle	72.00 LB
F38259	9' MF Outside Corner Angle	64.80 LB
F38258	8' MF Outside Corner Angle	57.60 LB
F38257	7' MF Outside Corner Angle	50.40 LB
F38256	6' MF Outside Corner Angle	43.20 LB
F38255	5' MF Outside Corner Angle	36.00 LB
F38254	4' MF Outside Corner Angle	28.80 LB
F38253	3' MF Outside Corner Angle	21.60 LB
F38252	2' MF Outside Corner Angle	14.40 LB
F38251	1' MF Outside Corner Angle	7.20 LB

## Max-A-Form Angles and Cover Plates LAP ANGLES

Product Code	Description	Weight
F38278	12' MF Lap Angle	81.55 LB
F38970	10' MF Lap Angle	72.00 LB
F38971	9' MF Lap Angle	64.80 LB
F38277	8' MF Lap Angle	54.39 LB
F38972	7' MF Lap Angle	50.00 LB
F38973	6' MF Lap Angle	43.20 LB
F38276	5' MF Lap Angle	34.01 LB
F38275	4' MF Lap Angle	27.47 LB
F38974	3' MF Lap Angle	21.60 LB
F38975	2' MF Lap Angle	14.40 LB
F38976	1' MF Lap Angle	7.20 LB

### FILLER ANGLES

Product Code	Description	Weight
F38562	12' MF Filler Angle	46.00 LB
F38560	10' MF Filler Angle	38.00 LB
F38559	9' MF Filler Angle	34.00 LB
F38558	8' MF Filler Angle	31.00 LB
F38557	7' MF Filler Angle	27.00 LB
F38556	6' MF Filler Angle	23.00 LB
F38555	5' MF Filler Angle	19.00 LB
F38554	4' MF Filler Angle	15.00 LB
F38553	3' MF Filler Angle	11.00 LB
F38552	2' MF Filler Angle	8.00 LB
F38551	1' MF Filler Angle	4.00 LB

### COVER PLATES

Product Code	Description	Weight
F39635	8" x 3/4" MF Cover Plate x 20'	408.00 LB
F39636	8" x 3/4" MF Splice Plate	36.00 LB
F39633	6" x 3/4" MF Cover Plate x 20'	306.00 LB
F39634	6" x 3/4" MF Splice Plate	27.00 LB
F39632	3/4" x 3" A325 Machine Bolt	0.48 LB
F43921	3/4" A325 Machine Hex Nut	0.19 LB
F32195	3/4" x 3" Speed Bolt	0.60 LB
F32193	3/4" Speed Nut	0.18 LB

## Max-A-Form STS Forming System, continued

### Max-A-Form Top and Bottom Ties

#### TOP TIES

Product Code	Description	Weight
F39934	9' Top Tie	50.60 LB
F39933	6' Top Tie	33.60 LB
F39918	3' Top Tie	17.21 LB
F39932	Hinge Top Tie	26.00 LB

#### BOTTOM TIES

Product Code	Description	Weight
F39921	10L Bottom Tie	204.00 LB
F39922	10R Bottom Tie	204.00 LB
F39923	8L Bottom Tie	117.00 LB
F39924	8R Bottom Tie	117.00 LB
F39925	6L Bottom Tie	80.00 LB
F39926	6R Bottom Tie	80.00 LB
F39927	5L Bottom Tie	59.00 LB
F39928	5R Bottom Tie	59.00 LB
F39929	4L Bottom Tie	47.00 LB

### Max-A-Form Screw Jacks

#### JACKS

Product Code	Description	Weight
F39886	Long Swivel Screw Jack	18.43 LB
F39939	Swivel Screw Jack Bracket	24.00 LB
F39937	6' Jack Extension Tube	66.00 LB
F39938	3' Jack Extension Tube	36.00 LB
F39936	Extension Tube Bracket	22.00 LB
F39941	48" Rigid Screw Jack	30.20 LB
F39942	36" Rigid Screw Jack	24.20 LB
F39943	24" Rigid Screw Jack	18.20 LB
F39931	Bottom Tie Spacer	10.00 LB



### Max-A-Form Wind Beams and Bracing

#### WIND BEAMS

Product Code	Description	Weight
F39948	20' Stability Beam	640.00 LB
F39949	12' Stability Beam	386.00 LB
F39947	MF Clip Angle	4.30 LB
F39945	MF Thrust Bolt	5.90 LB
F39741	Stability Beam Connector 8-1/2"	17.00 LB
F39740	Stability Beam Connector 6-1/2"	13.00 LB
F39980	85-1/2" Brace	46.15 LB
F39979	67-1/2" Brace	42.00 LB
F39982	92" Extension	27.00 LB
F39981	56" Extension	15.72 LB
F39641	Heavy Duty Brace Bracket	38.00 LB
F39642	Heavy Duty Shoe	12.00 LB

#### BRACING

Product Code	Description	Weight
F40280	Adjustable Brace - Type I	23.00 LB
F40281	Adjustable Brace - Type II	35.00 LB
F40282	Adjustable Brace - Type III	50.00 LB
F40283	Ratchet Brace - Type I	38.00 LB
F40284	Ratchet Brace - Type II	50.00 LB
F40285	Ratchet Brace - Type III	65.00 LB
F40286	Diagonal Strut "A"	27.00 LB
F40287	Diagonal Strut "B"	74.00 LB
F38914	Soldier Attachment Angle MF	4.10 LB

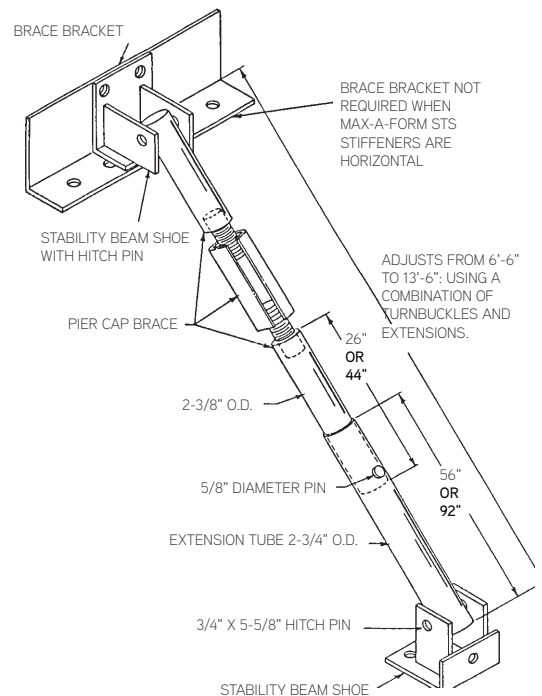

# CONCRETE FORM SYSTEMS

## Max-A-Form Bridges the Gap

Cold Spring Construction Company, located in Akron, New York, has built roads and bridges since 1911. They have owned Steel-Ply, Max-A-Form and other Symons forming systems for many of those years.

The contractor was awarded the \$18 million contract to build a 10-mile stretch of 4-lane highway located in Mansfield, Pennsylvania.

The project included four simple span bridges and one four-span bridge which needed to be completed on a tight schedule.

Project Superintendent and Manager Ted Walker planned to utilize Steel-Ply for the twenty-five footings required for this project, and gangs of horizontal Steel-Ply with 5" Versiform® walers to form the abutments. His experience showed that the load-gathering capabilities of this combination saves time and labor by providing quick gang setup and breakdown and reducing the number of ties and labor associated with them.

The 4-span structure consisted of two abutments and three piers. Each bridge bent consisted of one 60' long x 30' high base, three circular columns, 4'-6" diameter and 20' high and one cap beam 5'-6" wide x 6' high x 60' long. Staying on schedule for the entire project required that the schedule be very aggressive for this structure, so the contractor wanted to construct several elements simultaneously.

After evaluating their concrete forming needs, the contractor called on Symons to "bridge the gap" for them by providing additional Max-A-Form inventory to help them achieve their goal.

With forms for the pier bases and additional equipment for two pier caps provided by Symons by Dayton Superior, Cold Spring was able to construct one pier base, two sets of columns and two pier caps at the same time to meet the project deadline.



Many years of experience in bridge construction taught Cold Spring Construction that building several elements at once speeds the job.



The contractor supplemented their Max-A-Form inventory with additional rental equipment.

## Median Barrier And Parapet Systems

Cast-in-place, inverted or precast forms for median barriers or parapets.

### Symons cast-in-place design

Symons cast-in-place Median Barrier and Parapet forms are designed to conform to the standard 32" high "Jersey Style" contour.

Available in 5' or 10' standard lengths, these all-steel units can be furnished as an assembly or in component parts, depending on your specific requirements.

Adjustable top ties for standard forming operations or an adjustable yoke with tieless design and single-unit-stripping, have a range of top widths from 6" to 14" in 1" increments, providing versatility for almost every median barrier project.

### Inverted design

Symons also provides Median Barrier forms for conventional inverted casting or very productive rollover casting. The all-steel design withstands the demands of repetitive casting operations, producing a smooth and accurate shape every time.

Standard flat bulkheads are available for conventional inverted casting, while an adjustable trunnion bulkhead is utilized for more productive rollover operations.

### Precast design

Precast barrier forms conform to the standard 32" high "Jersey Style" contour and are available in standard 10' or 12' lengths. Units may be bolted together to create even longer barriers and lateral span rails may be added to support blockouts.

Whether your application is standard or special, Symons can furnish a system suited to your precast concrete operations.



# CONCRETE FORM SYSTEMS

Symons cast-in-place and precast Median Barrier and Parapet forms are designed to conform to the standard 32" high "Jersey-Style" contour. These can be furnished as an assembly or in component parts, depending on your specific requirements.

## 10 Ft Median Barrier Assemblies

### 32" HIGH X 10 FT MEDIAN BARRIER FORM WITH ADJUSTABLE YOKES.

(NO TIES REQUIRED)

Includes the following equipment:

- (2) 32" median barrier panels
- (2) adjustable yokes (6"-14" wide in 1" increments)
- (2) short grading bolts
- (25) 3/4" x 2" Speed Bolts and Nuts

Product Code	Description	Weight
F40650	Type A	794.75 LB
F40651	Type B	794.75 LB
F47238	Type F	826.96 LB

### 32" HIGH X 10 FT PARAPET FORM WITH ADJUSTABLE YOKES.

(NO TIES REQUIRED)

Includes the following equipment:

- (1) 32" median barrier panel
- (1) 32" parapet panel
- (2) adjustable yokes (6"-14" wide in 1" increments)
- (1) short grading bolt
- (1) long grading bolt
- (25) 3/4" x 2" Speed Bolts and Nuts

Product Code	Description	Weight
F40652	Type A	775.00 LB
F40653	Type B	775.00 LB
F47244	Type F	834.30 LB

### 32" HIGH X 10 FT MEDIAN BARRIER FORM WITH ADJUSTABLE TOP TIES.

(REQUIRES TWO BOTTOM TIES, NOT INCLUDED)

Includes the following equipment:

- (2) 32" median barrier panels
- (2) adjustable yokes (6"-14" wide in 1" increments)
- (2) short grading bolts
- (12) 3/4" x 2" Speed Bolts and Nuts

Product Code	Description	Weight
F40654	Type A	696.00 LB
F40655	Type B	641.00 LB
F47245	Type F	708.30 LB

## 10 Ft Parapet Assemblies

### 32" HIGH X 10 FT PARAPET FORM WITH ADJUSTABLE TOP TIES.

(REQUIRES TWO BOTTOM TIES, NOT INCLUDED)

Includes the following equipment:

- (1) 32" median barrier panel
- (1) 32" parapet panel
- (2) adjustable top ties (6"-14" wide in 1" increments)
- (1) short grading bolt
- (1) long grading bolt
- (12) 3/4" x 2" Speed Bolts and Nuts

Product Code	Description	Weight
F40656	Type A	717.00 LB
F40657	Type B	621.00 LB
F47246	Type F	717.30 LB

## 5 Ft Median Barrier / Parapet Assemblies

### 32" HIGH X 5 FT MEDIAN BARRIER FORM WITH ADJUSTABLE YOKES.

(NO TIES REQUIRED)

Includes the following equipment:

- (2) 32" median barrier panels
- (1) adjustable yoke (6"-14" wide in 1" increments)
- (2) short grading bolts
- (15) 3/4" x 2" Speed Bolts and Nuts

Product Code	Description	Weight
F40658	Type A	418.00 LB
F40659	Type B	418.00 LB
F47247	Type F	420.00 LB

### 32" HIGH X 5 FT PARAPET FORM WITH ADJUSTABLE YOKES.

(NO TIES REQUIRED)

Includes the following equipment:

- (1) 32" median barrier panel
- (1) 32" parapet panel
- (1) adjustable yokes (6"-14" wide in 1" increments)
- (1) short grading bolt
- (1) long grading bolt
- (15) 3/4" x 2" Speed Bolts and Nuts

Product Code	Description	Weight
F40660	Type A	400.00 LB
F40661	Type B	400.00 LB
F47232	Type F	425.11 LB

### 32" HIGH X 5 FT MEDIAN BARRIER FORM WITH ADJUSTABLE TOP TIES

(REQUIRES ONE BOTTOM TIE, NOT INCLUDED)

Includes the following equipment:

- (2) 32" median barrier panels
- (1) adjustable top tie (6"-14" wide in 1" increments)
- (2) short grading bolts
- (8) 3/4" x 2" Speed Bolts and Nuts

Product Code	Description	Weight
F40662	Type A	341.00 LB
F40663	Type B	341.00 LB
F47233	Type F	361.30 LB

### 32" HIGH X 5 FT PARAPET FORM WITH ADJUSTABLE TOP TIES

(REQUIRES ONE BOTTOM TIE, NOT INCLUDED)

Includes the following equipment:

- (1) 32" median barrier panel
- (1) 32" parapet panel
- (1) adjustable yokes (6"-14" wide in 1" increments)
- (1) short grading bolt
- (1) long grading bolt
- (8) 3/4" x 2" Speed Bolts and Nuts

Product Code	Description	Weight
F40664	Type A	323.00 LB
F40665	Type B	323.00 LB
F47252	Type F	362.30 LB

### STANDARD MEDIAN BARRIER PANELS 32" HIGH MEDIAN BARRIER FORMS

(ONE SIDE ONLY)

Product Code	Description	Weight
F40671	32" x 10'- 0" Long Type A (10" Radius)	298.00 LB
F40672	32" x 5'- 0" Long Type A (10" Radius)	158.00 LB
F40673	32" x 10'- 0" Long Type B (Bent)	298.00 LB
F40674	32" x 5'- 0" Long Type B (Bent)	158.00 LB
F47239	32" x 10'- 0" Long Type F	316.12 LB
F47248	32" x 5'- 0" Long Type F	164.90 LB

### STANDARD MEDIAN BARRIER PANELS 32" FLAT FACE PARAPET FORMS

(ONE SIDE ONLY)

Product Code	Description	Weight
F40675	32" x 10'- 0" Long	275.00 LB
F40676	32" x 5'- 0" Long	137.00 LB

## Median Barriers and Parapets, continued

### Median Barrier / Parapet Yokes and Top Ties

#### ADJUSTABLE YOKE

Product Code	Description	Weight
F40677	Adjustable Yoke Assembly	89.00 LB

#### ADJUSTABLE TOP TIE

Product Code	Description	Weight
F40678	Adjustable Top Tie Assembly	17.00 LB

### Median Barrier / Parapet Accessories

#### EXTERNAL BULKHEADS

External bulkhead consists of a 3/16" steel end plate bolted to the end of a median barrier form or parapet form. Single product code covers all sizes up to maximum "W" = 14". "W" is width dimension at top of barrier or parapet. Quantity under product code is for one (1) bulkhead.

Product Code	Description	Weight
F40685	Ext Bulkhead-Barrier	74.00 LB
F40686	Ext Bulkhead-Parapet	65.00 LB

#### BOLTS

Product Code	Description	Weight
F40680	3/4" x 36" Speed Bolt	4.00 LB
F32194	3/4" x 4" Speed Bolt	0.65 LB
F32191	3/4" x 2" Speed Bolt	0.36 LB
F32193	3/4" Speed Nut	0.18 LB



## Precast Median Barrier Forms

### 32" HIGH—TYPE A (10" RADIUS) BARRIER FORM

Product Code	Description	Weight
F31903	32" x 10'- 0" Long x 6" Top	1,059.00 LB
F31904	32" x 10'- 0" Long x 12" Top	1,156.00 LB
F31905	32" x 12'- 0" Long x 6" Top	1,280.00 LB
F31906	32" x 12'- 0" Long x 12" Top	1,375.00 LB

### 32" HIGH—TYPE B (BENT) BARRIER FORM

Product Code	Description	Weight
F31907	32" x 10'- 0" Long x 6" Top	1,075.00 LB
F31908	32" x 10'- 0" Long x 12" Top	1,155.00 LB
F31909	32" x 12'- 0" Long x 6" Top	1,280.00 LB
F31910	32" x 12'- 0" Long x 12" Top	1,375.00 LB

### 32" HIGH-TYPE F BARRIER FORM

Product Code	Description	Weight
F47253	32" x 10'- 0" Long x 6" Top	1,210.00 LB
F47257	32" x 10'- 0" Long x 12" Top	1,260.00 LB
F47259	32" x 12'- 0" Long x 6" Top	1,475.00 LB

Product Code	Description	Weight
F47261	32" x 12'- 0" Long x 12" Top	1,525.00 LB

#### MEDIAN BARRIER SUPPORT ANGLE

Product Code	Description	Weight
F47736	Median Barrier Support Angle w/ 6" Top	15.00 LB
F47737	Median Barrier Support Angle w/ 12" Top	11.32 LB

### Rollover Bulkheads for Precast Forms

#### ADJUSTABLE TRUNNION BULKHEADS

Product Code	Description	Weight
F31913	32" High x 6" Top Assembly	150.00 LB
F31916	32" High x 6" Top w/o 31915	121.80 LB
F31915	Adj Trunnion Pin	19.00 LB
F31914	32" High x 12" Top Assembly	172.70 LB
F31917	32" High x 12" Top w/o 31915	151.20 LB



# CONCRETE FORM SYSTEMS

## Steel-Ply® Forming System

The most productive, pre-engineered, factory-built, reusable concrete forming system in use today.

The Steel-Ply forming system may be used in handset or gang form applications, for commercial or residential structures, to form walls of almost any shape or size.

### Forming productivity

The Steel-Ply system is more productive and economical than job-built lumber and plywood formwork. No measuring, sawing, drilling, or nailing is required. Minimal training is needed, so workers are quickly up to maximum efficiency with only a hammer needed for setup and stripping.

### Application flexibility

Unlike job-built formwork, which must be tailored for each specific pour, the Steel-Ply forming system comes in a variety of standard sizes which can be combined to form virtually any dimension. Steel-Ply panels and fillers are made of specially laminated plywood mounted to rugged steel frames. With proper care, Steel-Ply forms can be used up to 200 times before being reconditioned.

### Consistent results

No matter what the forming application, the same basic components and methods are used. Labor performance becomes consistent and predictable, saving time and money on concrete forming operations.



The Symons Steel-Ply concrete forming system came into the market in 1955 and has not been surpassed. Its staying power is proven by being the most widely used and recognized form system in the market today! This versatile, hand-set system can be used on virtually any type of vertical concrete structure including; foundation walls, columns, shear walls, slab edges, elevator shafts and stair cores. The Steel-Ply system now features a 1/2" 200/200 7-ply PSF Birch plywood engineered specifically for Symons.



**10' EQUIPMENT\***

Product Code	Description	Weight
F11024	24" x 10' Panel	95.98 LB
F11022	22" x 10' Filler	93.00 LB
F11020	20" x 10' Filler	85.13 LB
F11018	18" x 10' Filler	79.00 LB
F11016	16" x 10' Filler	74.00 LB
F11014	14" x 10' Filler	68.00 LB
F11012	12" x 10' Filler	65.00 LB
F11010	10" x 10' Filler	58.00 LB
F11008	8" x 10' Filler	53.00 LB
F11006	6" x 10' Filler	49.00 LB
F11005	5" x 10' Filler	46.00 LB
F11004	4" x 10' Filler	42.00 LB
F11002	2" x 10' Filler	28.80 LB
F11003	1 1/2" x 10' Filler	26.54 LB
F11001	1" x 10' Filler	24.26 LB
F11025	6" x 10' Inside Corner	78.05 LB
F60365	4" x 10' Inside Corner	58.45 LB
F11027	10' Outside Corner	30.70 LB
F11026	10' Filler Angle	14.40 LB
F30020	10' Inside Bay Corner	50.29 LB
F30010	10' Outside Bay Corner	91.72 LB
F30100	30" x 10' Adj. Column Form	143.00 LB

**9 FT EQUIPMENT\***

Product Code	Description	Weight
F10924	24" x 9' Panel	89.00 LB
F10922	22" x 9' Filler	81.67 LB
F10920	20" x 9' Filler	76.23 LB
F10918	18" x 9' Filler	72.17 LB
F10916	16" x 9' Filler	66.00 LB
F10914	14" x 9' Filler	61.29 LB
F10912	12" x 9' Filler	56.33 LB
F10910	10" x 9' Filler	51.64 LB
F10908	8" x 9' Filler	46.00 LB
F10906	6" x 9' Filler	43.00 LB
F10905	5" x 9' Filler	42.00 LB
F10904	4" x 9' Filler	39.00 LB
F10902	2" x 9' Filler	25.94 LB
F10903	1-1/2" x 9' Filler	23.89 LB
F10901	1" x 9' Filler	21.84 LB
F10925	6" x 9' Inside Corner	68.50 LB
F60364	4" x 9' Inside Corner	52.61 LB
F10927	9' Outside Corner	27.63 LB
F10926	9' Filler Angle	12.96 LB
F10928	9' Pilaster Form	97.00 LB
F30099	30" x 9' Adj Column Form	134.00 LB
F30019	9' Inside Bay Corner	39.00 LB
F30009	9' Outside Bay Corner	82.61 LB
F30083	9' Inside Hinge Corner	75.00 LB
F30263	9' Outside Hinge Corner	24.00 LB

**8' EQUIPMENT**

Product Code	Description	Weight
F10824	24" x 8' Panel	78.65 LB
F10822	22" x 8' Filler	73.71 LB
F10820	20" x 8' Filler	70.08 LB
F10818	18" x 8' Filler	65.71 LB
F10816	16" x 8' Filler	60.45 LB
F10814	14" x 8' Filler	56.18 LB
F10812	12" x 8' Filler	51.94 LB
F10810	10" x 8' Filler	61.76 LB
F10808	8" x 8' Filler	40.96 LB
F10806	6" x 8' Filler	41.44 LB
F10805	5" x 8' Filler	37.00 LB
F10804	4" x 8' Filler	34.45 LB
F10802	2" x 8' Filler	23.00 LB
F10803	1-1/2" x 8' Filler	21.52 LB
F10801	1" x 8' Filler	18.86 LB
F10825	6" x 8' Inside Corner	63.58 LB
F60363	4" x 8' Inside Corner	44.00 LB
F10827	8' Outside Corner	23.75 LB
F10826	8' Filler Angle	11.48 LB
F10828	8' Pilaster Form	80.27 LB
F30098	30" x 8' Adj. Column Form	116.17 LB
F30078	8' Inside Hinge Corner	60.67 LB
F30228	8' Outside Hinge Corner	20.00 LB
F30018	8' Inside Bay Corner	7.86 LB
F30008	8' Outside Bay Corner	73.03 LB
F10341	8' Double Hinge Filler	83.00 LB
F10061	8' Keyway Form	6.00 LB
F30048	12" x 8' Culvert Form	126.00 LB
F30038	9" x 8' Culvert Form	68.00 LB
F30028	6" x 8' Culvert Form	98.00 LB

**7 FT EQUIPMENT\***

Product Code	Description	Weight
F10724	24" x 7'-0" Steel-Ply Panel	71.00 LB

\*For purchase only



# CONCRETE FORM SYSTEMS

## Steel-Ply Forming System, continued

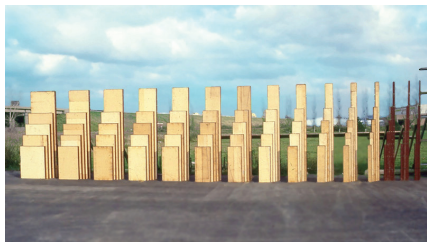

### 6 FT EQUIPMENT

Product Code	Description	Weight
F10624	24" x 6' Panel	60.00 LB
F10622	22" x 6' Filler	56.65 LB
F10620	20" x 6' Filler	53.38 LB
F10618	18" x 6' Filler	49.80 LB
F10616	16" x 6' Filler	46.27 LB
F10614	14" x 6' Filler	43.50 LB
F10612	12" x 6' Filler	40.31 LB
F10610	10" x 6' Filler	35.67 LB
F10608	8" x 6' Filler	33.77 LB
F10606	6" x 6' Filler	29.14 LB
F10605	5" x 6' Filler	26.94 LB
F10604	4" x 6' Filler	26.00 LB
F10602	2" x 6' Filler	17.74 LB
F10603	1-1/2" x 6' Filler	16.57 LB
F10601	1" x 6' Filler	14.58 LB
F10625	6" x 6' Inside Corner	48.50 LB
F60361	4" x 6' Inside Corner	33.25 LB
F10627	6' Outside Corner	17.91 LB
F10626	6' Filler Angle	7.39 LB
F10628	6' Pilaster Form	59.63 LB
F30102	30" x 6' Adj. Column Form	88.20 LB
F30076	6' Inside Hinge Corner	49.00 LB
F30226	6' Outside Hinge Corner	18.00 LB
F30016	6' Inside Bay Corner	30.30 LB
F30006	6' Outside Bay Corner	54.20 LB
F10342	6' Double Hinge Filler	59.20 LB
F10062	6' Keyway Form	12.00 LB
F30046	12" x 6' Culvert Form	90.00 LB
F30036	9" x 6' Culvert Form	62.50 LB
F30026	6" x 6' Culvert Form	62.00 LB

### 5 FT EQUIPMENT

Product Code	Description	Weight
F10524	24" x 5' Panel	51.56 LB
F10522	22" x 5' Filler	47.57 LB
F10520	20" x 5' Filler	45.13 LB
F10518	18" x 5' Filler	41.78 LB
F10516	16" x 5' Filler	39.10 LB
F10514	14" x 5' Filler	36.23 LB
F10512	12" x 5' Filler	32.95 LB
F10510	10" x 5' Filler	30.30 LB
F10508	8" x 5' Filler	26.80 LB
F10506	6" x 5' Filler	25.60 LB
F10505	5" x 5' Filler	23.00 LB
F10504	4" x 5' Filler	21.30 LB
F10502	2" x 5' Filler	16.00 LB
F10503	1-1/2" x 5' Filler	10.36 LB
F10501	1" x 5' Filler	12.21 LB
F10525	6" x 5' Inside Corner	40.48 LB
F60360	4" x 5' Inside Corner	28.65 LB
F10527	5' Outside Corner	14.58 LB
F10526	5' Filler Angle	7.09 LB
F10528	5' Pilaster Form	54.82 LB
F30081	30" x 5' Adj. Column Form	77.20 LB
F30075	5' Inside Hinge Corner	41.00 LB
F30225	5' Outside Hinge Corner	13.86 LB
F30015	5' Inside Bay Corner	24.50 LB
F30005	5' Outside Bay Corner	48.20 LB
F10343	5' Double Hinge Filler	48.00 LB
F10063	5' Keyway Form	10.00 LB
F30045	12" x 5' Culvert Form	57.25 LB
F30035	9" x 5' Culvert Form	56.25 LB
F30025	6" x 5' Culvert Form	38.89 LB

### 4 FT EQUIPMENT

Product Code	Description	Weight
F10424	24" x 4' Panel	41.68 LB
F10422	22" x 4' Filler	39.46 LB
F10420	20" x 4' Filler	37.20 LB
F10418	18" x 4' Filler	33.98 LB
F10416	16" x 4' Filler	32.20 LB
F10414	14" x 4' Filler	29.67 LB
F10412	12" x 4' Filler	27.38 LB
F10410	10" x 4' Filler	24.47 LB
F10408	8" x 4' Filler	22.89 LB
F10406	6" x 4' Filler	20.53 LB
F10405	5" x 4' Filler	18.00 LB
F10404	4" x 4' Filler	17.53 LB
F10402	2" x 4' Filler	10.32 LB
F10403	1-1/2" x 4' Filler	10.99 LB
F10401	1" x 4' Filler	9.87 LB
F10425	6" x 4' Inside Corner	33.08 LB
F60359	4" x 4' Inside Corner	28.00 LB
F10427	4' Outside Corner	11.84 LB
F10426	4' Filler Angle	5.70 LB
F10428	4' Pilaster Form	44.10 LB
F30094	30" x 4' Adj. Column Form	59.90 LB
F30074	4' Inside Hinge Corner	29.90 LB
F30224	4' Outside Hinge Corner	9.92 LB
F30014	4' Inside Bay Corner	19.60 LB
F30004	4' Outside Bay Corner	38.39 LB
F10344	4' Double Hinge Filler	38.60 LB
F10064	4' Keyway Form	8.00 LB
F30044 1	2" x 4' Culvert Form	44.00 LB
F30034	9" x 4' Culvert Form	56.50 LB
F30024	6" x 4' Culvert Form	30.00 LB

**3 FT EQUIPMENT**

Product Code	Description	Weight
F10324	24" x 3' Panel	32.70 LB
F10322	22" x 3' Filler	30.48 LB
F10320	20" x 3' Filler	28.87 LB
F10318	18" x 3' Filler	27.10 LB
F10316	16" x 3' Filler	25.04 LB
F10314	14" x 3' Filler	23.00 LB
F10312	12" x 3' Filler	21.15 LB
F10310	10" x 3' Filler	18.20 LB
F10308	8" x 3' Filler	17.14 LB
F10306	6" x 3' Filler	15.56 LB
F10305	5" x 3' Filler	14.00 LB
F10304	4" x 3' Filler	13.00 LB
F10302	2" x 3' Filler	8.49 LB
F10303	1-1/2" x 3' Filler	8.55 LB
F10301	1" x 3' Filler	6.46 LB
F10325	6" x 3' Inside Corner	25.20 LB
F60358	4" x 3' Inside Corner	18.17 LB
F10327	3' Outside Corner	10.96 LB
F10326	3' Filler Angle	4.23 LB
F10328	3' Pilaster Form	35.00 LB
F30111	30" x 3' Adj. Column Form	46.17 LB
F30073	3' Inside Hinge Corner	22.43 LB
F30223	3' Outside Hinge Corner	7.80 LB
F30013	3' Inside Bay Corner	16.00 LB
F30003	3' Outside Bay Corner	28.80 LB
F10345	3' Double Hinge Filler	29.20 LB
F10065	3' Keyway Form	6.00 LB
F30043	12" x 3' Culvert Form	35.00 LB
F30033	9" x 3' Culvert Form	38.00 LB
F30023	6" x 3' Culvert Form	31.00 LB

**2 FT EQUIPMENT\***

Product Code	Description	Weight
F10380	24" x 2' Panel	20.00 LB
F10222	22" x 2' Filler	19.50 LB
F10220	20" x 2' Filler	17.50 LB
F10218	18" x 2' Filler	16.50 LB
F10216	16" x 2' Filler	16.00 LB
F10214	14" x 2' Filler	14.00 LB
F10212	12" x 2' Filler	13.00 LB
F10210	10" x 2' Filler	12.00 LB
F10208	8" x 2' Filler	11.00 LB
F10206	6" x 2' Filler	9.50 LB
F10205	5" x 2' Filler	8.50 LB
F10204	4" x 2' Filler	7.00 LB
F10202	2" x 2' Filler	5.50 LB
F10203	1-1/2" x 2' Filler	5.00 LB
F10201	1" x 2' Filler	4.50 LB
F10225	6" x 2' Inside Corner	17.00 LB
F60354	4" x 2' Inside Corner	14.00 LB
F10227	2' Outside Corner	6.00 LB
F10226	2' Filler Angle	2.80 LB
F101051	30" x 2' Adj. Column Form	27.00 LB
F102027	2' Inside Hinge Corner	17.00 LB
F102028	2' Outside Hinge Corner	6.00 LB
F30012	2' Inside Bay Corner	10.31 LB
F30002	2' Outside Bay Corner	18.90 LB

**CONNECTING HARDWARE**

Product Code	Description	Weight
F60058	Wedge Bolts (PURCHASE ONLY)	0.12 LB
60058	Wedge Bolts (RENTAL ONLY)	0.12 LB
F60050	S-Wedge	0.16 LB
F60052	Long Bolt	0.16 LB
F60049	Short Bolt	0.11 LB
F40408	Adj. Long Bolt	0.19 LB
F60087	Base Tie Bolt	0.03 LB
F60057	Gang Form Bolt	0.31 LB
F40121	Gang Form Adapter Sleeve	0.49 LB
F36162	Quick Column Hardware	0.78 LB
F10853	S/P Column Hinge	3.68 LB
F42121	Scaffold Bracket Bolt	0.01 LB

**COLUMN FORMS\***

Product Code	Description	Weight
F19324	24" x 3' Steel-Ply 2000 lb. Panel	34.50 LB
F19424	24" x 4' Steel-Ply 2000 lb. Panel	46.00 LB
F19524	24" x 5' Steel-Ply 2000 lb. Panel	60.30 LB
F19624	24" x 6' Steel-Ply 2000 lb. Panel	74.50 LB
F19824	24" x 8' Steel-Ply 2000 lb. Panel	97.30 LB
F19880	24" x 9' Steel-Ply 2000 lb. Panel	125.70 LB

\*For purchase only

# CONCRETE FORM SYSTEMS

## Steel-Ply Forming System, continued



Product Code	Description	Weight
F60779	24" x 10' Steel-Ply 2000 lb. Panel	125.70 LB

### WALER/STRONGBACK HARDWARE

Product Code	Description	Weight
F60321	HD One Piece Waler Clamp	1.92 LB
F60318	One Piece Waler Clamp	1.89 LB
F60056	Z Tie Holder	0.76 LB
F60062	Waler Tie 2x4	0.12 LB
F60063	Waler Tie 2x6	0.10 LB
F60059	Strongback Tie 2x4 - 2x4	0.17 LB
F60060	Strongback Tie 2x6 - 2x4	0.20 LB
F60061	Strongback Tie 2x6 - 2x6	0.20 LB
F40038	J-Strongback Hook 2x6 - 2x4	1.54 LB
F40039	J-Strongback Hook 2x6 - 2x6	1.57 LB
F40040	J-Strongback Hook 2x4 - 2x4	1.38 LB
F60032	8" Gang Waler Rod	0.33 LB
F60033	14" Gang Waler Rod	0.61 LB
F60034	18" Gang Waler Rod	0.79 LB
45600	1/2" Coil Nut (Former PC 31616 1/2" Contour Nut)	0.06 LB
F42116	Gang Waler Plate	0.58 LB
F33747	Channel Aligner Bracket	1.50 LB
F60136	L Washer	0.59 LB
F142651	4" J-Strongback Rod	1.70 LB
F33151	Panel Waler Connector	2.50 LB
F33779	Clip Angle for Panel Waler Connector	0.60 LB
F60091	Pipe Aligner Hook	0.30 LB
F60137	Strongback U-Bolt	0.20 LB

### SCAFFOLD AND BRACING HARDWARE

Product Code	Description	Weight
F40300	Scaffold Bracket	14.54 LB
F40103	Turnbuckle - Straight Plate	7.67 LB
F40120	Turnbuckle - Bent Plate	6.76 LB

Product Code	Description	Weight
F41400	Attachment Plate	1.00 LB
F10852	Corewall Turnbuckle	10.00 LB
F40436	27" Ratchet Turnbuckle	10.31 LB
F33697	Pipe Form Aligner	110.80 LB
49610	A27M Low Cost Turnbuckle Straight Plate (Former F40108)	8.09 LB
49210	A27 Low Cost Turnbuckle - Bent Plate (Former F40104)	8.09 LB
F40119	Turnbuckle - Bent Plate Combo	8.12 LB

### HARDWARE

Product Code	Description	Weight
F30069	45° Bay Corner Bracket	0.75 LB
F60117	Column Lifting Corner	13.51 LB
F60378	Double Duty Lift Bracket	7.68 LB
F60031	Safety Eye	0.70 LB
F40442	Multi-Shear Wall Bracket	14.25 LB
F40447	Guide Plate	1.20 LB
F48000	Column Filler Angle	4.06 LB
F41600	Form Extension Bracket	1.81 LB
F41800	Brick Ledge Bracket	0.54 LB
F40600	Cantilever Bracket	12.46 LB
F40106	Cantilever Clip	2.00 LB
F36136	1/2" x 1" Fast Pin	0.10 LB
F10060	S/P Bulkhead Bar	7.00 LB
F60122	Batter Tie Down Bracket	2.50 LB
F60118	Footing Corner Bracket	4.40 LB
F60190	Stake Plate	0.47 LB
F40417	Haunch Support Bracket	23.20 LB
F60402	Pilaster Brace	3.00 LB
F60025	21' Pipe Waler	63.00 LB
F60026	21' Curved Pipe Waler	57.10 LB

### ACCESSORIES

Product Code	Description	Weight
F60184	8" Beam Pocket	5.00 LB

Product Code	Description	Weight
F65002	Symons Red Paint	11.65 LB
F43127	Symons Form Fix w/ hardener	15.75 LB
F65009	Plywood Edge Seal (grey) 5 gal	50.00 LB
F60141	1/4" x 1" Flat Head Alum. Rivet	0.01 LB
F60119	1/4" x 1" Drive Rivet	0.01 LB
F60139	3/16" x 1" Cad. Plated Bolt and Nut Set	0.01 LB
F40226	13/16" Plastic Form Plug	0.01 LB
F40228	1-1/16" Plastic Form Plug	0.00 LB
F32501	1-5/16" Plastic Form Plug	0.00 LB
F40231	1-9/16" Plastic Form Plug	0.01 LB
F40110	Keeper Bolt	0.20 LB
F40338	Special - 20 Reusable Square Nut	0.10 LB
F50018	1" Hinged Cone (for Panel Tie)	0.01 LB
F50014	Neoprene Washer (for Panel Tie)	0.00 LB
F42150	3/4" x 8'-0" Rubber Chamfer Strip w/ tail	1.30 LB
F36406	5/16" -18x1" Sq. Neck Bolt (for Keyway Form)	0.09 LB
F36405	5/16" Standard Washer (for Keyway Form)	0.01 LB
F40322	5/16" -18 Hex Nut (for Keyway Form)	0.30 LB
64100	1-3/4" Ply Hole Cover (Former F60351)	0.02 LB
64120	2-1/4" Ply Hole Cover (Former F60352)	0.03 LB
64125	2-3/4" Ply Hole Cover (Former F60350)	0.04 LB



## Adaptable Steel-Ply Wins the Jobs

Williams Brothers Construction, based in Peoria, Illinois, was awarded the construction contract for expanding a wastewater treatment plant in Coal City, Illinois.

The expansion included the construction of several concrete structures and foundations, and the contractor was interested in renting one forming system to handle the entire project.

Although gangforming systems with larger panel sizes offered some productivity advantages for certain areas in the design, the contractor was concerned that conditions would impede the use of a large crane for handling heavy gangs in the potentially wet, low-lying areas at the job site.

After considering their options, they felt that only Steel-Ply provided the combination of design adaptability, high reuse and light weight that they were looking for in this project.

Once they selected Steel-Ply for this job, they realized that the system qualities they admired the most meant that Steel-Ply would also be their preferred forming system for many of their other projects. So, instead of renting the forms, they decided to purchase most of the Steel-Ply utilized on the wastewater treatment plant expansion.

The contractor appreciated the ability to obtain quality ties and forms from the same manufacturer — Symons by Dayton Superior. This maximized convenience and assured a known safety factor, both important considerations for the contractor.

Williams Brothers reports that Steel-Ply impressed them with its versatility and the ability to meet the requirements for their many concrete construction projects.



The Steel-Ply forming system was used for foundations and walls throughout this large expansion project.



Steel-Ply forms were used in a handset application where muddy conditions did not allow them to place a large crane.

# CONCRETE FORM SYSTEMS

## Sym-Ply® Forming System

Designed to the demanding requirements of today's construction projects.

### Simply Faster

- Sym-Ply's speed of assembly and versatility allows for more productivity on a job site.
- The lightweight design allows for hand-ganging by two men without the use of a crane

### Simply Easier

- Fast clamp connections with a focused fleet package in imperial dimensions.
- Accessories with built in attachments mean no loose parts.

### Simply Stronger

- 80ksi steel manufactured to Symons' standards results in a tough, durable product.
- A guaranteed 1,500psf pour pressure.

### Key Features:

- The only clamp system in the market with a direct attachment to Steel-Ply
- 1,500psf pour pressure rating
- Panels weigh 8 pounds per square foot
- 5/8" 100/30 plywood face
- 1-7/16" diameter tie hole accommodates up to a 50kip taper ties and she-bolts
- Panels can accommodate 10 degrees of batter without special tie attachments.
- Profiled side rails allow pry bar access for adjusting gangs to the chalk line.

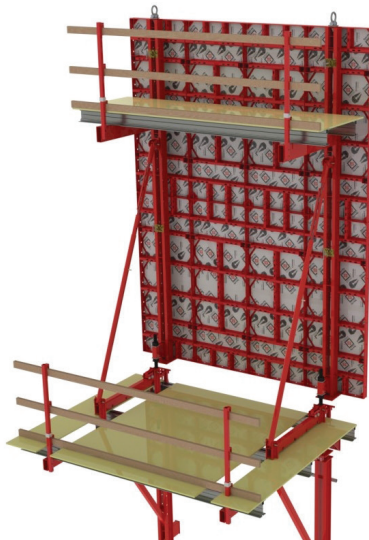

The Symons Sym-Ply concrete forming system has been designed and manufactured to meet the demanding requirements of today's construction requirements. With its direct attachment to and 100% compatibility with Steel-Ply, Sym-Ply is the most versatile forming system on the market. This system can be used on nearly any vertical concrete on Mid-Rise or High-Rise buildings including foundations, shear walls, elevator and stair cores and columns.

### PANELS AND FILLERS

Product Code	Description	Weight
F56000	9' x 8' Panel	775.00 LB
F56001	36" x 8' Panel	166.00 LB
F56002	30" x 8' Panel	187.00 LB
F56003	24" x 8' Panel	128.00 LB
F56004	18" x 8' Panel	106.50 LB
F56005	12" x 8' Panel	80.00 LB
F56006	6" x 8' Filler	51.00 LB
F56007	2" x 8' Filler	33.00 LB
F56008	1" x 8' Filler	38.00 LB
F56009	Slip Plate 8'	52.97 LB
F56010	12" x 8' Stripping Filler	139.67 LB
F56011	36" x 6' Panel	140.00 LB
F56012	30" x 6' Panel	154.00 LB
F56013	24" x 6' Panel	110.00 LB
F56014	18" x 6' Panel	85.00 LB
F56015	12" x 6' Panel	69.00 LB
F56016	6" x 6' Filler	39.00 LB
F56017	2" x 6' Filler	25.00 LB
F56018	1" x 6' Filler	29.00 LB
F56019	Slip Plate 6'	64.00 LB
F56020	12" x 6' Stripping Filler	109.00 LB
F56021	36" x 4' Panel	94.00 LB
F56022	30" x 4' Panel	104.00 LB
F56023	24" x 4' Panel	69.00 LB
F56024	18" x 4' Panel	60.64 LB
F56025	12" x 4' Panel	43.00 LB
F56026	6" x 4' Filler	27.00 LB
F56027	2" x 4' Filler	17.00 LB
F56028	1" x 4' Filler	20.00 LB
F56029	Slip Plate 4'	39.40 LB
F56030	12" x 4' Stripping Filler	75.56 LB
F56041	36" x 2' Panel	55.00 LB
F56042	30" x 2' Panel	57.00 LB
F56043	24" x 2' Panel	40.00 LB
F56044	18" x 2' Panel	36.55 LB
F56045	12" x 2' Panel	28.00 LB
F56342	15cm x 120cm Panel	22.00 LB
F56343	15cm x 180cm Panel	32.50 LB
F56344	15cm x 240cm Panel	42.50 LB



### CORNERS

Product Code	Description	Weight
F56032	12" x 12" x 6' Inside Corner	129.00 LB
F56033	12" x 12" x 4' Inside Corner	93.00 LB
F56035	Outside Corner 8'	34.00 LB
F56036	Outside Corner 6'	28.00 LB
F56037	Outside Corner 4'	19.00 LB
F56091	12" x 12" x 8' Stripping Corner	233.30 LB
F56090	12" x 12" x 6' Stripping Corner	171.67 LB
F56089	12" x 12" x 4' Stripping Corner	116.33 LB



### HARDWARE AND ACCESSORIES

Product Code	Description	Weight
F56351	Sym-Clamp - Vertical	4.38 LB
F56352	Adj. Sym-Clamp - Vertical	5.00 LB
F56354	15mm 7" Circular Tie Plate	5.21 LB
F56062	T-Head Sym-Bolt Assembly	4.07 LB
F56097	Bulkhead Sym-Hook Long	3.65 LB
F56064	Short Sym-Waler	43.34 LB
F56098	10' Sym-Waler	85.70 LB
F56099	13' Sym-Waler	112.30 LB
F56065	Lift Bracket	12.00 LB
F56066	Aligner Bracket	4.75 LB
F56067	Walkway Bracket	14.16 LB
F56068	Fall Forward Bracket	5.36 LB
F56042	Guardrail Post	9.17 LB
F56069	Top Tie Bracket	6.14 LB
F56395	Sym-Ply Tie-Down Bracket	2.33 LB
F56092	Sym-Ply Tie-Off Bracket	1.83 LB
F56096	T-Head Sym-Bolt Assy. Long	4.20 LB
F56093	Sym-Ply Turn Buckle Bracket	3.25 LB
F56913	Sym-Ply J-Hook	2.00 LB
F56914	Sym-Ply Stacking Clamp	24.77 LB

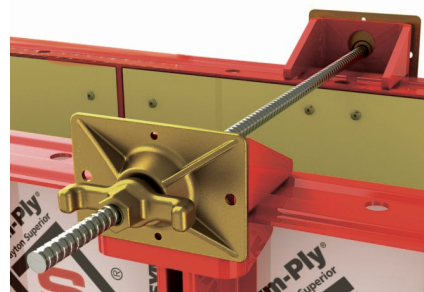

# CONCRETE FORM SYSTEMS

## Sym-Ply Forming System, continued



Lewis Construction, Sand Mine, Chippewa Falls, Wisconsin

*"The forms went together easily, and the clamp connections made for fast gang assembly," said Todd Masephol, Concrete Superintendent.*

### OTHER HARDWARE AND ACCESSORIES

Product Code	Description	Weight
125090	15mm 41" Taper(16) Tie 3/4-1" (Purchase Only) Purchase Only (Rental Product Code Sw667023)	4.8 LB
F5W667022	D9a- 5/8" x 49" Taper Tie 1" To 5/8"X24" Taper USA	6.5 LB
123511	15mm 57" Taper(32) Tie 3/4-1"	6.61 LB
123953	15mm 65" Taper(40) Tie 3/4-1"	6.89 LB
145555	20mm X 37 Taper Tie (19.5" Taper From 1-1/4" To 1")	8.15 LB
145556	20mm X 47 Taper Tie (29.5" Taper From 1-1/4" To 1")	11 LB
145557	20mm X 57 Taper Tie (39.5" Taper From 1-1/4" To 1")	13.85 LB
145558	20mm X 67 Taper Tie (49.5" Taper From 1-1/4" To 1")	15.8 LB
123504	18 20mm She Bolt	3.29 LB
123506	24 20mm She Bolt	3.96 LB
F56354	15mm - 7" Circular Tie Plate	5.21 LB
122021	15mm Swivel Wing Nut (4 X 4" Tie Plate/ Nut)	2.78 LB
127205	15mm Cast Nut Washer	1.64 LB
145554	20mm B12a Swivel Wing Nut (7" Dia. Round Plate - 65k Ultimate Load)	5.94 LB
F56516	Tie Hole Plug (9' X 8' Panel)	0.01 LB
F56517	Tie Hole Sleeve Insert (9' X 8' Panel)	0.02 LB



### PURCHASE ONLY PRODUCTS

Product Code	Description	Weight
F56070	Plastic Sleeve Plate (Bags of 300 each)	0.05 LB
F56071	Plastic Sym-Plug (Bags of 900 each)	0.01 LB
F56271	1/4" x 3/4" Sym-Ply Drive Rivet*	0.01 LB
F56272	1/4" x 1" Sym-Ply Drive Rivet*	0.01 LB
F56353	Sym-Ply Handling Bar	1.43 LB
F96476	4' x 10' x 5/8" HDO Logo Classic Plywood	79.00 LB
F96475	4' x 8' x 5/8" Logo Plywood	63.00 LB
F40226	Plastic Form Plug (Used for Sym-Ply Inside Corners)	0.01 LB
F56171	Sym-Ply Quick Hook Handle - Small Diagonal (incl. 2 F56920 Nuts & 2 F56919 Washers)	1.50 LB
F56172	Sym-Ply Quick Hook Handle - Large Diagonal (incl. 2 F56920 Nuts & 2 F56919 Washers)	1.50 LB
F56173	Sym-Ply Quick Hook Handle - Square (incl. 2 F56920 Nuts & 2 F56919 Washers)	1.25 LB
F56919	Sym-Ply Quick Hook Washer	0.05 LB
F56920	Sym-Ply Quick Hook Lock Nut	0.10 LB
F56084	Sym-Ply 15mm Sleeve Insert (Bags of 250 ea., Box of 500 ea.)	0.02 LB
F56085	Sym-Ply 15mm Insert Plug (Bags of 500 ea., Box of 1,000 ea.)	0.01 LB

\* Sym-Ply Drive Rivets, both 3/4" and 1", come in bags of 500 each



## Sym-Ply Provides the Solution

Lewis Construction, based in Schofield, Wisconsin, was the contractor handling construction of a busy, state-of-the-art sand mine that had several weekly trains transporting the material all around the country. Owner Steve Lewis, who had often utilized Symons by Dayton Superior product solutions over the years, approached the company again to provide forming solutions for the project.

### Challenge

Plans for the new sand mine posed a challenge of variations in wall height ranging from 7'-6" to 18'-0" with batter also changing with each different wall height. Lewis Construction already owned Symons by Dayton Superior Steel-Ply forms, but needed additional forming options that would allow an easy transition from one wall height to the next.

### Solution

Symons by Dayton Superior's Sym-Ply forming provided a perfect solution. Sym-Ply's ability to easily and quickly connect to Steel-Ply allowed for no delays in the placement of forms. The contractor was also able to avoid purchasing fractional wall ties by using taper ties to easily adjust to the different size batters. More than 3,700 square feet of Sym-Ply was used to form 100 lineal feet of tapered and battered wall.

"The forms went together easily and the clamp connections made for fast gang assembly," said Todd Masephol, Concrete Superintendent for Lewis Construction.

### Results

- Sym-Ply's ability to bolt directly to Steel-Ply saved the contractor time and money
- Contractor was able to save money by using taper ties rather than purchasing fractional ties
- Fast gang assembly saved the contractor time and money on site
- Symons by Dayton Superior served as a single-source provider for the contractors forming solutions.



Cycling gangs of forms through a number of pours allows contractors to reduce materials needed on the job site.

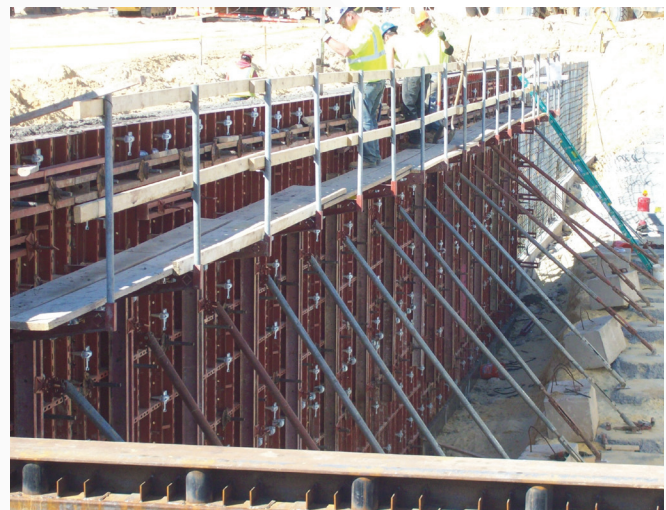

The Sym-Ply system includes a complete line of accessories, such as walkway brackets and braces.



Standard Taper Ties can be used even when Steel-Ply is included in a project, simplifying inventory.

# CONCRETE FORM SYSTEMS

## Tower-Max® Round Column Forms

Symons offers a wide selection of all-steel Tower-Max round column forms to meet your project's requirements. All steel construction results in a high-quality finish and a long-lasting form and a wide selection of diameters and heights help to meet project requirements. Custom and non-standard diameters and heights can be manufactured.

- Engineered for 3,000 lbs. concrete pour pressure up to 60" diameter
- Engineered for 2,000 lbs. concrete pour pressure for diameters 61"+



### TOWER-MAX COLUMN FORMS (COMPLETE COLUMN FORM ASSEMBLY, TWO HALF SECTIONS)

#### Tower-Max 96" Circular Columns

Product Code	Description	Weight ea.
F1609610	96"x10' Tower-MAX CCF	2709.6 LB
F1609608	96"x8' Tower-MAX CCF	2195.6 LB
F1609606	96"x6' Tower-MAX CCF	1677.7 LB
F1609604	96"x4' Tower-MAX CCF	1161.8 LB
F1609603	96"x3' Tower-MAX CCF	945.3 LB
F1609602	96"x2' Tower-MAX CCF	645.8 LB
F1609601	96"x1' Tower-MAX CCF	346.9 LB

#### Tower-Max 66" Circular Columns

Product Code	Description	Weight ea.
F1606610	66"x10' Tower-MAX CCF	1942.2 LB
F1606608	66"x8' Tower-MAX CCF	1573.5 LB
F1606606	66"x6' Tower-MAX CCF	1202.2 LB
F1606604	66"x4' Tower-MAX CCF	832.2 LB
F1606603	66"x3' Tower-MAX CCF	679.1 LB
F1606602	66"x2' Tower-MAX CCF	462.2 LB
F1606601	66"x1' Tower-MAX CCF	245.8 LB

#### Tower-Max 84" Circular Columns

Product Code	Description	Weight ea.
F1608410	84"x10' Tower-MAX CCF	2476.8 LB
F1608408	84"x8' Tower-MAX CCF	2006.4 LB
F1608406	84"x6' Tower-MAX CCF	1532.3 LB
F1608404	84"x4' Tower-MAX CCF	1060 LB
F1608403	84"x3' Tower-MAX CCF	861 LB
F1608402	84"x2' Tower-MAX CCF	587.7 LB
F1608401	84"x1' Tower-MAX CCF	315 LB

#### Tower-Max 60" Circular Columns

Product Code	Description	Weight ea.
F1606010	60"x10' Tower-MAX CCF	1836.8 LB
F1606008	60"x8' Tower-MAX CCF	1487.6 LB
F1606006	60"x6' Tower-MAX CCF	1134.4 LB
F1606004	60"x4' Tower-MAX CCF	785.2 LB
F1606003	60"x3' Tower-MAX CCF	640.8 LB
F1606002	60"x2' Tower-MAX CCF	434.7 LB
F1606001	60"x1' Tower-MAX CCF	229.2 LB

#### Tower-Max 72" Circular Columns

Product Code	Description	Weight ea.
F1607210	72"x10' Tower-MAX CCF	2061.5 LB
F1607208	72"x8' Tower-MAX CCF	1670.8 LB
F1607206	72"x6' Tower-MAX CCF	1277.4 LB
F1607204	72"x4' Tower-MAX CCF	885.4 LB
F1607203	72"x3' Tower-MAX CCF	723.2 LB
F1607202	72"x2' Tower-MAX CCF	493.3 LB
F1607201	72"x1' Tower-MAX CCF	263.7 LB

#### Tower-Max 54" Circular Columns

Product Code	Description	Weight ea.
F1605410	54"x10' Tower-MAX CCF	1576.9 LB
F1605408	54"x8' Tower-MAX CCF	1278.2 LB
F1605406	54"x6' Tower-MAX CCF	977.4 LB
F1605404	54"x4' Tower-MAX CCF	677.6 LB
F1605403	54"x3' Tower-MAX CCF	550.8 LB
F1605402	54"x2' Tower-MAX CCF	377.8 LB
F1605401	54"x1' Tower-MAX CCF	205.3 LB

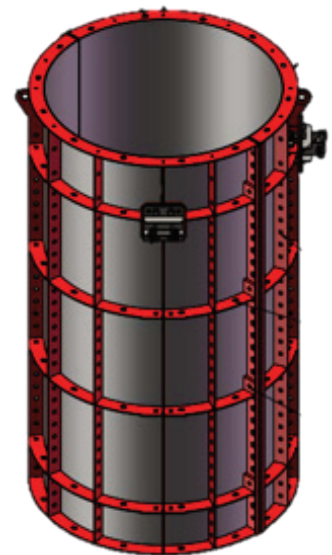

**Tower-Max 48" Circular Columns**

Product Code	Description	Weight ea.
F1604810	48"x10' Tower-MAX CCF	1414.7 LB
F1604808	48"x8' Tower-MAX CCF	1146.8 LB
F1604806	48"x6' Tower-MAX CCF	877 LB
F1604804	48"x4' Tower-MAX CCF	608.1 LB
F1604803	48"x3' Tower-MAX CCF	495 LB
F1604802	48"x2' Tower-MAX CCF	339.3 LB
F1604801	48"x1' Tower-MAX CCF	184 LB

**Tower-Max 42" Circular Columns**

Product Code	Description	Weight ea.
F1604210	42"x10' Tower-MAX CCF	1297.1 LB
F1604208	42"x8' Tower-MAX CCF	1051.1 LB
F1604206	42"x6' Tower-MAX CCF	803.2 LB
F1604204	42"x4' Tower-MAX CCF	556.3 LB
F1604203	42"x3' Tower-MAX CCF	452.1 LB
F1604202	42"x2' Tower-MAX CCF	309.3 LB
F1604201	42"x1' Tower-MAX CCF	167.1 LB

**Tower-Max 36" Circular Columns**

Product Code	Description	Weight ea.
F1603610	36"x10' Tower-MAX CCF	1039.4 LB
F1603608	36"x8' Tower-MAX CCF	843 LB
F1603606	36"x6' Tower-MAX CCF	645.4 LB
F1603604	36"x4' Tower-MAX CCF	448.4 LB
F1603603	36"x3' Tower-MAX CCF	367.4 LB
F1603602	36"x2' Tower-MAX CCF	251.4 LB
F1603601	36"x1' Tower-MAX CCF	135.9 LB

**Tower-Max 30" Circular Columns**

Product Code	Description	Weight ea.
F1603010	30"x10' Tower-MAX CCF	925.1 LB
F1603008	30"x8' Tower-MAX CCF	750 LB
F1603006	30"x6' Tower-MAX CCF	573.8 LB
F1603004	30"x4' Tower-MAX CCF	398.2 LB
F1603003	30"x3' Tower-MAX CCF	325.9 LB
F1603002	30"x2' Tower-MAX CCF	222.6 LB
F1603001	30"x1' Tower-MAX CCF	119.6 LB

**Tower-Max 24" Circular Columns**

Product Code	Description	Weight ea.
F1602410	24"x10' Tower-MAX CCF	810.1 LB
F1602408	24"x8' Tower-MAX CCF	656.5 LB
F1602406	24"x6' Tower-MAX CCF	501.9 LB
F1602404	24"x4' Tower-MAX CCF	347.7 LB
F1602403	24"x3' Tower-MAX CCF	284.3 LB
F1602402	24"x2' Tower-MAX CCF	193.2 LB
F1602401	24"x1' Tower-MAX CCF	102.6 LB

**Tower-Max 20" Circular Columns**

Product Code	Description	Weight ea.
F1602010	20"x10' Tower-MAX CCF	685.8 LB
F1602008	20"x8' Tower-MAX CCF	555.8 LB
F1602006	20"x6' Tower-MAX CCF	425.1 LB
F1602004	20"x4' Tower-MAX CCF	294.8 LB
F1602003	20"x3' Tower-MAX CCF	242.1 LB
F1602002	20"x2' Tower-MAX CCF	164.5 LB
F1602001	20"x1' Tower-MAX CCF	87.3 LB

**Tower-Max 18" Circular Columns**

Product Code	Description	Weight ea.
F1601810	18"x10' Tower-MAX CCF	646.6 LB
F1601808	18"x8' Tower-MAX CCF	523.9 LB
F1601806	18"x6' Tower-MAX CCF	400.5 LB
F1601804	18"x4' Tower-MAX CCF	277.5 LB
F1601803	18"x3' Tower-MAX CCF	227.8 LB
F1601802	18"x2' Tower-MAX CCF	154.5 LB
F1601801	18"x1' Tower-MAX CCF	81.7 LB

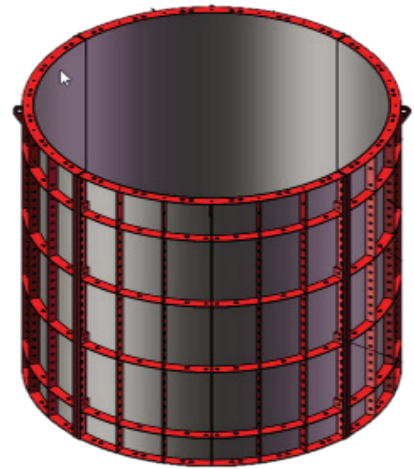

**Tower-Max Hardware/Accessories**

Product Code	Description	Weight
F32191	3/4" x 2" Speed Bolt	0.5 LB
F32193	3/4" DIA Speed Nut	0.25 LB
F32194	3/4" x 4" Speed Bolt	0.65 LB
F38061	Guardrail Post	15 LB
F38062	Alternate Walkway Bracket	23 LB
F35240	Walkway Connector	12 LB



Symons by Dayton Superior offers an extensive and versatile line of shoring and support systems for concrete construction. These product lines feature innovative approaches that focus on adaptability, strength and labor savings. These pre-engineered cast-in-place systems provide dependable temporary support that contractors and engineers know they can trust.

## SHORES AND SUPPORTS

Backbone™ .....	50
DeckFast™ .....	52
FrameFast™ .....	56
Garage Beam System .....	60
ShorFast™ .....	66
Space-Lift™ .....	70
Steel Form Support.....	72
Symons® Drop-Head System .....	74
Symons® Soldier Beam.....	76

## Backbone™ One-Sided Wall Form Support

Symons One-Sided Forming (OSF) frame is strong, flexible and allows concrete pressure up to 60 kN/m<sup>2</sup> (1,250psf). The distance between the Support Frames is determined by the height of the wall and the concrete pressure. The form is plumbed using jacks at the base.

Symons one-sided wall has Support Frames that transfer the forces through the anchors embedded in the concrete at the foot of the formwork and through the rear pressure jack on the bracket.

### Six Principle Components:

#### OSF Frame 325 (10'-8")

For one-sided forming up to a maximum height of 3.25m (10'-8")

#### OSF Waler for 325

The loads that arise during the use of the OSF Support Frame 325 are distributed via the waler into the anchor.

#### OSF Frame 500 (16'-5")

For one-sided forming up to a maximum height of 5m (16'-5"). A 1 x 2<sup>3</sup>/<sub>4</sub>" NC Grd 5 bolt, nut, and 1-1/8" flat washer is used to fasten a Frame 500 to Frames (4 of each per connection).

#### OSF Waler for 200/500

The loads that arise during the use of the Support Frame 500 and the Frame 200 are distributed via the waler into the anchor ties.

#### OSF Frame 200H x 300W (6'-6" x 9'-7")

Used with the Support Frame 500 for one-sided forming up to a maximum height of 6.6m (21'-7").

#### OSF Frame 200H x 413W (6'-6" x 13'-6")

Used together with the Frame 500 and the Frame 200H x 300W for one-sided forming up to a maximum height of 9m (29'-6").

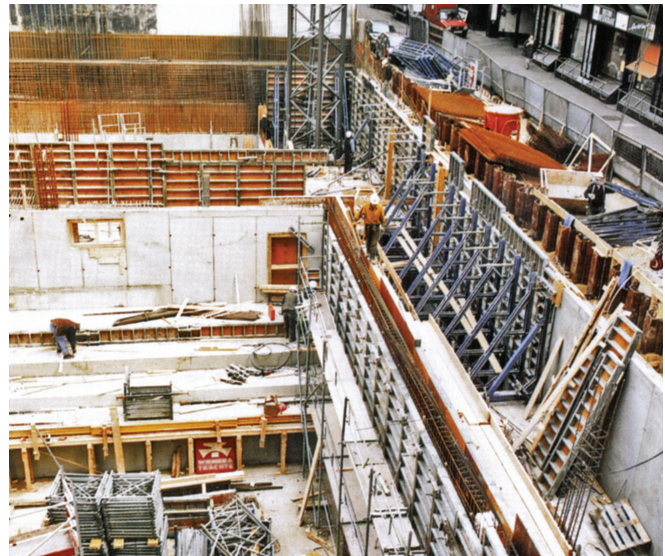

# SHORES AND SUPPORTS

With only six main components and pressure capacity up to 1,250 psf, Backbone is an efficient and cost effective method for supporting one-sided walls to nearly 30' in height. This versatile system has multiple stacking and anchoring options and can be used with virtually any forming system. Try Backbone for the deep foundation walls at the start of your mid-rise or high-rise building.

## SUPPORT FRAMES

Product Code	Description	Weight
FSW456016	Backbone Frame 325 Support with Jacks	379.63 LB
F61874	Backbone Support Frame 500 w/o Jack	600.09 LB
F61877	Backbone Front Jack	1912 LB
F61880	Backbone Rear Jack	38.61 LB
FSW456001	Backbone Lower Support Frame 200H x 300W	629.80 LB
F61930	Backbone Base Frame 200H x 413W	732.84 LB

## HARDWARE

Product Code	Description	Weight
FSW456008	Backbone Frame Brace 1/2 Clamp	EA 2.00 LB
FSW456015	Backbone Tie Down Water 5"	33.07 LB
FSW456012	Backbone Tie Down Water 8"	48.86 LB
F61955	15mm Tie Back	1.00 LB
F722110	15mm x 4" x 6" Tie Plate/Nut	2.79 LB
F61956	3/4" Tie Hole Mounting Bolt	2.00 LB
F61957	3/4" Tie Hole Mounting Nut	0.20 LB
FSW456007	Backbone Form Panel Spacer	12.10 LB
F61958	Backbone Bearing U Plate	2.00 LB
F61953	Backbone 1" x 3" Bolt	0.00 LB
F51398	1" Washer	0.10 LB
FSW450074	1.69 x 1.69 Swivel Clamp	4.20 LB

## PIPES

Product Code	Description	Weight
F19760	1.90" O.D. Std. Pipe x 4'	10.90 LB
F19761	1.90" O.D. Std. Pipe x 6'	16.40 LB
F19758	1.90" O.D. Std. Pipe x 7'	19.00 LB
F19762	1.90" O.D. Std. Pipe x 8'	21.80 LB
F19759	1.90" O.D. Std. Pipe x 14'	38.10 LB

## 20MM ANCHORING HARDWARE

Product Code	Description	Weight
F61945	Backbone 20mm Wing Nut	1.30 LB
F61947	Backbone 20mm Batter Plate	4.20 LB
F61968	Backbone 20mm x 42" Tie Down Rod	3.70 LB
F61944	Backbone 20mm Cone Coupler	1.60 LB
F61969	Backbone 20mm Double Frame Anchor	6.70 LB
F61967	Backbone 20mm x 16" Anchor Rod	1.70 LB
F61950	Backbone 20mm Anchor Plate/Nut	6.10 LB

## 26.5MM ANCHORING HARDWARE

Product Code	Description	Weight
F61965	Backbone 26.5mm Wing Nut	2.00 LB
F61948	Backbone 26.5mm Batter Plate	3.90 LB
F61962	Backbone 26.5mm x 42" Tie Down Rod	7.30 LB
F61964	Backbone 26.5mm Cone Coupler	10.50 LB
F61963	Backbone 26.5mm Double Frame Anchor	21.80 LB
F61961	Backbone 26.5mm x 16" Anchor Rod	4.00 LB
F61949	Backbone 26.5mm Anchor Plate/Nut	6.30 LB

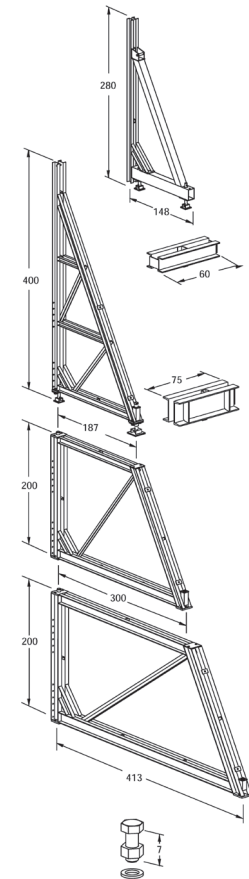

## DeckFast™ Shoring

As simple as erecting two components to support a ready-to-pour deck surface!

### Slab form productivity

DeckFast is the most efficient flat slab formwork system available. Just two basic deck and shore components means superior labor savings and forming productivity.

### Super-sized panels

The large DeckFast panel, 180cm x 180cm (nominal 6'x6'), accelerates set-up speed and overall labor savings of the system. The aluminum frame and high-capacity galvanized post shore with drop-pin, provides exceptional on-site productivity. Compared to the DeckFast system, conventional concrete deck shoring methods seem antiquated.

### Lower plywood costs

The DeckFast panels are supplied with installed HDO plywood. You receive the benefits of an excellent finish and nearly eliminate post pour defects. Typical plywood costs for conventional decking and related disposal costs are virtually eliminated.

### Fewer accessories

The system features just a few accessories to eliminate those costly in-fill areas around obstacles. Adjustable panels have built-in nailer strips to fill in odd dimensions.



# SHORES AND SUPPORTS

## 10.5MM HDO PLYWOOD (Cut-to-Size)

Product Code	Description	Weight
FSW969000	10.5mm x 180cm x 89cm HDO Plywood (2 pcs)	51.90 LB
FSW969003	10.5mm x 90cm x 75cm HDO Plywood	10.80 LB
FSW969009	10.5mm x 90cm x 90cm HDO Plywood	13.00 LB
FSW969006	10.5mm x 180cm x 45cm HDO Plywood	13.00 LB
FSW969001	90cm x 180cm HDO Plywood for Adj. Panel	10.60 LB
FSW969002	90cm x 90cm HDO Plywood for Corner	10.80 LB
FSW969004	10.5mm x 180cm x 75cm HDO Plywood	21.60 LB
FSW969005	10.5mm x 90cm x 45cm HDO Plywood	6.50 LB
FSW969007	10.5mm x 180cm x 60cm HDO Plywood	17.30 LB
FSW969008	10.5mm x 90cm x 60cm HDO Plywood	8.60 LB
FSW969010	10.5mm x 180cm x 90cm HDO Plywood	25.90 LB

## DECKFAST SYSTEM ACCESSORIES (Hardware and Accessories)

Product Code	Description	Weight
FSW450066	Swivel Clamp (1.69 x 1.9) - Frame to Pipe	4.20 LB
FSW450044	Swivel Clamp (1.9 x 3.0) - Pipe to Post	4.20 LB
FSW450049	DeckFast Erection Rod	9.50 LB
FSW450074	Swivel Clamp (1.69 x 1.69) - Tie Down to Frame	4.20 LB
FSW450043	Post Shore Bolt and Nut	0.10 LB

## 10.5MM PLYWOOD FOR DECKFAST

Product Code	Description	Weight
F95823	10.5mm x 4' x 8' HDO Plywood	41.40 LB

## CANTILEVER TIE DOWN (Hardware and Accessories)

Product Code	Description	Weight
FSW450029	Tie Down Frame	28.00 LB
FSW450030	Tie Down Hook	2.50 LB
FSW450032	Tie Down Hook and Handle	12.90 LB
FSW450028	Bracing Frame 180	39.40 LB

## DECKFAST FILLER HARDWARE (Panels and Support)

Product Code	Description	Weight
FSW450027	Transverse Beam	9.50 LB
FSW450024	Head Support Shoe	1.13 LB
FSW450025	Adjustment Beam 180	21.21 LB
FSW450026	Adjustment Beam 90	9.43 LB

## GUARDRAIL (Hardware and Accessories)

Product Code	Description	Weight
FSW450034	Guardrail Bracket	8.60 LB
FSW450037	Toeboard Clip	0.90 LB
FSW450038	Bearing Bolt (panel lift-off retainer)	0.20 LB
FSW556042	Guardrail Post	9.17 LB

## PANELS (Panels and Support)

Product Code	Description	Weight
FSW450010	90 x 90 cm Corner Panel	33.50 LB
FSW450011	180 x 90 cm Corner Plywood (reversible)	24.50 LB
FSW450012	180 x 90 cm Corner Frame (req.plywood)	38.60 LB
FSW450004	180 x 45 cm DeckFast Panel	29.80 LB
FSW450005	90 x 90 cm DeckFast Panel	26.30 LB
FSW450006	90 x 75 cm DeckFast Panel	22.90 LB
FSW450007	90 x 60 cm DeckFast Panel	19.80 LB
FSW450008	90 x 45 cm DeckFast Panel	15.70 LB
FSW450000	180 x 180 cm DeckFast Panel	100.80 LB
FSW450001	180 x 90 cm DeckFast Panel	47.20 LB
FSW450002	180 x 75 cm DeckFast Panel	41.50 LB
FSW450003	180 x 60 cm DeckFast Panel	36.20 LB
FSW450009	90 x 180 cm Adjustment Panel	54.50 LB

## POST SHORES AND SUPPORT

Product Code	Description	Weight
FSW450013	DeckFast Bearing	5.30 LB
FSW450017	350 Post Shore	46.50 LB
FSW450021	Post Shore Bearing Retainer	0.10 LB
FSW450023	Head Support Sleeve	4.40 LB
FSW450019	550 Post Shore Sleeve	0.83 LB
FSW450018	550 Post Shore	74.20 LB
FSW450014	Edge Support Bearing	3.84 LB
FSW450016	Post Shore Tripod	26.10 LB
FSW450022	Post Shore / Panel Retainer	0.20 LB
FSW450020	Post Shore T-Spring Bolt	0.45 LB





The small crew worked quickly, even at a forming height of twelve feet.



The system was erected at a rate of 160 square feet per manhour despite the crew not being familiar with it initially.

## DeckFast Deserves the Name

Ampac Development, a new concrete construction division of Bosscon Inc., was planning the construction of the elevated slabs at Beverly Place, a commercial, office and residential development in the heart of West Hollywood. The total floor plan is thirty five thousand square feet with two levels of parking below grade.

Ampac had only completed one concrete structure prior to tackling Beverly Place, so their knowledge of forming and shoring was minimal. They had used conventional frames on their previous project and originally were very reluctant to try another shoring system considering how unfamiliar they were to the industry as a whole.

In meetings with the Ampac owners, Symons demonstrated the key advantages of DeckFast. With only two components, a panel and post shore, DeckFast is easy to set up.

With delivery of the first shipment, Symons was on the site to educate the crew on the safe, efficient method to install DeckFast. Edward Kim, owner and President of Ampac, was on site with a small entourage to examine this foreign system and its promised productivity. With a five man crew, they were able to accomplish three thousand, two hundred square feet, at a height of twelve feet, in four hours that translated into one hundred and sixty square feet per manhour, leaving Mr. Kim and his team satisfied and smiling.

Ampac recognized the DeckFast advantage, adapted quickly to DeckFast and has gotten even faster with experience. Superintendent Michael Perry stated "DeckFast made my schedule," proving that DeckFast is the worlds most superior panelized shoring system.

# SHORES AND SUPPORTS



The composite-faced DeckFast panels produced an exceptional concrete finish.



The Microsoft Virtual Earth bird's eye view captured a view of the site preparation for Beverly Place.



The design of the stripping pin allows a simple hammer blow to relieve concrete pressure from the shore, making removal fast.



## FrameFast™ Shoring

Shoring and deck support systems for strength and application versatility.

### Aluminum beams and joists

The 7¼" beams and 6½" joists combine light weight, high strength, and cost-saving design features for joist and stringer applications. Aluminum Beams and Joists are available in standard lengths and incorporate wide flanges for stability.

### Shoring frames

For exceptional strength and durability, all Symons shoring frames are constructed of welded structural steel tubing. A typical load capacity is 12,000 lbs./leg (2.5:1 safety factor) up to three tiers high. Six FrameFast sizes are available in 3', 4', 5' and 6' heights and 2' and 4' widths.

### Post shores

Heavy duty post shores, in three models, provide adjustable shoring heights from 5'-7" to 16'-0". Each of these Post Shores has a load rating up to 10,000 lbs. (3:1 safety factor). With this higher load rating, Post Shores can often be spaced further apart, reducing equipment needs and providing labor-savings.

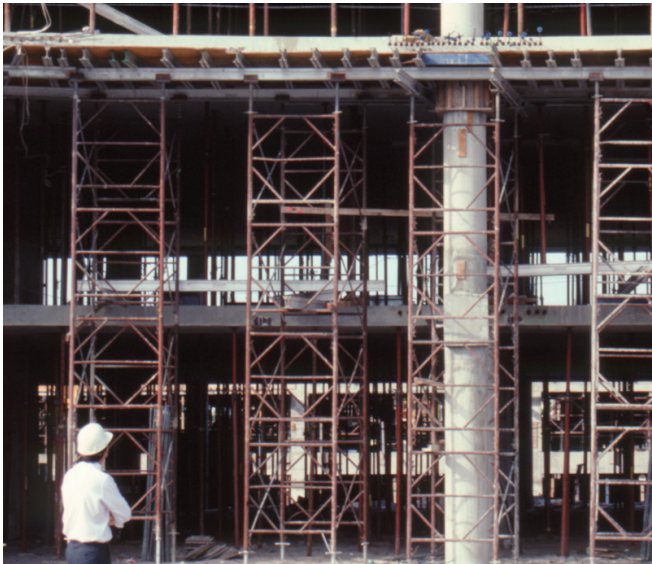

# SHORES AND SUPPORTS

The FrameFast shoring system is engineered for maximum strength, labor productivity and reuse capabilities.

The system includes Heavy Duty Shore Frames, Adjustable Post Shores and Aluminum Beams. These products are available in a wide range of sizes for virtually any deck forming application. A variety of special features and accessories make them fast and easy to use.

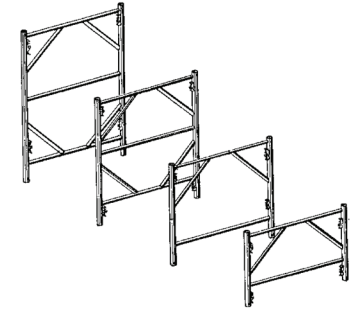

Nine lengths of crossbraces provide frame spacing from 3 to 15 feet. Crossbraces stabilize frames for tower rigidity.

## FF FRAMES - 24 KIP CAPACITY - (NO NEW RENTAL ADDS)

Product Code	Description	Weight
F48883	3'h x 2'w FF Frame - 24" Stud Center	30.50 LB
F48884	4'h x 2'w FF Frame - 24" Stud Center	40.00 LB
F48885	5'h x 2'w FF Frame - 48" Stud Center	50.50 LB
F48886	6'h x 2'w FF Frame - 48" Stud Center	60.00 LB
F49200	3'h x 4'w FF Frame - 24" Stud Center	36.00 LB
F49201	4'h x 4'w FF Frame - 24" Stud Center	43.00 LB
F49202	5'h x 4'w FF Frame - 48" Stud Center	62.00 LB
F49203	6'h x 4'w FF Frame - 48" Stud Center	70.00 LB

## SW FRAMES - 24 KIP CAPACITY

Product Code	Description	Weight
FSW894005	2'w x 4'h SW Frame - 36" Stud Center	35.00 LB
FSW894004	2'w x 5'h SW Frame - 48" Stud Center	45.00 LB
FSW894003	2'w x 6'h SW Frame - 48" Stud Center	55.00 LB
FSW894002	4'w x 4'h SW Frame - 36" Stud Center	46.00 LB
FSW894001	4'w x 5'h SW Frame - 48" Stud Center	54.00 LB
FSW894000	4'w x 6'h SW Frame - 48" Stud Center	67.00 LB

## SW LEDGER FRAMES - 24 KIP CAPACITY

Product Code	Description	Weight
FSW894007	4'w x 5'h SW Ledger Frame - 48" Stud Center	69.60 LB
FSW894006	4'w x 6'h SW Ledger Frame - 48" Stud Center	77.80 LB

## SINGLE-HOLE CROSS BRACES - 24" STUD CENTERS

Product Code	Description	Weight
F49255	CB 23 3' Frame Spacing	4.60 LB
F49035	CB 24 4' Frame Spacing	7.59 LB
F49038	CB 25 5' Frame Spacing	7.00 LB
F49068	CB 26 6' Frame Spacing	11.20 LB
F49031	CB 27 7' Frame Spacing	12.00 LB
F49027	CB 28 8' Frame Spacing	14.90 LB
F49042	CB 210 10' Frame Spacing	16.00 LB
F48875	CB 212 12' Frame Spacing	26.50 LB
F48876	CB 215 15' Frame Spacing	33.50 LB

## SINGLE-HOLE CROSS BRACES - 36" STUD CENTERS

Product Code	Description	Weight
FSW894076	CB 33 3' Frame Spacing	5.50 LB
FSW894077	CB 35 5' Frame Spacing	8.00 LB
FSW894078	CB 36 6' Frame Spacing	10.00 LB
FSW894079	CB 37 7' Frame Spacing	11.00 LB
FSW894080	CB 38 8' Frame Spacing	14.00 LB
F49095	CB 310 10' Frame Spacing	17.00 LB

## SINGLE-HOLE CROSS BRACES - 48" STUD CENTERS (NO NEW RENTAL ADDS)

Product Code	Description	Weight
F49256	CB 43 3' Frame Spacing	6.60 LB
F49037	CB 44 4' Frame Spacing	9.00 LB
F49040	CB 45 5' Frame Spacing	10.00 LB
F49041	CB 46 6' Frame Spacing	12.00 LB
F49033	CB 47 7' Frame Spacing	13.00 LB
F49094	CB 48 8' Frame Spacing	14.00 LB
F49096	CB 410 10' Frame Spacing	17.00 LB
F49297	CB 412 12' Frame Spacing	27.00 LB
F49296	CB 415 15' Frame Spacing	35.00 LB

## DOUBLE-HOLE CROSS BRACES - 36" AND 48" STUD CENTERS

Product Code	Description	Weight
FSW894013	DHCB - 3,4' x 4' - 4' Frame Spacing \$ 20.79 EA 9.61 LB	
FSW894012	DHCB - 3,4' x 5' - 5' Frame Spacing \$ 23.31 EA 10.75 LB	
FSW894011	DHCB - 3,4' x 6' - 6' Frame Spacing	12.36 LB
FSW894010	DHCB - 3,4' x 7' - 7' Frame Spacing	13.20 LB
FSW894009	DHCB - 3,4' x 8' - 8' Frame Spacing	13.81 LB
FSW894008	DHCB - 3,4' x 10' - 10' Frame Spacing	17.40 LB



The Screw Jack provides a maximum extension of 27 1/4". Screw Jacks are plated to help prevent rust and assure reliability. Screw Jacks are plated to help prevent rust and assure reliability.

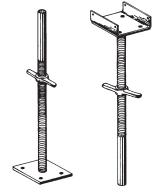

A U-Head Adapter and Screw Jack can be bolted together to create an adjustable top support for stringers or beams.

#### FF JACKS, U-HEADS AND BASE PLATE ACCESSORIES

Product Code	Description	Weight
F49823	Meter Screw Jack	20.65 LB
F49820	HD Base Plate 8" x 8" (no new rental adds)	8.00 LB
F49825	8" x 8" U-Head Adapter (discontinued)	8.30 LB
F49828	8" x 8" 7-hole U-Head (for MSJ and SFST)	6.93 LB
F31411	1/2" - 13 Hex Nut	0.10 LB
F49978	Attachment Screw	0.10 LB
F78170	SF/FF Sloping Head Assembly	12.50 LB

#### OTHER ACCESSORIES

Product Code	Description	Weight
127168	A Guardrail Bracket (former F12901041)	28.30 LB
F36465	Nailer Clip - Joist to Steel (no new inventory)	0.10 LB
F36641	Multiple Beam Nailer Clip (Joist to Aluminum)	0.10 LB
F49985	Steel Beam Clamp (Stringer to U-Head)	2.00 LB
F60138	1/2" Friction Clamp Bolt	0.20 LB
45600	1/2" Coil Nut (formerly PC 31616 1/2" Contour Nut)	0.06 LB
F48332	Timber Nailer Plate (2-3/8" tube)	1.55 LB
F49250	HD Stud Clamp	1.65 LB

#### REPAIR ACCESSORIES

Product Code	Description	Weight
F48343	Meter Screw Jack Retrofit Handle	1.57 LB
F49758	Posilock Assembly	0.50 LB
F903004	Speedlock Assembly	0.44 LB P

Heavy-duty Coupling Pins align and connect frames on multi-tier shore tower assemblies.

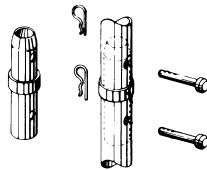

#### COUPLING PINS (DO NOT MIX THE TWO STYLES)

Product Code	Description	Weight
F49213	FF Coupling Pin - 1/2" dia holes (no new rental adds)	1.45 LB
F36650	1/2" x 3-1/2" Attachment Pin	0.24 LB
F36653	Hair Pin Clip	0.02 LB
FSW894014	SW Load Connector Pin - 5/8" dia holes (no new rental adds)	2.00 LB
FSW894016	SW Rivet Pin 5/8" x 3"	0.50 LB
FSW894015	SW Hitch Pin	0.30 LB
F49180	FF/SW Coupling Pin	1.80 LB

#### SPACER BARS

Product Code	Description	Weight
F49225	12" Spacer Bar (no new inventory available)	1.00 LB
F49224	18" Spacer Bar (no new inventory available)	1.50 LB
F49223	24" Spacer Bar (no new inventory available)	2.00 LB
F48436	Multiple Hole Spacer Bar	2.70 LB

#### FF/SW ACCESSORIES

Product Code	Description	Weight
F49730	FF/SW Base Plate	7.98 LB



# SHORES AND SUPPORTS

## Shoring Scheme Keeps Things Simple

W. F. Johnston Construction is a veteran constructor of below-grade circular tank walls, pile caps and slabs. Looking to expand their services, they bid on a job to build raised concrete platforms for compressed gas tanks at the Ball Foster facility in Burlington, Wisconsin.

In their search for a system to form the platform, they talked to many competitive forming manufacturer representatives. Wary of the complex suspended formwork systems pitched to them, they asked Symons by Dayton Superior for suggestions for forming this element more simply. As long-time Symons customers, they knew they could rely on Symons to help them evaluate their options more fully.

Symons recommended a simple, straight-forward solution that featured heavy duty FrameFast shoring frames supporting I-Beams for the plywood slab forms. Detailed plans were drawn up showing shoring layouts and the recommended plywood placement for the project.



Posilock offers quick assembly and dismantling advantages with a gravity locking feature.

When the contractor received the equipment, they were impressed with how quickly the crew was able to learn the new operations. With shoring frames laid out in a simple grid pattern, it was easy for the crew to set up and understand, maximizing productivity almost immediately.

The F. W. Johnston Construction Company reports that the crew was able to pour the concrete for the platform ahead of schedule and that the customer was satisfied with the structure. The contractor credits the simple, detailed plans with ensuring the success of this important first elevated slab project.



With detailed plans to guide them, the crew was able to quickly set up the shoring system and finish the raised platform ahead of schedule.



F. W. Johnston Construction felt confident that the success of their first raised platform project helped them expand their business.

## Garage Beam System

The Garage Beam System is a complete forming system designed specifically for post-tensioned beam and slab multi-story parking structures. It is the one forming package that can solve all of your cast-in-place garage forming and estimating problems—and help you make more money!

A detailed proposal shows all of the components required, suggested pour sequence and pour schedule, and estimated labor requirements. Symons by Dayton Superior provides the necessary beam form, temporary support, deck system, formwork handling equipment (gas or electric forklifts) and application instructions for efficient concrete placement.

### Advantages include:

- Identifies “true” lower cost of formwork
- Minimizes labor requirements
- One-time initial build-up to start
- Detailed application drawings
- Form sequence procedures
- Speeds positioning and setting
- Reduces stripping and moving time
- May eliminate crane-handling
- High quality concrete finish

### Features and Benefits

The Garage Beam system includes design and structural recommendations that simplifies formwork and reduces overall concrete construction costs. The system consists of long (up to 60') beam form assemblies that include high-capacity supports, column and capital forms and deck forming panels. All of these components



are stripped and moved to the next pour position with supplied forklifts and special moving dollies. The Garage Beam System includes application drawings and a pour sequence schedule that makes concrete forming operations highly productive.

### Garage Beam System (GBS):

- Requires no tie systems
- Requires no incidental bracing
- Drafted sides ease stripping
- Produces smooth concrete finish

Each component has an integrated design for maximum forming and labor productivity. Beam forms have 3/16" steel faces for strength, durability and excellent concrete finish. Deck panels are field-fabricated using wood “I” joists and high-density overlay (HDO) plywood to produce a consistent, smooth concrete finish. Long-span deck panels allow larger drive aisles for movement and to reduce labor and handling.

# SHORES AND SUPPORTS

## How the System Works

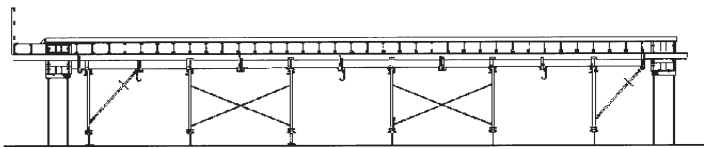

Concrete placement position—load frames extended

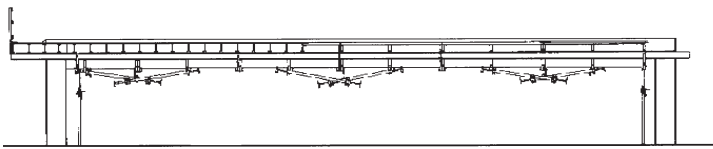

Prepared for stripping—load frames retracted  
(Beam dollies and forklifts not shown)

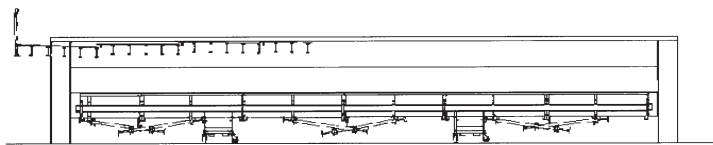

Ready for transport—beam form lowered on dollies

## Placement Position

Long span deck panels allow for large, clear work spaces for accessibility and mobility of forklifts. Prior to actual forming, site-fabricated deck panels and long sections of beam forms are site-assembled before concrete placement, to speed the production cycle.

## Prepared for Stripping

Load frames are hinged up and held with frame hooks. Beam dollies are attached to forklifts and brought up to the under side of the beam. The beam is stripped using hydraulic jacks and lowered to the floor with the forklifts.

## Ready for Transport

Deck panels remain suspended by deck panel bolts as the beam form is lowered. Beam forms are towed to the next pour position and moved into place with forklifts. Deck panels are then lowered on dollies and moved to the next pour. This procedure eliminates the need for alternate storage and reduces lag-time.

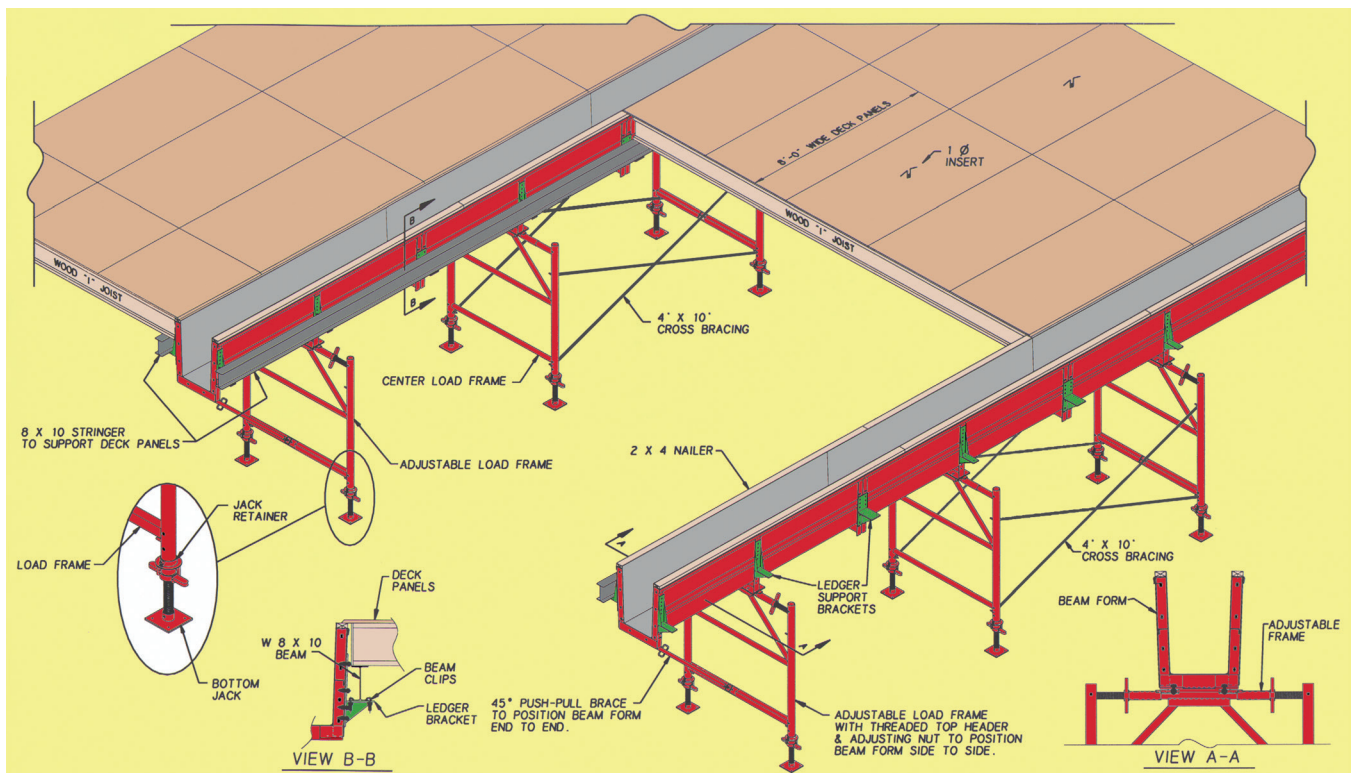

## Garage Beam System, continued

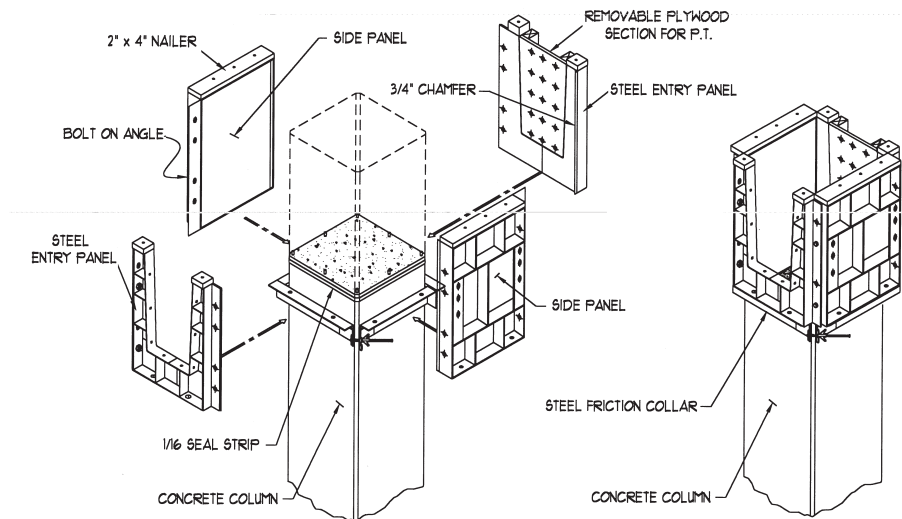

### Standard Capital Forms

All-steel capital forms are designed specifically for typical exterior and “pass-through” interior locations. Forms are steel-faced to produce smooth concrete and include steel chamfer to facilitate stripping and improve finish. Provisions for post-tension cable penetrations are also included in the capital form design.

Capital forms are usually supported by steel friction collars, eliminating the need for independent shoring support and simplifying setting procedures.

For low reuse applications, capital forms can be field-fabricated with plywood and lumber, according to fabrication details provided.

Formwork details are available for special beam intersections, ramp capitals, and other unique applications to meet the production goals for almost any specific project.



### Ramp Capital Forms

Ramp capitals are located at column and beam intersections on ramps. These post-tensioned beams often intersect this area at different elevations on opposite sides of the column. These variations typically cause ramp capital forms to be built on-site with supplied field fabrication drawings. Ramp capitals consist of plywood and dimensional lumber (supplied by contractor) and steel entry panels from Symons. Ramp capitals are assembled with swing bolt hardware that speeds stripping and resetting procedures. Ramp capitals are supported using steel friction collars.

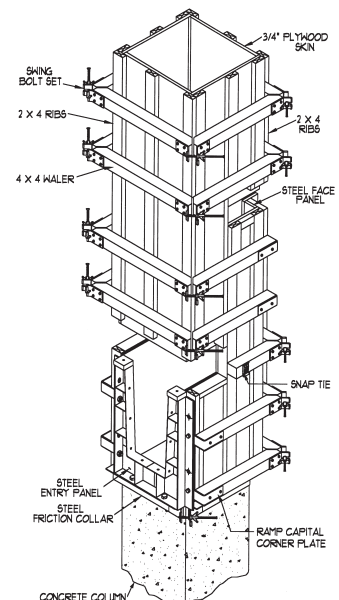

# SHORES AND SUPPORTS

## Symons is the Best Buy

Best Buy contracted with architects Perkins & Will and Opus Architects & Engineers to design a new corporate headquarters to consolidate their operations which were scattered around the Minneapolis area.

The 1000 foot long Hub links the four office towers to the 7,000 car, 2 million sqft, five-level parking ramp.

Symons supplied Opus with many of the forming systems and many of the forming solutions on this project. The local Symons branch was also a plus being only two miles away from the job site.

Aluminum Beam gangs were used to form the foundation walls for all structures. Gang heights varied from 13' to 25' high and 10' to 20' long, with pilasters poured monolithically with the wall. With a tight construction schedule, Opus assigned one Superintendent per building and cycled the gangs from one structure to the next on a 4-5 week schedule per building.

Opus had never used the Garage Beam System (GBS) before, but it didn't take long for them to get things up and running smoothly. Approximately 108,000 sqft of equipment was cycled to create each of the structures five 340,000 sqft levels. Floor height was typically 11' from level to level, the 60' long beam sections were 18" wide x 32" high. All GBS components are easily handled with forklifts and wheeled dollies for maximum productivity, an important consideration since Opus scheduled one pour per week for a year. The ramp required 22,500 deck anchors for the deck panels, and twenty 55 gallon drums of form release for the beams and deck. Nearly 4,000 6"x6" Douglas fir timber re-shore posts were used for re-shoring the slabs.

Opus was extremely pleased with the outcome of this job and the relationship they established with Symons. They were especially impressed with the professionally detailed drawings that accompany the GBS system. With the success of this job, Opus has approached Symons to supply GBS for all their parking garages.



Photo by Bordner Aerials  
8/14/02

The two million sqft parking structure, one of the largest privately owned ones in the world, was the first time Opus used the Garage Beam System.



Opus achieved one pour per week to complete the two million sq. ft. parking structure.





Delays early in site preparation meant that parking garage construction began late, threatening timely completion.



Deck forms were already built and ready to use when conditions were right to build the parking garage ramps and decks.

## More Parking for Tight Site

W.E. O'Neil Construction Company was contracted to build a 500,000 square foot, 6-story parking garage at Evanston Hospital. As a long-time customer, with plenty of experience using the Garage Beam System for similar structures, they knew they could count on Symons by Dayton Superior to provide the equipment and support necessary for this large project.

Several construction projects occurring simultaneously at the hospital, created restrictions related to site access and equipment storage. The contractor asked Symons to come up with a plan that minimized the amount of materials and maximize reuse so that storage difficulties would be reduced.

Early unforeseen delays in demolishing an existing parking garage and pile driving for the new structure created a very tight construction schedule for subsequent construction. In addition, harsh weather conditions contributed to contractor concerns.

Project Manager Gary Stratman and Superintendent Pat Ridge were concerned that these delays would cause them to miss the deadline by an unacceptable margin and push them over budget.

To address both of these concerns, Symons recommended that the contractor accept a partial shipment of wood joists so that deck panels could be pre-built. This plan allowed the contractor to delay shipment of the steel beam forms and supporting frames until they were actually needed, minimizing rental costs.

By early December, the contractor had completed demolition and preliminary construction work. This early stage included using the Versiform® forming system for the foundation walls, with some of the gangs measuring up to 38' high. In addition, the specified 30" x 30" concrete columns for the parking garage were formed with the Steel-Ply® forming system.

On December 15th, the first deck pour was made with the Garage Beam System. W.E. O'Neil reported that the detailed plans provided by Symons and the efficiency inherent in the Garage Beam System allowed them to make up for lost time.

# SHORES AND SUPPORTS



The strong and adjustable load frames with wide deck panels allowed large, clear work spaces for easy accessibility.



Fork Lifts position steel beam forms between columns, and then workers lower the attached support frames.



The site was too tight for much crane access, but the Garage Beam System components are placed with forklifts.

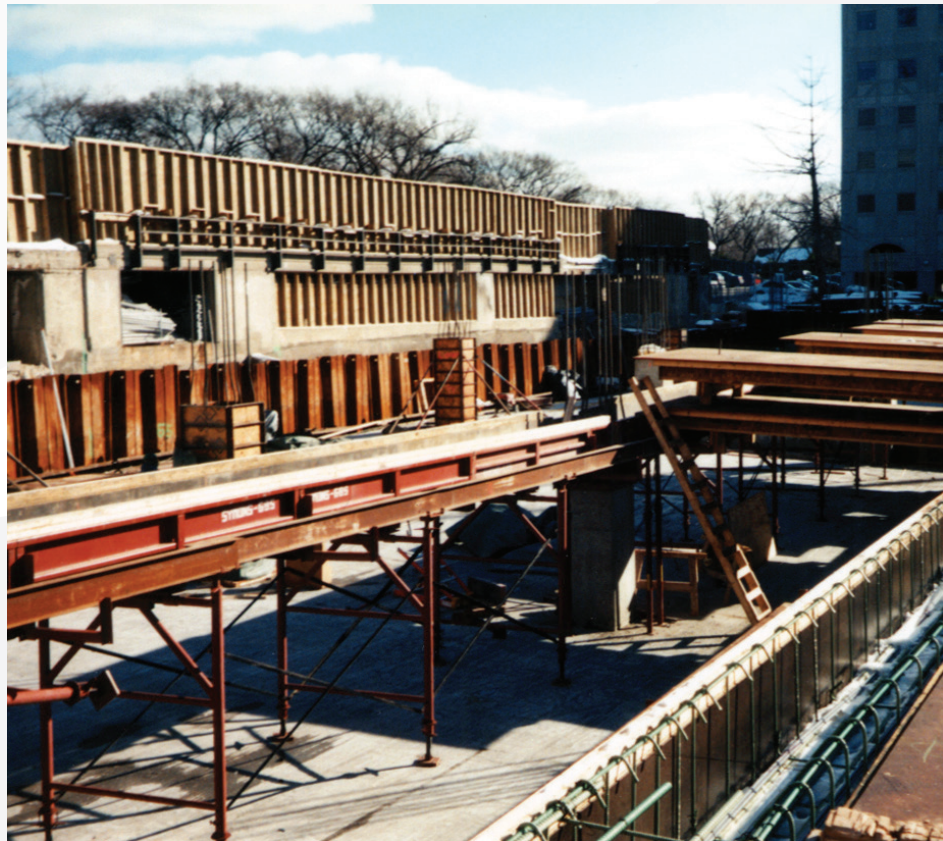

The pre-built deck panels span between the beam forms.

## ShorFast™ Shoring

Lightweight legs, jacks and frames provide high-strength shoring support.

### Leg assembly

The leg assembly is extruded with four large keyways for the frame attachment and provides a positive rigid connection. The top and bottom plates are aluminum castings that can be bolted together with a larger center hole to accept the jack.

Size		Weight	
m	ft-in	kg	lbs
0.5	1'-7"	4.0	8.8
1.5	4'-11"	10.0	22.0
2.0	6'-6"	13.0	28.6
2.5	8'-2"	17.0	37.4
3.3	10'-10"	21.7	47.9
4.0	13'-2"	26.0	57.2

### Jack assembly

The jack collar has a self-cleaning thread that allows smooth adjustment to the required height. The base casting has location holes to connect Trigger Braces to the ShorFast Frames when needed.

Size		Weight		Range
m	in	kg	lbs	in
1.1	43"	8.0	17.6	5"-32"
1.6	63"	11.7	25.7	7"-52"

### Frame design

The three frame sizes are extruded with a location key that fits neatly into the leg providing a rigid and secure connection. They are attached to the leg using four "T" bolts and hand tightened with a large cast collar. The top strut is a special-shape extrusion to support the access walks and edge beams.

Size		Weight	
m	ft-in	kg	lbs
1.0	3'-3"	9.0	19.8
1.83	6'	14.15	31.2
2.0	6'-7"	13.0	28.6
2.44	8'	17.14	37.8
3.0	9'-10"	15.5	34.1



# SHORES AND SUPPORTS

ShorFast is a light-weight, high-strength aluminum shoring system which is easy to assemble and move yet versatile enough to shore almost any concrete structure. The system can be ganged together, rolled to the edge of a building and flown to the next level maximizing floor cycling and crew efficiency. To get the most out of ShorFast use the system in high-bay areas, sloped conditions or repetitive floor cycles on the same project.

## SHORFAST LEGS AND JACKS

Product Code	Description	Weight
F19700	ShorFast Leg 1.5 M (4'-11")	22.00 LB
F19701	ShorFast Leg 2.0 M (6'-6")	28.60 LB
F19702	ShorFast Leg 2.5 M (8'-2")	37.40 LB
F19707	ShorFast Leg 3.3 M (10'-10")	47.90 LB
F19754	ShorFast Leg 4.0 M (13'-2")	57.00 LB
F19703	ShorFast Leg 0.5 M (1'-7")	9.94 LB
F19704	ShorFast Jack 1.6 M (5'-3") H&B	25.70 LB
F19705	ShorFast Jack 11 M (3'-7") H&B	17.60 LB
F78101	ShorFast Plastic Washer for Jack	0.05 LB
F19706	ShorFast Jack Retainer	2.20 LB
F19729	ShorFast Spanner	5.50 LB

## SHORFAST FRAMES

Product Code	Description	Weight
F19721	ShorFast Frame 1.0 M (3'-3")	19.68 LB
F19781	ShorFast Frame 1.83 M (6')	31.20 LB
F19722	ShorFast Frame 2.0 M (6'-6")	28.60 LB
F19782	ShorFast Frame 2.44 M (8')	37.80 LB

Product Code	Description	Weight
F19723	ShorFast Frame 3.0 M (9'-10")	34.10 LB

## SHORFAST BEAMS

Product Code	Description	Weight
F78108	ShorFast™ Tee Bolt (Imperial)	0.30 LB
F19711	ShorFast™ Beam 1.0 M (3'-3")	19.10 LB
F19712	ShorFast™ Beam 2.0 M (6'-6")	38.30 LB
F19713	ShorFast™ Beam 3.0 M (9'-10")	57.40 LB
F19714	ShorFast™ Beam 4.0 M (13'-1")	76.60 LB
F19715	ShorFast™ Beam 5.0 M (16'-4")	95.70 LB
F19716	ShorFast™ Beam 6.0 M (19'-8")	115.50 LB
F19717	ShorFast™ Beam 2.4 M (7'-10")	46.00 LB
F19718	ShorFast™ Beam 3.6 M (11'-9")	68.90 LB
F19720 S	ShorFast™ Beam 5.4 M (17'-8")	103.40 LB
F19719	ShorFast™ Beam 4.8 M (15'-9")	92.00 LB
F19731	ShorFast™ Beam 7.2 M (23'-7")	137.70 LB
F19741	ShorFast Beam 9.6 M (31'-6")	179.50 LB
F19755	ShorFast™ Beam 5.8 M (19'-0")	110.80 LB
F19751	ShorFast™ Beam 1.2 M (3'-11")	22.90 LB
F19741	ShorFast™ Beam 9.6 M (31'-6")	179.50 LB
F36502	Beam Attachment Clamp	0.31 LB
F31411	1/2" - 13 NC Hex Nut	0.10 LB

## FRAME REPAIR

Product Code	Description	Weight
F78107	ShorFast Cast Fly Nut (imperial)	0.40 LB
F78108	ShorFast Cast Tee Bolt (imperial)	0.30 LB
F78109	Telltale Ring	0.00 LB



## SHORFAST ACCESSORIES

Product Code	Description	Weight
F49828	8" x 8" 7-hole U-Head Adapter (for MSJ and SFST)	6.93 LB
F19744	ShorFast No. 2 Trigger Brace (45"-76")	17.70 LB
F19745	ShorFast No. 1 Trigger Brace (32"-51")	13.39 LB
F19709	ShorFast Frame Brace Lug	1.80 LB
F19742	ShorFast Trigger Brace Bracket	2.40 LB
F19708	ShorFast Wheel Assembly	27.10 LB
F19733	ShorFast Wheel Assembly Long	46.72 LB
F19738	ShorFast Toe Board Bracket	0.40 LB
F19739	ShorFast Guardrail Bracket	2.70 LB
F78170	SF/FF Sloping Head Assembly	12.50 LB
F36085	5/8" Fit-Up Nut	0.07 LB
F31615	5/8" x 2" Fit-Up Bolt	0.22 LB
F78161	ShorFast 1/2" Thick Header Plate Washer	1.60 LB
F19760	1.90" O.D. Std. Pipe x 4'	10.90 LB
F19761	1.90" O.D. Std. Pipe x 6'	16.40 LB
F19758	1.90" O.D. Std. Pipe x 7'	19.00 LB
F19762	1.90" O.D. Std. Pipe x 8'	21.80 LB
F19759	1.90" O.D. Std. Pipe x 14'	38.10 LB
F60025	21' Pipe Waler	63.00 LB
F19690	ShorFast Lifting Frame Assembly	2,420.00 LB
F19752	ShorFast Jack Rack	64.00 LB
F19753	ShorFast Accessory Bin	147.00 LB
F4178157	ShorFast Sample Kit	4.60 LB

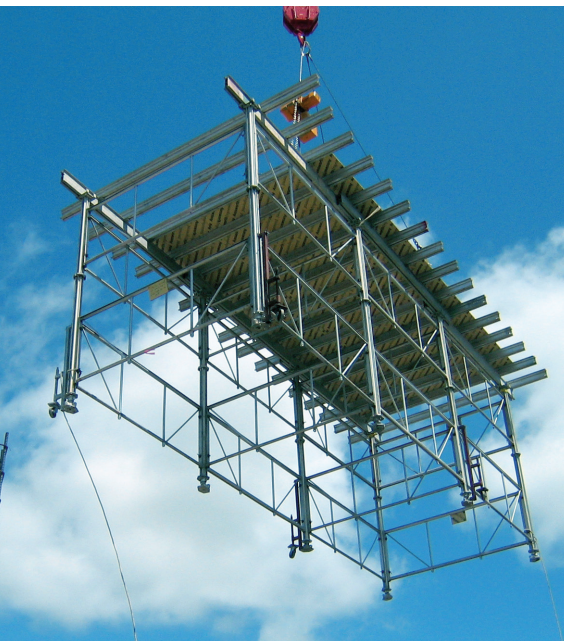



## Building a Landmark

The Gaylord National Resort and Convention Center, located on the Potomac River near Washington, D.C. is the first phase of the National Harbor project. The centerpiece of the project is a 42 acre parcel of land that will include over 1,500 hotel rooms, 100 suites, a 500,000 square foot convention center and parking garages. The \$565 million dollar resort had been in the planning stages for years.

When McClone Construction was awarded the contract to build the hotel, Symons was well prepared. The hotel consisted of five buildings between 15 to 25 stories apiece requiring multiple truckloads of shoring material each.

As if building the hotel wasn't enough, McClone was also the successful bidder for the second phase, the construction of the Convention Center. This phase of the project consisted of nearly 500,000 square feet of elevated beam and slab as high as 40'. With typical beam sizes 36" wide and 48" deep, and bay sizes of 60' x 60', this seemed like a large parking garage. When meeting with McClone, it was determined that they would pre-build all of the beam soffits in gangs and utilize deck panels similar with a support system that could be flown from pour to pour. With concrete loads as high as 26 kips/leg, coupled with heights of 40', Symons determined that ShorFast could carry the loads.

The design required ShorFast towers to support the concrete beams from a saddle beam (8" double channel waler) that was an integral part of the beam soffit and screw jacks to support the deck panels. Once a deck was completed, the ShorFast towers would be moved to the next pour, the beam soffits and sides removed and repositioned as units, and the deck panels were also stripped and moved.

The contractor credits the success of the project to the adaptability and strength of the shoring system and the large volume of equipment that Symons was able to provide. The construction scheme went according to plan, with the Grand Opening in April 2008.



# SHORES AND SUPPORTS



The luxurious Gaylord National Resort and Convention Center (above) is the centerpiece of the National Harbor project (right), just outside of Washington, D.C. (Rendering courtesy of Gaylord Hotels.)

## Space-Lift™ Support System

Productive jump form system for structures with core walls and shear walls.

The Space-Lift system is a fully-engineered jump form system intended for concrete shear wall applications. The system consists of frame components and a carriage assembly that supports the forming equipment and work crew.

The Space-Lift assembly is suspended from Jump shoes that are bolted to inserts in the concrete wall. The entire assembly remains anchored to the wall during the forming operation. Work platforms provide safe access during setting, placing, stripping and finishing activities. Rollback carriages allow the gang form to be retracted from the wall without being removed. All these activities, of course, proceed without using valuable crane time.

### Highlights

- Standard Space-Lift frame heights of up to 16' for higher walls in lobby and atrium areas
- Space-Lift frame spacing up to 10' o.c. adapts to structure and gang form requirements
- The patented Lift Lock provides resistance to uplift forces resulting in a safer work environment.
- Rollback form access ranges from 35" with Steel-Ply to 29" with Aluminum Beam Gangs
- Trailing platform makes operations such as removing Jump Shoes, patching and welding easy and safe
- The unique Curved Wall Bracket provides angled adjustment for Space-Lift frames on tank applications with a minimum 11' radius.
- Work platform provides ample room for crews to set, strip and clean forms
- The patented Carriage Lock ensures the forms are locked in place during use and form cycling.

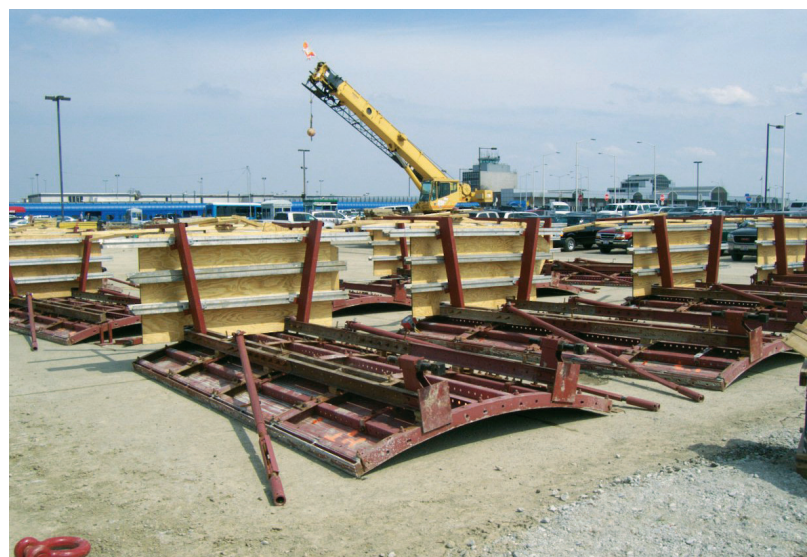

# SHORES AND SUPPORTS

Space-Lift is a fully-engineered roll-back jump system designed for multi-lift concrete structures. The system consists of frame components and a carriage assembly that safely supports your crew and virtually any type of form system including radius formwork. The entire assembly remains anchored to the wall during the forming operation while the 9ft wide work platforms provide safe access during setting, placing, stripping, and finishing activities. The rollback carriages allow the formwork to be retracted from the wall without being removed. All of these activities proceed without using valuable crane time.

## SPACE-LIFT SYSTEM

Product Code	Description	Weight
F51200	Swivel Lift Bracket	20.70 LB
F51209	Pier Cap Waler Brace Bracket	12.00 LB
F51215	Space Lift - Carriage Assembly	337.90 LB
F51221	Space Lift - Tie Back Bumpers	4.90 LB
F51231	Space Lift - Swivel Tube Clamp	5.00 LB
F51232	Space Lift - Carriage/ Waler Bracket	49.20 LB
F51235	Space Lift - Kick Tube	17.00 LB
F51236	Space Lift - Jump Shoe (3 Req'd)	27.80 LB
F51237	Space Lift - Tie Back	0.00 LB
F51239	Space Lift - Frame Diagonal	53.20 LB
F51240	Form Shear Platform	24.00 LB
F51242	Access Walkway Bracket	62.30 LB
F51243	Access Walkway Guard Post	23.80 LB
F51310	Space Lift - 10' Frame Leg	198.19 LB
F722110	4 x 6 Plate and Nut	2.79 LB
F51367	Space-Lift Carriage Wrench	5.00 LB
F51246	Curved Wall Bracket	4.10 LB
F19758	Pipe 7'	19.00 LB
F19759	Pipe 14'	38.10 LB
F39979	67-1/2" Brace	42.00 LB
F39980	85-1/2" Brace	46.15 LB
F39981	56" Extension	15.72 LB
F39982	92" Extension	27.00 LB
F51304	Space Lift - 4' Frame Leg	92.75 LB
F51308	Space Lift - 8' Frame Leg	165.68 LB
F51396	3/4" x 5" Long Pin	0.94 LB

## ANCHORS

Product Code	Description	Weight
F51399	Set Back Cone	0.50 LB P
40547	Galvanized 1" x 5-1/2" Expanded Coil Insert	1.35 LB P
F51382	Setting Bolt - 1" Dia 4-1/2" Long	0.30 LB P
125698	1" x 4" Coil Bolt	0.96 LB P



## Steel Form Support Systems

Symons offers the widest range of standard and rentable support options in the concrete construction industry! Combined with our custom capabilities for extreme loads and unique structures, we can provide safe and efficient support solutions for virtually any condition.

### Max-A-Form STS Support 300K SUPPORT SYSTEM

Product Code	Description	Weight
F1408000	300 Kip Support Bracket	1,610.20 LB
F1408100	300 Kip Sand Jack (Bottom)	47.00 LB
F1408105	300 Kip Sand Jack (Top)	140.70 LB
F1408200	300 Kip Spreader Beam	951.10 LB
F1408300	300 Kip Column Adapter 9'-11"	1,150.00 LB
F1408310	300 Kip Column Adapter 7'-9"	1,150.00 LB
F1408320	300 Kip Column Adapter 6'-7"	1,150.00 LB
F1408400	300 Kip Thru Bolt Sleeve x 1'	36.20 LB
F1408410	300 Kip Thru Bolt Sleeve x 6"	30.91 LB
F1408420	300 Kip Thru Bolt Sleeve x 2'	53.00 LB
F1408430	300 Kip Thru Bolt Sleeve x 3'	69.90 LB
F1408500	3" Dia. Thru Bolt x 12'	304.30 LB
F1408510	3" Dia. Thru Bolt x 8'-10"	228.17 LB
F1408520	3" Dia. Thru Bolt x 14'	352.30 LB
F47914	3" Dia. Hvy Hex Nut N.C. 2H	9.50 LB
F1408900	Steel Shim Pack Kit	25.00 LB P
F1408910	12' Length - 300K Imbed	29.52 LB P
F1408920	8' Length - 300K Imbed	19.19 LB P
F1408930	6' Length - 300K Imbed	13.96 LB

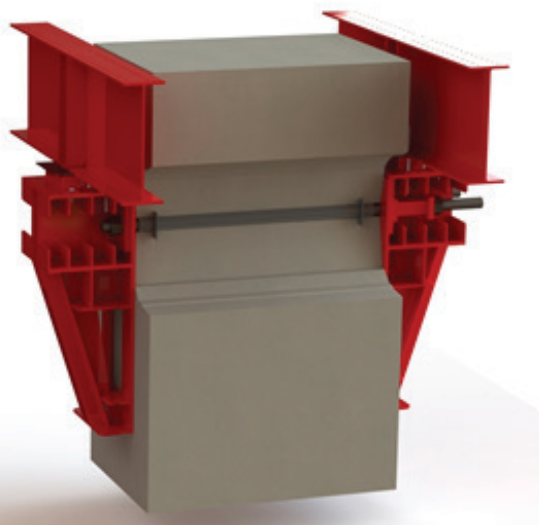

### Max-A-Form Anchor Brackets

#### ANCHOR BRACKET

Product Code	Description	Weight
F39974	140 Kip One-Position Bracket	188.00 LB
F39994	140 Kip Rev Two-Position Bracket	303.00 LB
F39815	140 Kip Offset Bracket	910.00 LB
F39816	140 Kip Bearing Plate	22.00 LB
F39978	140 Kip Screw Jack	138.00 LB
F39650	140 Kip Screw/Sand Jack	173.00 LB
F39970	140 Kip Spreader Beam	516.00 LB
F39976	140 Kip Multi-Purpose Spreader Beam	200.00 LB
F39971	140 Kip Brace	65.00 LB
F39638	3/4" dia Hold Down Rod (24")	2.00 LB
F39973	70 Kip One-Position Bracket	70.00 LB
F39995	70 Kip Three-Position Bracket	155.00 LB
F39069	70 Kip One-Bolt Two-Position Bracket	130.00 LB
F39071	40 Kip Washer Plate	13.00 LB
F39890	70 Kip Offset Anchor Bracket	199.00 LB
F39891	70 Kip Bearing Plate	50.00 LB
F39977	70 Kip Screw Jack	90.00 LB
F39651	70 Kip Screw/Sand Jack	125.00 LB
F39969	70 Kip Spreader Beam	93.00 LB
F39638	3/4" dia Hold Down Rod (24")	2.00 LB

### Max-A-Form Anchor Clamps

#### ANCHOR CLAMPS

Product Code	Description	Weight
F39884	40 Kip Anchor Clamp	155.72 LB
F39071	40 Kip Washer Plate	13.00 LB
F38049	25 Kip Anchor Clamp	59.00 LB
F39972	25 Kip Long Anchor Clamp	107.00 LB
F39814	25 Kip Roller Assembly	16.00 LB
F39916	12K Anchor Clamp	36.00 LB
F39640	12K Washer Plate	4.00 LB

### Max-A-Form Thru-Bolts and Imbeds

#### THRU-BOLT W/ NUT

Product Code	Description	Weight
F39869	2" x 10'-8" Thru-Bolt w/Nut	120.00 LB
F39868	2" x 9'-8" Thru-Bolt w/Nut	109.00 LB
F39867	2" x 8'-8" Thru-Bolt w/Nut	99.00 LB
F39866	2" x 7'-8" Thru-Bolt w/Nut	88.00 LB
F39865	2" x 6'-8" Thru-Bolt w/Nut	77.00 LB
F39864	2" x 5'-8" Thru-Bolt w/Nut	67.00 LB
F39863	2" x 4'-8" Thru-Bolt w/Nut	56.00 LB
F39862	2" x 3'-8" Thru-Bolt w/Nut	45.00 LB
F39861	2" x 2'-8" Thru-Bolt w/Nut	35.00 LB
F39860	1-1/2" x 10'-6" Thru-Bolt w/Nut	66.00 LB
F39859	1-1/2" x 9'-6" Thru-Bolt w/Nut	60.00 LB
F39858	1-1/2" x 8'-6" Thru-Bolt w/Nut	54.00 LB
F39857	1-1/2" x 7'-6" Thru-Bolt w/Nut	48.00 LB
F39856	1-1/2" x 6'-6" Thru-Bolt w/Nut	42.00 LB
F39855	1-1/2" x 5'-6" Thru-Bolt w/Nut	36.00 LB
F39854	1-1/2" x 4'-6" Thru-Bolt w/Nut	30.00 LB
F39853	1-1/2" x 3'-6" Thru-Bolt w/Nut	24.00 LB
F39852	1-1/2" x 2'-6" Thru-Bolt w/Nut	18.00 LB
F39877	2" Thru-Bolt Nut	0.40 LB
F39876	1-1/2" Thru-Bolt Nut	0.30 LB

#### MAX-A-FORM 140 KIP IMBEDS

##### INSIDE STRIPPING CORNERS (DOUBLE DUTY)

Product Code	Description	Weight
F39851	9' Length - 140 Kip Imbed	22.18 LB
F39850	8' Length - 140 Kip Imbed	20.54 LB
F39849	7' Length - 140 Kip Imbed	18.90 LB
F39848	6' Length - 140 Kip Imbed	17.26 LB
F39847	5' Length - 140 Kip Imbed	15.62 LB
F39846	4' Length - 140 Kip Imbed	13.98 LB
F39845	3' Length - 140 Kip Imbed	12.34 LB
F39844	2' Length - 140 Kip Imbed	10.70 LB
F39843	1' Length - 140 Kip Imbed	9.06 LB
F39104	2" Imbed Cap	0.20 LB

# SHORES AND SUPPORTS

## MAX-A-FORM 70 KIP IMBEDS

INSIDE STRIPPING CORNERS (DOUBLE DUTY)

Product Code	Description	Weight
F39842	9' Length - 70 Kip Imbed	46.00 LB
F39841	8' Length - 70 Kip Imbed	41.00 LB
F39840	7' Length - 70 Kip Imbed	37.00 LB
F39839	6' Length - 70 Kip Imbed	32.00 LB
F39838	5' Length - 70 Kip Imbed	11.50 LB
F39837	4' Length - 70 Kip Imbed	23.00 LB
F39836	3' Length - 70 Kip Imbed	19.00 LB
F39835	2' Length - 70 Kip Imbed	14.00 LB
F39834	1' Length - 70 Kip Imbed	10.00 LB
F39103	1½" Imbed Cap	0.10 LB

## MAX-A-FORM 40K IMBED

SINGLE TUBE FOR 2" THRU-BOLTS

Product Code	Description	Weight
F39899	9' Length - 40 Kip Imbed	7.11 LB
F39898	8' Length - 40 Kip Imbed	6.29 LB
F39897	7' Length - 40 Kip Imbed	6.13 LB
F39896	6' Length - 40 Kip Imbed	5.47 LB
F39895	5' Length - 40 Kip Imbed	3.83 LB
F39893	4' Length - 40 Kip Imbed	3.01 LB
F39888	3' Length - 40 Kip Imbed	2.19 LB
F39887	2' Length - 40 Kip Imbed	1.37 LB
F47409	1' Length - 40 Kip Imbed	0.55 LB
F39104	2" Imbed Cap	0.20 LB

## MAX-A-FORM 25K IMBED

SINGLE TUBE FOR 1½" THRU-BOLTS

Product Code	Description	Weight
F39833	9' Length - 25 Kip Imbed	6.33 LB
F39832	8' Length - 25 Kip Imbed	5.60 LB
F39831	7' Length - 25 Kip Imbed	4.87 LB
F39830	6' Length - 25 Kip Imbed	4.14 LB
F39829	5' Length - 25 Kip Imbed	3.41 LB
F39828	4' Length - 25 Kip Imbed	2.68 LB
F39827	3' Length - 25 Kip Imbed	1.95 LB
F39826	2' Length - 25 Kip Imbed	1.22 LB
F39825	1' Length - 25 Kip Imbed	0.48 LB
F39103	1-1/2" Imbed Cap	0.10 LB

## Friction Collar Sets

### CIRCULAR FRICTION COLLAR SETS

- Order four 1"x11" A90 Thru-Bolts with eight A325 hardened washers and four 1" girder nuts. (Washers sold separately.)
- Use one 1-1/2" x 3'-6" Thru-Bolt 12" to 18" columns.
- Use one 1-1/2" x 4'-6" Thru-Bolt 14" to 30" columns.

Product Code	Description	Weight
F39172	72" Friction Collar Set	522.00 LB
F39160	60" Friction Collar Set	457.00 LB
F39154	54" Friction Collar Set	424.00 LB
F39148	48" Friction Collar Set	393.00 LB
F39142	42" Friction Collar Set	362.00 LB
F39136	36" Friction Collar Set	330.00 LB
F39134	34" Friction Collar Set	318.00 LB
F39132	32" Friction Collar Set	307.00 LB
F39130	30" Friction Collar Set	302.00 LB
F39128	28" Friction Collar Set	289.00 LB
F39126	26" Friction Collar Set	281.00 LB
F39124	24" Friction Collar Set	268.00 LB
F39118	18" Friction Collar Set	237.00 LB
F39112	12" Friction Collar Set	207.00 LB
F39977	70 Kip Screw Jack	90.00 LB
F31460	1" x 11" A490 Bolt	3.00 LB
F31633	1" Girder Nut (2H)	0.41 LB
F31457	1" Hardened Washer	0.10 LB

### RECTANGULAR FRICTION COLLAR SETS

- Order two 1-1/2" Thru-Bolts and four washers. (Washers sold separately.)
- Use two 1-1/2" x 3'-6" Thru-Bolts 12" to 18" columns.
- Use one 1-1/2" x 4'-6" Thru-Bolt 14" to 30" columns.

Product Code	Description	Weight
F39177	Rectangular Adj Friction Collar Set	319.00 LB
F39885	1-1/2" Hardened Washer	0.19 LB
F39853	1-1/2" x 3'-6" Thru-Bolt w/Nuts	24.00 LB
F39854	1-1/2" x 4'-6" Thru-Bolt w/Nuts	30.00 LB



## Symons® Drop-Head System

The Drop Head decking system is the most cost effective solution in today's marketplace. Experience 70% material recovery one day after pouring and a selection of posts with the widest height range in the industry. With color coded equipment and application drawings, its versatility and efficiency is designed around contractors' needs.

- **PRODUCT ADAPTABILITY** — 6'-8" to 12'-8" single post capacity. Up to 18" slabs can be supported. (Higher elevations can be reached using ShorFast posts and the ShorFast DropHead Adapter Plate F19757.)
- **LOWER FREIGHT COSTS** — 6000 Sq. Ft. of equipment can be loaded on a 40' flatbed.
- **LOWER MATERIAL COST** — 70% Material recovery 1 day after pouring possible.
- **EASE OF USE** — All parts are color coded to match Dayton Superior provided erection drawings.

Description	Quantity Per Pack	Weight Each	Weight Per Rack
Dayton Primary Post	50	73lbs	3733lbs
Dayton Primary Post with 2' Extension	50	88lbs	4483lbs
# 3 Drop Head Post	60	58lbs	3480lbs
10' Ledgers	33	67lbs	2311lbs
8' Ledgers	33	54lbs	1865lbs
6' Ledgers	33	41lbs	1436lbs
4' LVL Joist	68	14.5lbs	1069lbs
5' LVL Joist	68	15.5lbs	1137lbs
6' LVL Joist	68	18.5lbs	1341lbs
6' Aluminum Joist	50	18lbs	983lbs



Typical 40' flatbed truck with 6,000 sq. ft. of shoring.



# SHORES AND SUPPORTS

## DROP HEAD SYSTEM

Product Code	Description	Weight
F57050	6'-0 Ledger - Red	40.48 LB
F57051	8'-0 Ledger - Green	53.46 LB
F57052	10'-0 Ledger - Silver	67.32 LB
F57053	Storage Frame	83.00 LB
F57054	Large Storage Frame	114.00 LB
F57055	4'-0 LVL Joist w/2 clips - Black	14.50 LB
F57056	5'-0 LVL Joist w/2 clips - Blue	15.50 LB
F57057	6'-0 LVL Joist w/2 clips - Red	18.50 LB
F57058	6'-0 Aluminum Joist w/J-Catch - Orange	18.00 LB
F57060	Bracing Slider w/2 Jet-Loks	5.00 LB
F57062	4 x 8 Crossbrace	12.50 LB
F57063	4 x 6 Crossbrace	10.30 LB
F57064	4 x 5 Crossbrace	9.00 LB
F57065	4 x 4 Crossbrace	8.50 LB
F57066	Plastic Spud	0.10 LB P
F57067	Wire Basket for Cart	62.00 LB
F57068	Ledger to Drophead Clip	0.50 LB
F57069	Ledger Hold Down Clip	0.50 LB
F57070	Ledger to Ledger Clip	0.50 LB
F57071	Ledger Hangers (need 2 for set)	10.00 LB
F57073	Primary Post - Galvanized	58.50 LB
F57074	2' Extension for Primary Post	15.50 LB
F57075	#3 Post Shore - Galvanized	42.90 LB
F57079	Universal Drophead	15.00 LB
F57082	3/4" x 3" Bolt	1.10 LB
F57083	3/8" x 2" Pin w/Keeper	0.12 LB
F57084	14mm Bolt	0.20 LB
F57085	1/2" Twistlock Bolt w/Nut	0.30 LB
F57086	Loop Pin	1.44 LB
F57087	8" Fixed Caster	5.50 LB
F57088	8" Swivel Caster w/Full Break	5.50 LB
F57089	Caster Bolt Assembly 3/8" x 3"	0.84 LB
F57090	Jetlok w/Nut	0.10 LB
F57091	Panel Cart	62.00 LB
F57092	2'-0 x 6'-0 Panel (Powder Coat)	46.50 LB
F57093	2'-0 x 6'-0 Panel Wood Replacement	18.30 LB
F57094	3'-0 x 6'-0 Panel (Powder Coat)	62.70 LB
F57095	3'-0 x 6'-0 Panel Wood Replacement	24.60 LB
F57096	Panel to Ledger Safety Clip	2.50 LB
F57098	Safety/Warning Sticker	0.05 LB
F57099	Symons Sticker	0.02 LB
F19757	UDH Adapter Plate Requires (2) F19801; (2) F19768; (2) F19769	5.70 LB
F19768	M12 Nut	0.01 LB
F19769	M12 Washer	0.01 LB
F19800	T-Bolt Jet Lok	1.15 LB
F19801	14mm Bolt and Nut Ass'y	0.85 LB

## Ledger Color Codes



## LVL Color Codes

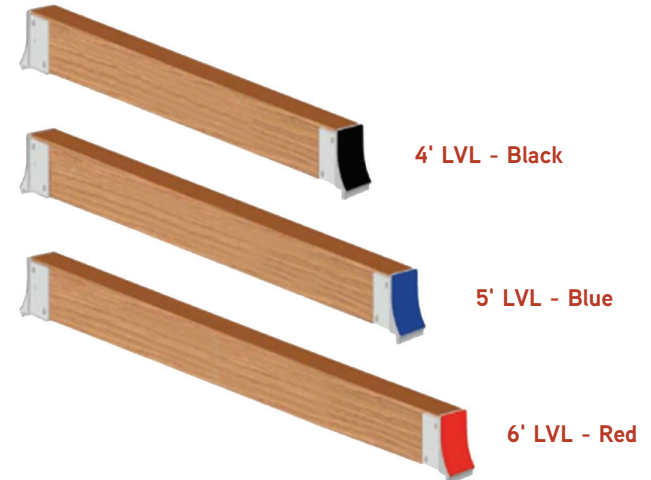

## Symons Soldier™ Soldier Beam

A versatile steel construction beam system for forming and shoring applications.

### Multiple use

A unique hole pattern makes the Symons Soldier adaptable to virtually any concrete forming or shoring application. When combined with the standard hardware and accessories, the Symons Soldier can be configured as a shore, brace, strongback, waler, truss or one of many other typical concrete forming system components.

### Design strength

Soldier beams are fabricated with high-strength steel to provide high load capability, yet they are surprisingly lightweight, resulting in reduced crane capacity requirements. End plates are built square to the beam, enabling a moment connection with four 3/4" Speed Bolts and Nuts. By bolting end-to-end as a continuous beam, the connection develops the full project design strength.

### Simple connections

The ability to quickly bolt to the flanges on any side adds to the efficiency of the Soldier. This feature allows the Soldier system to complement other standard Symons concrete forming systems for special applications.

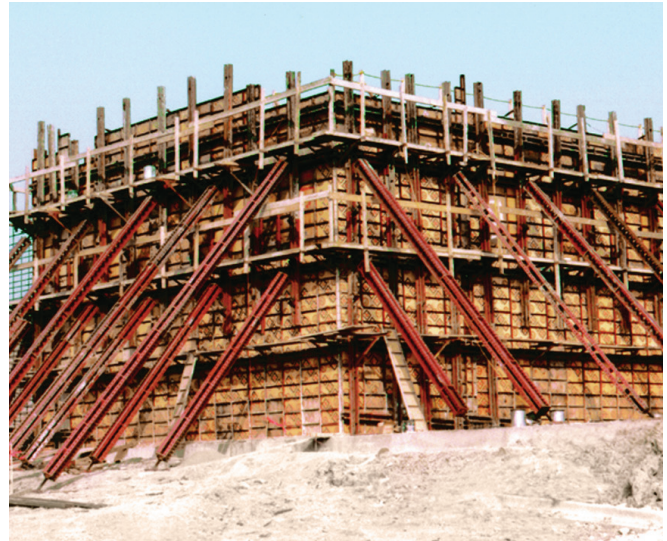

# SHORES AND SUPPORTS

The Symons Soldier system is a lightweight, yet extremely strong, construction beam system that is adaptable to almost any forming or shoring configuration with standard, rentable components and accessories. Symons developed a unique hole pattern which makes the Symons Soldier adaptable to almost any forming or shoring configuration with standard components and accessories.

## SOLDIER BEAMS

Product Code	Description	Weight
F38904	12'-0" Soldier Beam	215.00 LB
F38902	8'-0" Soldier Beam	150.00 LB
F38901	4'-0" Soldier Beam	85.00 LB
F38917	3'-0" Soldier Beam	68.00 LB
F38903	2'-0" Soldier Beam	52.00 LB
F38900	1'-6" Soldier Beam	45.00 LB

## SOLDIER HARDWARE

Product Code	Description	Weight
F40272	BCT Adjustable Jack	13.09 LB
F38919	Soldier 45° Bracket	27.20 LB
F38914	Soldier Attachment Angle MF	4.10 LB
F38911	Soldier Attachment Angle VF	3.20 LB
F38913	Soldier Guide Angle/Tie Angle	2.17 LB
F38918	Soldier HD Jack	28.00 LB
F65495	Hitch Pin w/Handle 1" dia x 5-5/8"	1.60 LB
F38910	Soldier Jack Bracket	33.00 LB
F38928	Soldier Lap Splice Plate	13.00 LB
F38916	Soldier One-Sided Bracket	54.53 LB
F38907	Soldier Pivot Bracket Assembly	35.00 LB
F47975	Soldier Pivot End Bracket	19.84 LB
F38924	Soldier Pocket Former	4.18 LB
F38921	Soldier Riser Bracket Assembly	18.00 LB
F38915	Soldier Shear Plate	19.28 LB
F47951	Soldier Shim Plate	10.97 LB
F38908	Soldier Strut Jack Assembly	51.50 LB
F38905	Soldier Tie Washer Plate	17.00 LB
F38922	Soldier Toggle Lock	49.00 LB
F38923	Soldier Toggle Lock Support	44.00 LB
F38920	Soldier Wheel Adapter/Spacer	17.00 LB
F33223	Versiform Bearing Wedge	31.58 LB
F32194	3/4" x 4" Speed Bolt	0.65 LB
F32195	3/4" x 3" Speed Bolt	0.60 LB
F32191	3/4" x 2" Speed Bolt	0.36 LB
F32193	3/4" Speed Nut	0.18 LB
F37610	3/16" Hairpin	0.04 LB

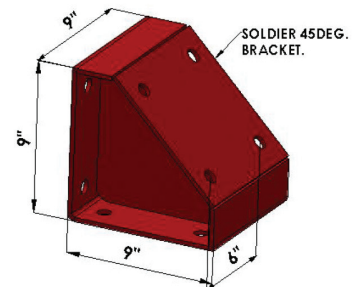
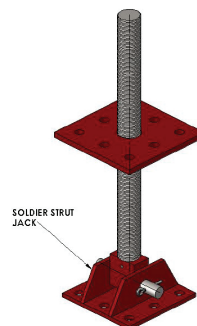
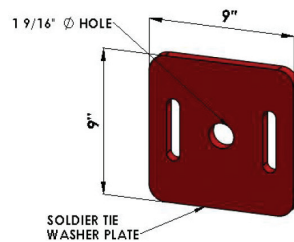
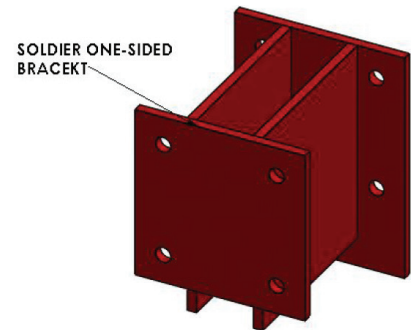
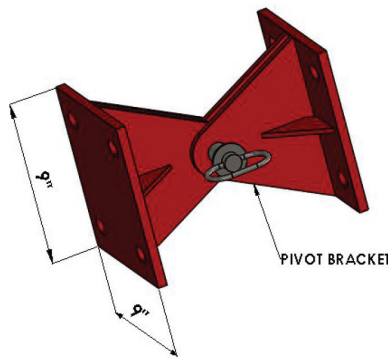



The strength of the Symons Soldier modules in this one-sided forming application allowed the contractor to eliminate the need for ties.



The contractor was able to rent and return the form liner they needed because they did not have to drill holes for ties.

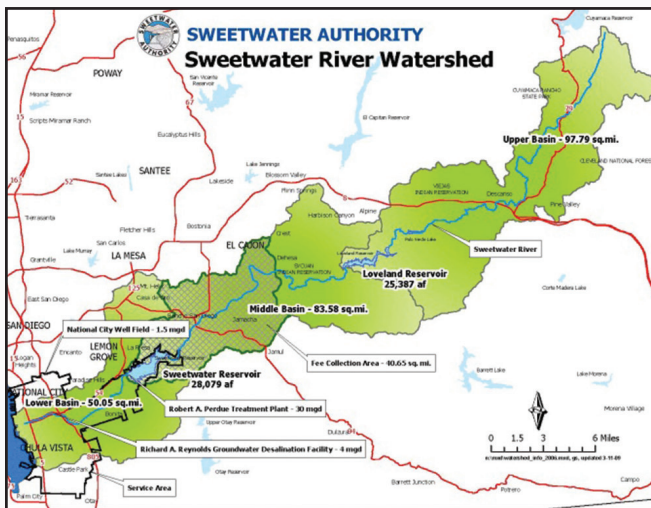

## Soldier Stands Its Ground

The Sweetwater Urban Runoff Control System, located in San Diego County, was designed to collect storm drain water and empty it into retention ponds near the Sweetwater Reservoir. The primary conduit for the system is a 48" diameter pipe which needed to be encased in concrete for 280' of it's length. PCL Civil Contractors was facing several challenges when planning this section.

The schedule allowed only 45 days to complete the pipe encasement, so Project Manager Jim Lumm knew he needed a plan to handle this short time frame.

The first lift, which formed the platform that the pipe rested on, varied in height from 3' to 10'. The second lift was 6' high and required the use of a heavily textured rock formliner. Since PCL had decided to rent the formliner, they did not want to put any tie holes through the material. Questions about rock face stability opposite the formwork, plus the time and labor to grout the ties and patch holes, made this option unacceptable.

Symons by Dayton Superior proposed a plan to Project Engineer Bo Boulier. The contractor could use Steel-Ply set horizontally and reinforced by Symons Soldier Beams. Combinations of Soldier lengths were used in 12' modules to reach the minimum and maximum heights necessary. Instead of a set of anchors for each pour, Technical Assistance designed the system to use one set of anchors for both lifts, minimizing the material and labor costs.

The contractor was impressed with the strength and adaptability of the system. The Project Manager reported that the labor-saving system helped his crew complete this section ahead of schedule.

# SHORES AND SUPPORTS

## Soldiers Rise to the Occasion

When Frank McCracken, the contractor representing Akron School District R-1, approached Symons by Dayton Superior seeking advice about forming the risers for a high school stadium, he stated that he preferred a system that is assembled once and moved for multiple reuses.

Symons suggested a combination of Symons Soldiers with Max-A-Form Rigid Screw Jacks for the framework of the system, and Steel-Ply for the riser forms. He explained that a 20' stretch of all ten 12" tall, 2'-8" wide risers could be formed in one operation and then moved to the next pour.

Once the idea was approved, the engineering layout began. A grid of vertical and horizontal Soldier Beams were stiffened with diagonal Soldier Beams. The diagonal members were supported with Max-A-Form Rigid Jacks inserted into Swivel Screw Jack brackets, and the whole assembly was supported by strut jacks during pouring operations.

In addition to creating a grid to hold the formwork, engineers designed a unique way to move the forms from one pour to the next. Horizontal Soldier Beams were bolted to vertical members at the top and bottom of the frame and 10" rigid wheels were attached to the horizontal beams. When the forms were stripped by raising the strut jacks, a forklift lifted each end of the frame, an W8" x 10" steel beam was placed on its side under the rigid wheels, and the whole assembly was rolled to the next location.

The contractor was very pleased with how quickly the forming system assembled and how easily it moved from one location to another.



A grid of Symons Soldiers and Max-A-Form components supported the Steel-Ply forms for the high school stadium project.



The 20' wide system was designed to roll from one location to another for multiple reuses.



## Symons Had All the Answers!

Grant Park is a 327 unit residential project located in downtown Minneapolis. The project was built on a fast-track, design-build basis with Opus Northwest as Design-Builder. Opus Architects & Engineers, and Humphreys & Partners Architects provided Architectural Services.

Opus was already familiar with the advantages of using the Garage Beam System (GBS) from previous projects, so they were confident in choosing this system again. They knew that the detailed design and structural plans provided by Symons simplify formwork and reduce related concrete construction costs.

Aluminum Beam Gangs were used to form the foundation walls and shear walls of the tower and parking ramp. Sizes ranged from 8' wide x 12' high to 24' wide x 18' high to accommodate the different wall heights and section widths throughout the project. Steel-Ply forms were used to accommodate areas with unique forming challenges, such as penetrations.

Steel-Ply was also used to form the columns in the tower and for the city homes that surround the ramp. The foundation walls for the residential units were cut up with lots of corners, and handset Steel-Ply really worked great in this situation.

Opus knew that they could count on the forming systems and detailed plans from Symons, so we were the only form supplier on site for the whole job!



GBS has beam form assemblies, leg supports, column and capital forms, and deck panels.



The tower foundation and shear walls utilized Aluminum Beam Gangs reconfigured to the various dimensions required.



**ENGINEERING SERVICES**

**CONCRETE RESULTS DELIVERED**

We offer a rare balance of personal expertise and modern technologies, to deliver precision performance throughout the design, build and maintenance stages of your product.

Our experts bring professional design and meticulous detail to your project:

- PE Stamps
- Formwork Design
- Detailed Drawings
- Structural Engineering Support

We deliver the reliability you want and the results you demand:  
**888-977-9600.**

**DAYTON SUPERIOR**





**SYMONS**<sup>®</sup>

BY DAYTON SUPERIOR

1125 Byers Road  
Miamisburg, OH 45342  
937-866-0711  
888-977-9600  
[www.SYMONS.com](http://www.SYMONS.com)

**THE  
POWER  
OF RED**<sup>™</sup>

WF\_1142050 / SYM ALL  
REV. 04/26

Copyright © 2026 Dayton Superior Corporation, All Rights Reserved.