



**THE
POWER
OF RED™**

**DECKFAST™
SHORING SYSTEM**

**CONCRETE
CONSTRUCTION
SOLUTIONS**

BROCHURE



SYMONS®
BY DAYTON SUPERIOR

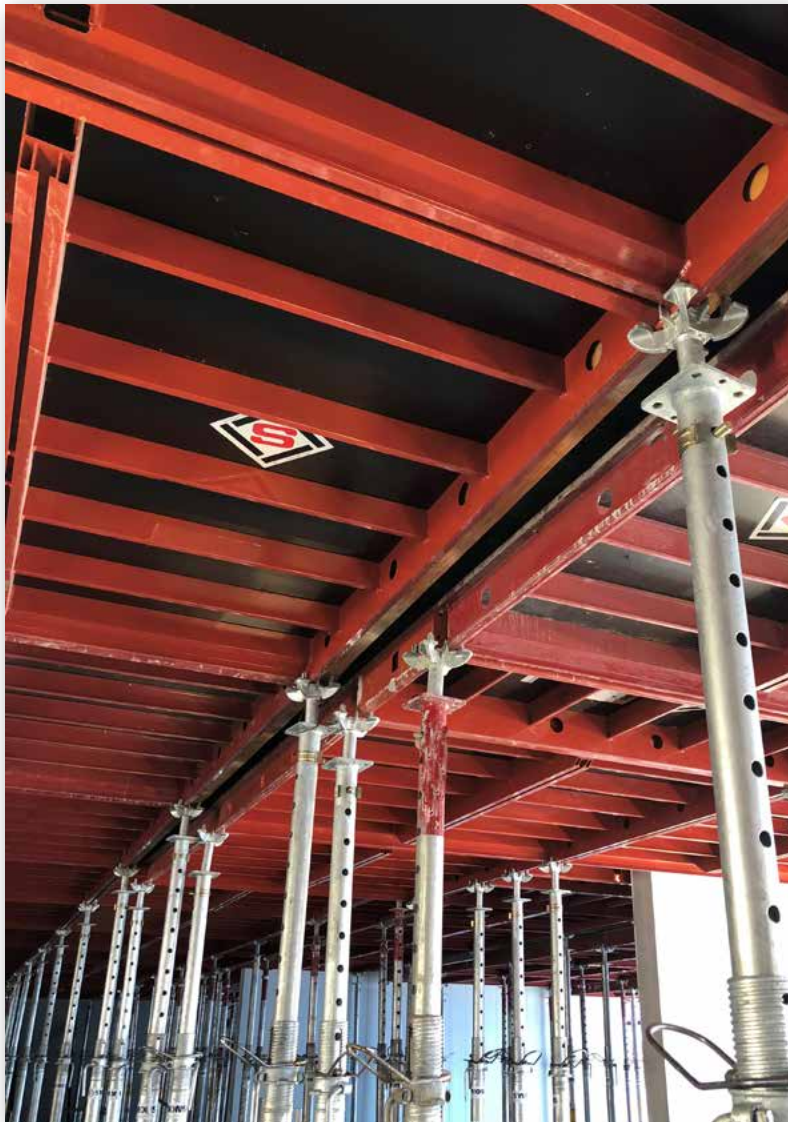

The two-component slab form system!

DeckFast is as simple and quick as erecting two components to provide a ready-to-pour slab surface!

Super-sized panels yield high productivity

The DeckFast panel productivity is increased further with the large 180cm x 180cm panel (nominal 6' x 6'). This large panel accelerates set-up speed and overall labor savings. The aluminum frame and high capacity galvanized post shore with drop-pin, yield amazing results for on-site productivity.

Lower plywood costs

Obtain an excellent finish which nearly eliminates post-pour cosmetic costs. Budgeted plywood costs remain in the pocket of the contractor.

Fewer accessories limit in-fill expenses

The system features few, but functional, accessories to eliminate those costly in-fill areas. Adjustable panels have built-in nailers for odd incremental fills. Supported nailer strips and head support accessories are used for in-fill around columns and unusual fill areas. Reversible triangular panels allow for radius forming. Symons can even provide an in-slab beam bracket which supports your beam bottom and sides. Accessories make slab forming even quicker and more efficient.

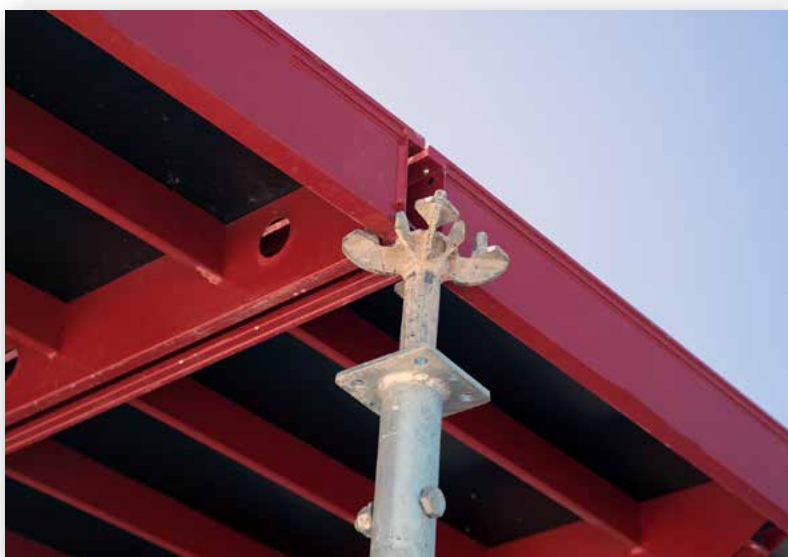

Easier preplanning and design

DeckFast is capable of heights up to 18'-11" and a slab depth of 22"*. Imagine no "stacking" shore frames and slab depths up to 22"* or the engineering required to position frames, stringers and joists.

Reduced labor and increased productivity

The system excels beyond the productivity of conventional shore frame systems. It allows the erection or dismantling of an average of about 1,000 ft² per person per day for most flat slab conditions! Compare this to an optimistic 450 ft² per person per day with conventional shoring systems.

Less re-shoring

When 100% re-shoring is required, you'll benefit from a spacious 180 cm x 180 cm panel (6' x 6' nom.) spacing with the DeckFast system. The same shore that supports the panel becomes the re-shore.

Less maintenance and cleaning

The precision-manufactured panels fit so tightly together that only minimal amounts of slurry may adhere to the narrow top edge of the panels. Note the special edge profile protecting the plywood and frame.

Modular flexibility

DeckFast is most commonly utilized to produce a flat-bottomed deck, but individual shore height can be adjusted slightly to produce vaulted ceilings. **Note:** Consult Technical Services for this application.

Safety and stability

Guardrail Bracket	May be installed along edges or sides of the panels prior to lifting panel into position.
Guardrail Bearing	Connects guardrails to sides and front of DeckFast deck panels.
Guardrail Post	A safety post designed to support lumber guardrails.
Tripods	Provide easy set-up and extra stability during erection process.
Cantilever Support System	Safely supports the system in an extended slab/walkway condition. This system, comprised of the Bracing Frame 180 and Cantilever Frame with Tie Down Assembly, allows the system to be cantilevered a maximum of 29" with a 25" maximum walkway.

* Maximum depth using 60 x 180 panels.

Get more information online on the [Symons DeckFast Product Page:](#)

- Shoring Safety Rules Poster
- DeckFast™ Safety Poster
- DeckFast™ Application Guide





Set the frame

Workers position the 180 cm x 180 cm panel DeckFast panel onto the bearing from below. The almost 35ft² panel with HDO plywood weighs only about 100 lbs and is easily set by two workers.

Swing into place

The adjustable Erection Rod lifts the panel into a horizontal position and serves as a temporary support awaiting placement of the shore post.

Shore it

Position the pre-lengthened shore(s) to complete the erection process.

It's just that simple ... set, swing and shore. This repetitive yet elementary erection process yields productivity well beyond conventional handset shoring systems.



Stripping is as easy as reversing the 3-step process

Lower the shore with the shore's quick release device, turn the collar down, support and swing the panel downward to the disassembly position. Slightly lift and remove the panel for its next use.

Simply the Best...

In addition to supporting the panels, the post shores have the industry's quick release stripping mechanism which can save up to 50% of your labor cost when compared to other shores.

Two types of post shores are available. The 350 extends from 6'-8" to 11'-5" and weighs 46.5 lbs. The 550 extends from 9'-10" to 18'-0" and weighs 74.2 lbs.

Our quality post shores are hot-dipped galvanized, including the welds and threads, to prevent interior or exterior rust. In fact, all of the steel accessories are hot-dipped galvanized to ensure their longevity.

Watch the YouTube video to see it for yourself: [eM1_QjvWqcE&t=2s](https://www.youtube.com/watch?v=eM1_QjvWqcE&t=2s).

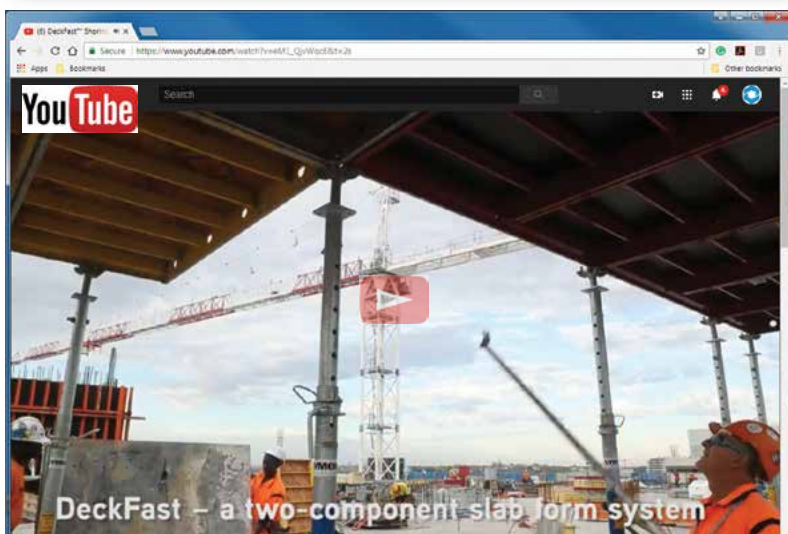

Drop-pin, under-load stripping mechanism

Whether the post shore is supporting DeckFast, re-shoring or a conventional deck shoring system, its drop-pin can save you up to 50% of the dismantling labor.

How it works

The pin is placed in the load position when the shore is set. Following the pour, the stripping pin is struck with a hammer, which causes the shore's upper staff to lower approximately $\frac{1}{8}$ ". (The hardened pin is designed for this purpose.) The weight of the concrete pressure has now been relieved. The handle screws easily downward to facilitate the stripping function.

The single hammer blow to the end of the hardened stripping pin easily facilitates what is commonly the most difficult portion of the stripping process.

- You don't need to take the time for the consuming and costly efforts required in conventional shoring.
- You don't need a "cheater" bar (utilized to improve leverage to break the load pressure on other systems).
- You don't need to strike the metal casting collar or handle with a hammer until released. (This action can crack the casting or break the handle.)
- You don't need to strike the bottom of the shore with a sledge or large hammer until the shore falls. (This action can dent the lower outer tube so that the shore can not telescope.)

Our post shore eliminates the intensive labor and costly repairs typically associated with stripping competitive systems.

Because of its hot-dipped galvanized steel construction, high capacity and unique drop-pin stripping mechanism (while under load), we believe this shore to be the best in the industry.

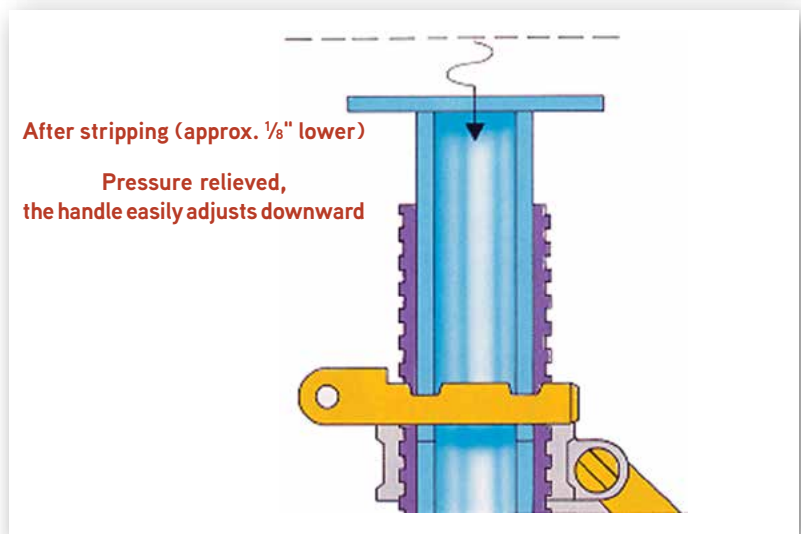
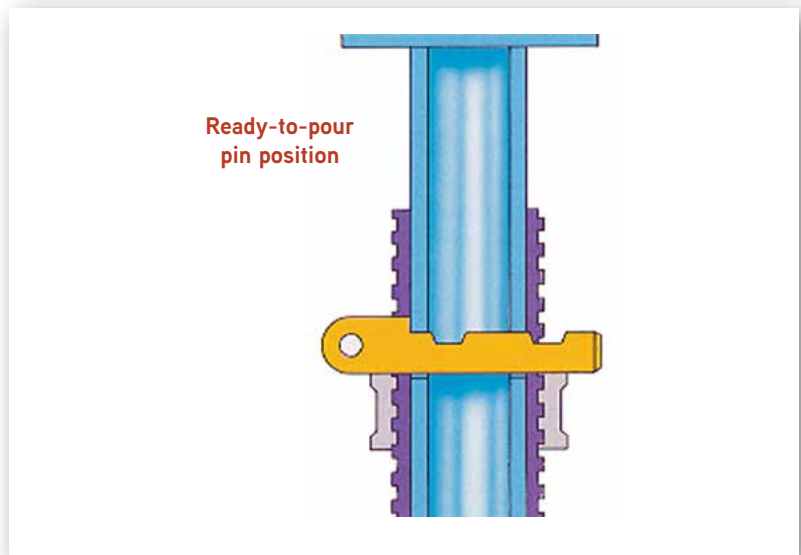
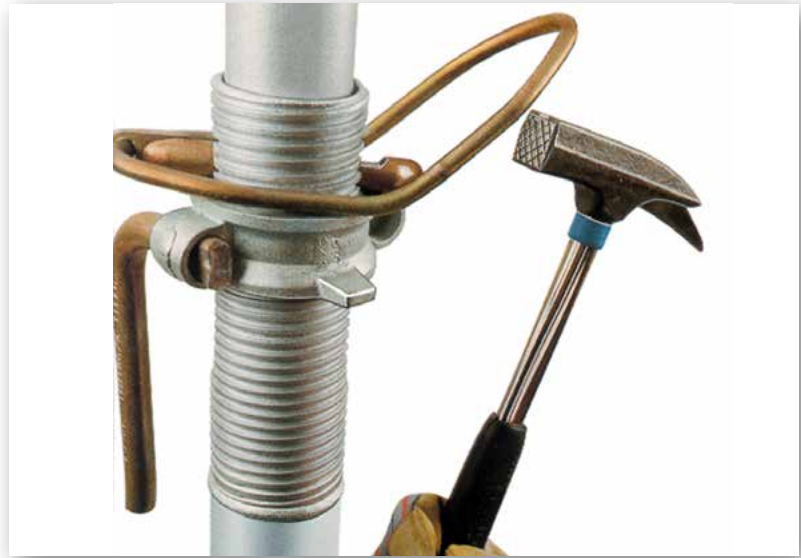

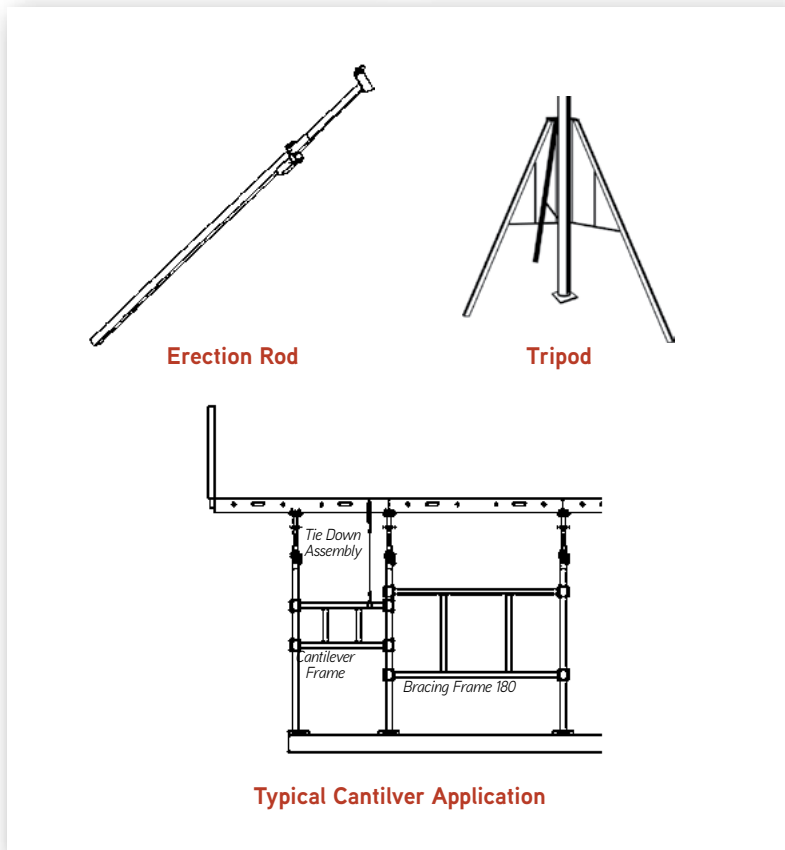
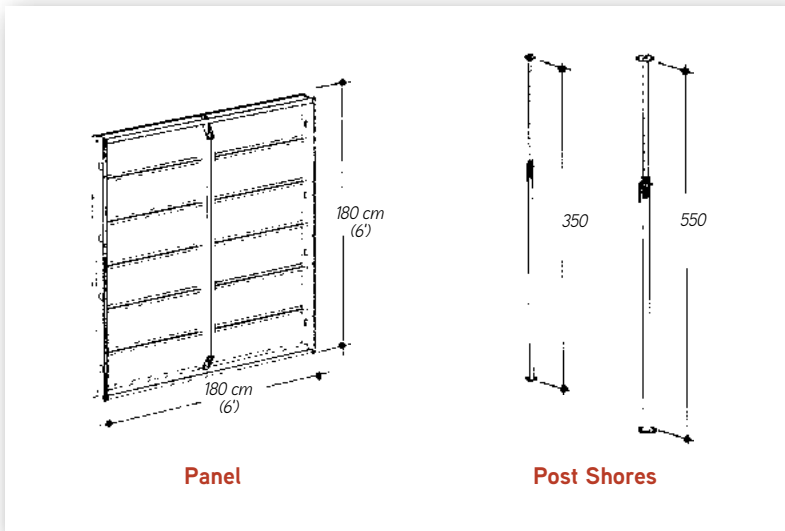

Basic Equipment

The number of components required for the DeckFast™ slab forming system is minimal.

180cm x 180cm Panel (approx. 6' x 6')	Square aluminum frame with 5-ply bonded plywood. The plywood edge is sealed and protected by the aluminum frame.
180cm x 90cm Panel (approx. 6' x 3')	Higher capacity for high load applications.
Bearing Heads*	Mounted into the tubular steel shores, the cams firmly engage four corners of the panels.
Edge Support Heads*	Support the long sides of the panels along an existing wall.
Post Shores	The 350 has a capacity of 4,631 lbs at 11'-11" to 7,733 lbs at 6'-8" with a 2.5:1 safety factor. The 550 has a capacity of 3,260 lbs at 18'-0" to 11,240 lbs at 9'-10" with a 2.5:1 safety factor.

Erection Aids

A number of components assist with erecting the DeckFast system or for handling special forming situations.

Erection Rod	The lightweight telescopic tube can be adjusted for slab heights up to 18'-11" with Extension Rod.
Tripods	Erection aids during the initial setting of the system.
Bracing Frame 180	Can be used to space, support, and aid in the erection of the 180cm x 180cm panel. Can also be used in conjunction with the Cantilever Frame and Tie Down Assembly to allow cantilever applications.
Cantilever Frame and Tie Down Assembly	The DeckFast system can be cantilevered up to a maximum of 29", providing a walkway of 26".

Versatility

In-fill areas can easily be formed with the DeckFast™ slab forming system using just a few components. Even complicated areas and curves can be accommodated. Corner Panels and Corner Frames are placed without additional shoring.



<p>Supplementary Panel 90 x 45/60/75/90 and 180 x 45/60/75/90</p>	<p>Panels 90 cm or 180 cm (35³/₈" or 70⁷/₈"") are available in widths of 45cm to 75cm (17³/₄" to 29¹/₂"") at increments of 15cm (5⁷/₈"").</p>
<p>Adjustment Panel 90 x 45-90</p>	<p>The sliding Adjustment Panel 90/180 can be adjusted from 45cm to 90cm (17³/₄" to 35³/₈""). The panel is equipped with built-in nailers and can be utilized with all other panel sizes.</p>
<p>90/90 Corner Panel</p>	<p>Triangular aluminum frame with attached multi-ply panel, 21mm (1³/₁₆"") thick.</p>
<p>180/90 Corner Frame</p>	<p>The aluminum frame is supplied without plywood so the frame is reversible.</p>
<p>180/90 Corner Sheet</p>	<p>The plywood for the Corner Frame, is designed for use on either side of the frame. Two edges of the 21mm (1³/₁₆"") thick multi-ply sheet are protected by unique edge profiles.</p>
<p>Adjustment Beams 90 cm or 180 cm</p>	<p>Aluminum profile with built-in nailer strips for forming in-fill areas.</p>
<p>Transverse Beam</p>	<p>Similar to Adjustment Beam, but running transversely. Steel profile with a wooden nailer strip for plywood attachment. Use Adjustment and Transverse Beams together to fill in around columns.</p>
<p>Head Support Shoe</p>	<p>Top-mounted component for Bearing Heads or Edge Support Heads. They support 4x4 lumber and plywood to equal the DeckFast deck height.</p>

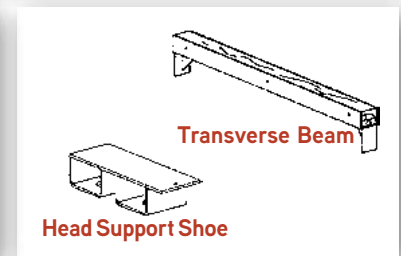
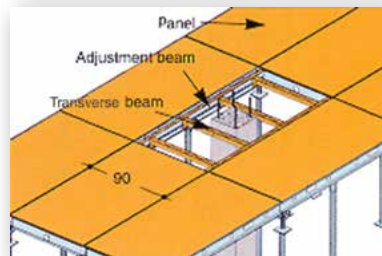
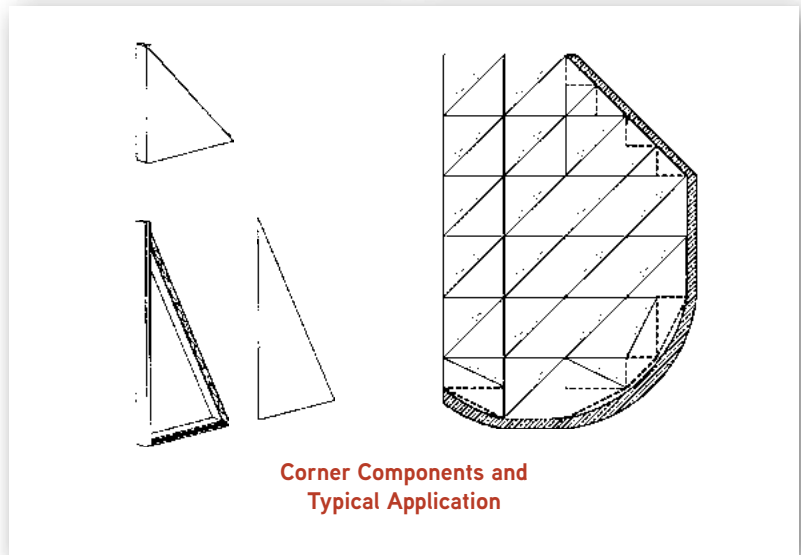



SYMONS[®]

BY DAYTON SUPERIOR

1125 Byers Road
Miamisburg, OH 45342
937-866-0711
888-977-9600
WWW.SYMONS.COM

THE POWER OF RED™

SYM117
03/19

Copyright © 2016 Dayton Superior Corporation, All Rights Reserved.