



# THE POWER OF RED™

**ALUMINUM  
BEAM GANG**

**CONCRETE  
FORMING  
SYSTEM**

**BROCHURE**



**SYMONS®**  
BY DAYTON SUPERIOR



Symons Aluminum Beam Gang Forming System offers design-optimized aluminum beams with an extremely high strength-to-weight ratio. The unique beam attachment clips, sturdy aluminum beams and steel walers combine to create the most rigid, compact, and lightweight gang form system on the market.

The Aluminum Beam Gang Forming System can be used for virtually any concrete forming application. Unlike competitive aluminum gang forming products that may suffice for simple straight walls, you can form corners, pilasters, core walls, curved walls, and other configurations easily with this system.

Symons also has a unique Transition Bracket to permit quick attachment to other Symons concrete forming systems. The Transition Bracket allows you to switch over to Versiform® or Steel-Ply® components to fit your forming needs.

### System Flexibility

Water spacings and tie locations can be adapted to specific forming requirements for maximum Aluminum Beam Gang flexibility on almost any project.

Tie patterns are easily accommodated with two different tie capacities. Less time is required because ties can be conveniently placed. Tie and waler hardware, walkway brackets and wall braces are standard components, available for rent or purchase.

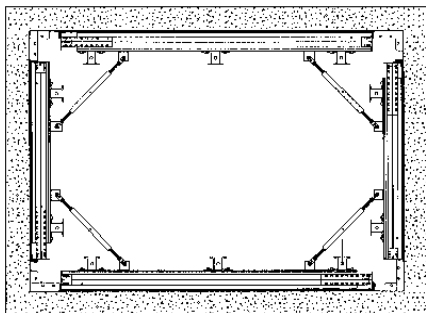

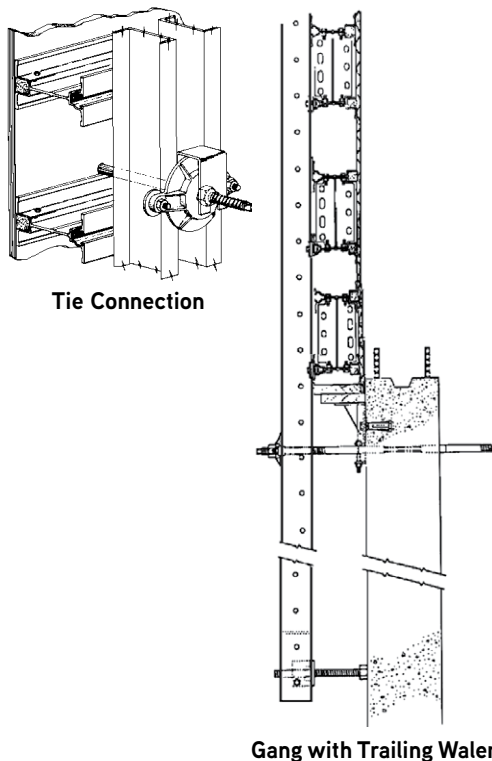

The Aluminum Beam Gang Forming System is easy to assemble, position and align. The lightweight aluminum beam gang maximizes the square footage of forming contact area.

The advantages of the Aluminum Beam Gang Forming System are:

- Users of job-built, lumber gang forms find this system lighter, with higher reuse and simple alignment.
- New 3/4" plywood with the Aluminum Beam Gang provides an exceptional concrete finish for architects, engineers and owners.
- Lightweight Aluminum Beam minimizes total gang form weight and reduces crane size requirements.
- Aluminum Beam or Joist Extension Brackets can be used to build virtually any gang size dimension.
- Steel Walers provide maximum tie spacing for productive concrete forming and can be used when lifting the gang.
- Trailing Walers with plumbing screws and Walkway Brackets can be added after the first lift, eliminating repositioning Walers.
- Adapts to other Symons forming systems to reduce costly job-built details.



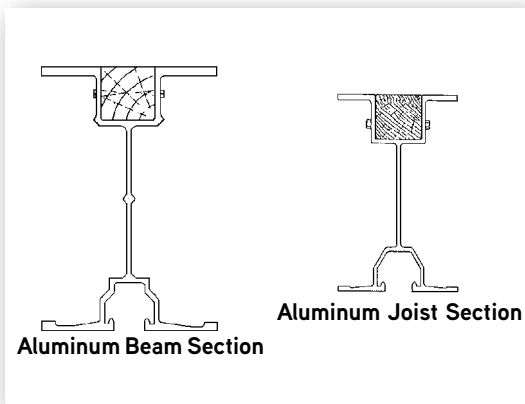

### Aluminum Beams and Joists

The Aluminum Beam has a 7¼" section height with a 2x2 nailing strip for secure plywood attachment. This section height is compatible with 2x8 lumber used for filler sections. Beam lengths range from 4' to 28' in even 2' increments, size indicated on each beam. A 5" wide base flange provides stability, and a special longitudinal web provides exceptional strength and rigidity. Although it weighs only 4.6lb/ft, the Aluminum Beam supports long spans with less deflection than job-built lumber gangs.

The Aluminum Joist has a section height of 6½" and a flange width of 4". At 3.5 lbs/ft, it offers a lighter weight alternative to Aluminum Beams. They are available in lengths of 5' to 21' in 2' increments.



### Attachment Clips

A unique Beam Attachment Clip makes securing Aluminum Beams or Joists to Walers quick and easy. The friction connection provides secure assembly, but is simple to modify for various forming conditions.

The square nut is simply inserted into the channel of the aluminum component, and the nut tightens the assembly in place.

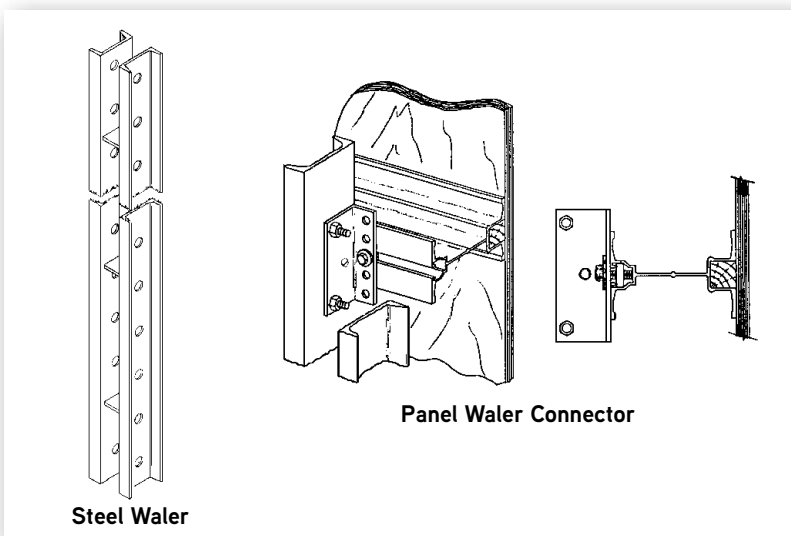
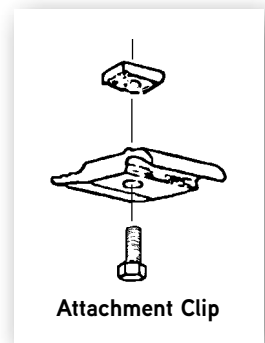

### Steel Walers

Two Waler sizes, 5" and 8", provide strong-back and tie placement support for the Aluminum Beam Gang Forming System. Steel Walers are less susceptible to damage and require fewer ties.

Waler lengths range from 4' to 16' in even 2' increments. Splice channels are available to extend Waler length with full moment strength.

### Panel Waler Connectors

Panel Waler Connectors attach the Aluminum Beam Gang to the Walers. Waler Lifting Sleeves, used for properly lifting gangs, have a safe load rating of 2,000 lbs.

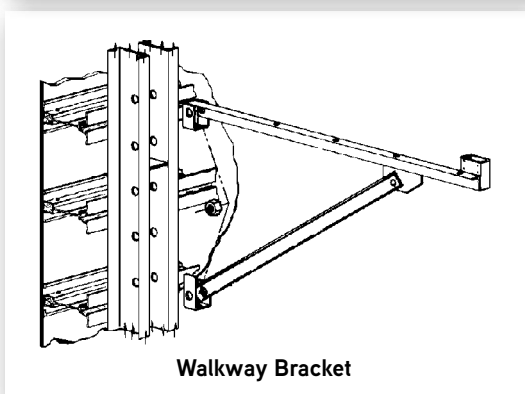

### Walkway Brackets

Platforms supported by Walkway Brackets provide safe access to gangs when pouring concrete. These invaluable platforms also can be used when installing or stripping ties and related hardware.

### System Compatibility

Steel-Ply or Versiform panels bolt to a Transition Bracket that is bolted to the Aluminum Beam Gang Form. Plywood facing continues the finish provided by the plywood faced gang form.

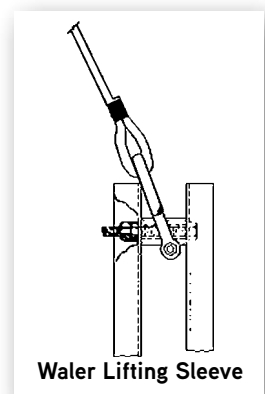

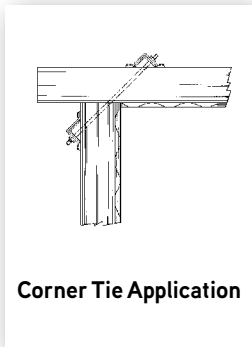

### Outside Corners

When forming outside corners with Aluminum Beam Gang Forms, the distance between a corner and the end Walers on adjoining gangs establishes the tie method.

Two corner tie methods are available using Corner Tie Brackets to resist the lateral loading of the concrete.

### Inside Corners

Standard Versiform corners are attached to Aluminum Beam Gang with a Transition Bracket and an Extension Plate. The combination provides the inside corner with proper alignment.

### Transition Brackets

The Transition Bracket extends the forming capabilities of the Aluminum Gang Forming System. This bracket permits the system to be used with Versiform and Steel-Ply components to form bulkheads, pilasters, corners, core walls or other project details.

### Extension Plates

Extension Plates attach to the Transition Bracket and allow 2<sup>3</sup>/<sub>4</sub>" to 11" extension beyond the end of the Aluminum Beam or Joist.

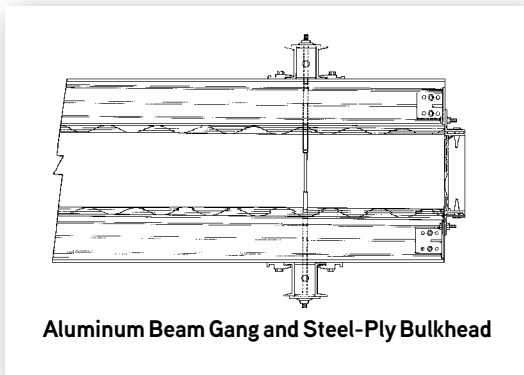
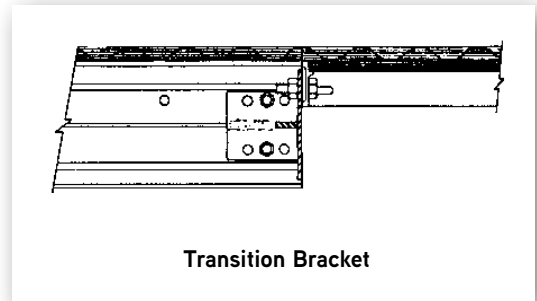

### Bulkheads

A Steel-Ply filler is attached by Wedge Bolts to Transition Corners. Transition Corners are bolted to Transition Brackets which are fastened to the Aluminum Beam Gang Form to create bulkheads.



### Pilasters

Pilaster details between Aluminum Beam Gangs can be formed with Steel-Ply components. The Pilaster Form and Steel-Ply or Versiform transition provide adjustable pilaster sizes, while linking gangs around this complex detail.

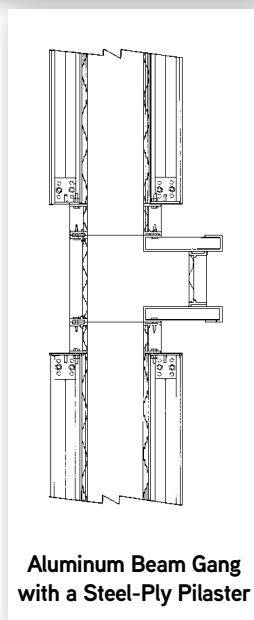

When you compare the Aluminum Beam Gang Forming System with other systems, you'll find that Symons offers a complete line of components and accessories to handle virtually any forming situation.

The Aluminum Beam Gang Forming System provides solutions for bulkheads, pilasters, corners, batter walls, core walls, curved walls, multiple lifts, top ties and walkways. There are no unsolved details to be concerned with, and no makeshift field solutions are necessary.

Contour-threaded hardware is available for use with the Aluminum Beam Gang Form System to eliminate concrete buildup and special transitions to other forming systems. Like Symons other forming system accessories, these components are designed to eliminate mishaps, reduce waste and maximize forming productivity.



**SYMONS**<sup>®</sup>

BY DAYTON SUPERIOR

1125 Byers Road  
Miamisburg, OH 45342  
937-866-0711  
888-977-9600  
[WWW.SYMONS.COM](http://WWW.SYMONS.COM)

**THE  
POWER  
OF RED™**

SYM99487  
10/17

Copyright © 2017 Dayton Superior Corporation, All Rights Reserved.