



**MAX-A-FORM® STS**

CONCRETE  
CONSTRUCTION  
SOLUTIONS

**APPLICATION GUIDE**

**THE  
POWER  
OF RED™**



**SYMONS®**  
BY DAYTON SUPERIOR

## A WORD ABOUT SAFETY

High productivity depends on safety; even a minor accident causes job delays and inefficiency, which run up costs. That's why Symons by Dayton Superior, in the design of its systems and products, makes the safety of those people who will be working with and near the equipment one of its primary concerns. Every product is designed with safety in mind, and is tested to be certain that it will perform as intended with appropriate safety allowances. Factory-built systems such as these provide predictable strength, minimizing the uncertainty that often surrounds "hand-made," "job-shop" and "job-built" equipment.

As a result, Symons by Dayton Superior products are your best assurance of a safe operation when used properly. To insure proper use, we have published this application guide. We recommend that all construction personnel who will be involved, directly or indirectly, with the use of this product be familiar with the contents of this guide.

As a concerned participant in the construction industry, Symons by Dayton Superior also recommends that regular safety meetings be held prior to starting the forming operation, and regularly throughout the concrete placement, form stripping and erection operations. Symons by Dayton Superior personnel will be happy to assist in these meetings with discussion of safe use of the equipment, slide presentations and other formal safety information provided by such organizations as the Scaffolding, Shoring and Forming Institute.

In addition to the above meetings, all persons involved with the construction should be familiar and in compliance with applicable governmental regulations, codes and ordinances, as well as the industry safety standards developed and published by each of the following:

- American Concrete Institute
- American National Standards Institute
- The Occupational Safety and Health Administration
- The Scaffolding, Shoring and Forming Institute

Because field conditions vary and are beyond the knowledge and control of Symons by Dayton Superior, safe and proper use of this product is the responsibility of the user.

## TABLE OF CONTENTS

<b>I. Introduction.....</b>	<b>1</b>
<b>II. Basic Elements.....</b>	<b>1</b>
A. Panels .....	1
B. Bolts and Connections .....	2
C. Wall Ties .....	3
D. Top Tie/Lift Bracket .....	5
E. Ladder .....	6
<b>III. Gang Assembly.....</b>	<b>7</b>
A. Accessory Installation.....	8
B. Gang Care and Placement.....	13
C. Accessories and Applications.....	14
D. Columns.....	16
E. Tie Obstructions.....	18
<b>IV. Max-A-Form STS Self-Spanning Applications</b>	<b>19</b>
A. Assembly .....	19
B. Bottom Ties .....	21
C. Soffit Support .....	21
D. Stability Beams.....	22
E. Support Devices.....	22
F. Spreader Beams.....	28
G. Thru Bolts and Imbeds.....	28
H. Installation Sequence:Imbeds and Jacks	29
I. Placing Gangs.....	29
J. Stripping .....	30
K. Hammerhead Stripping.....	32
L. Hinged Soffit Stripping.....	33
<b>Index.....</b>	<b>35</b>

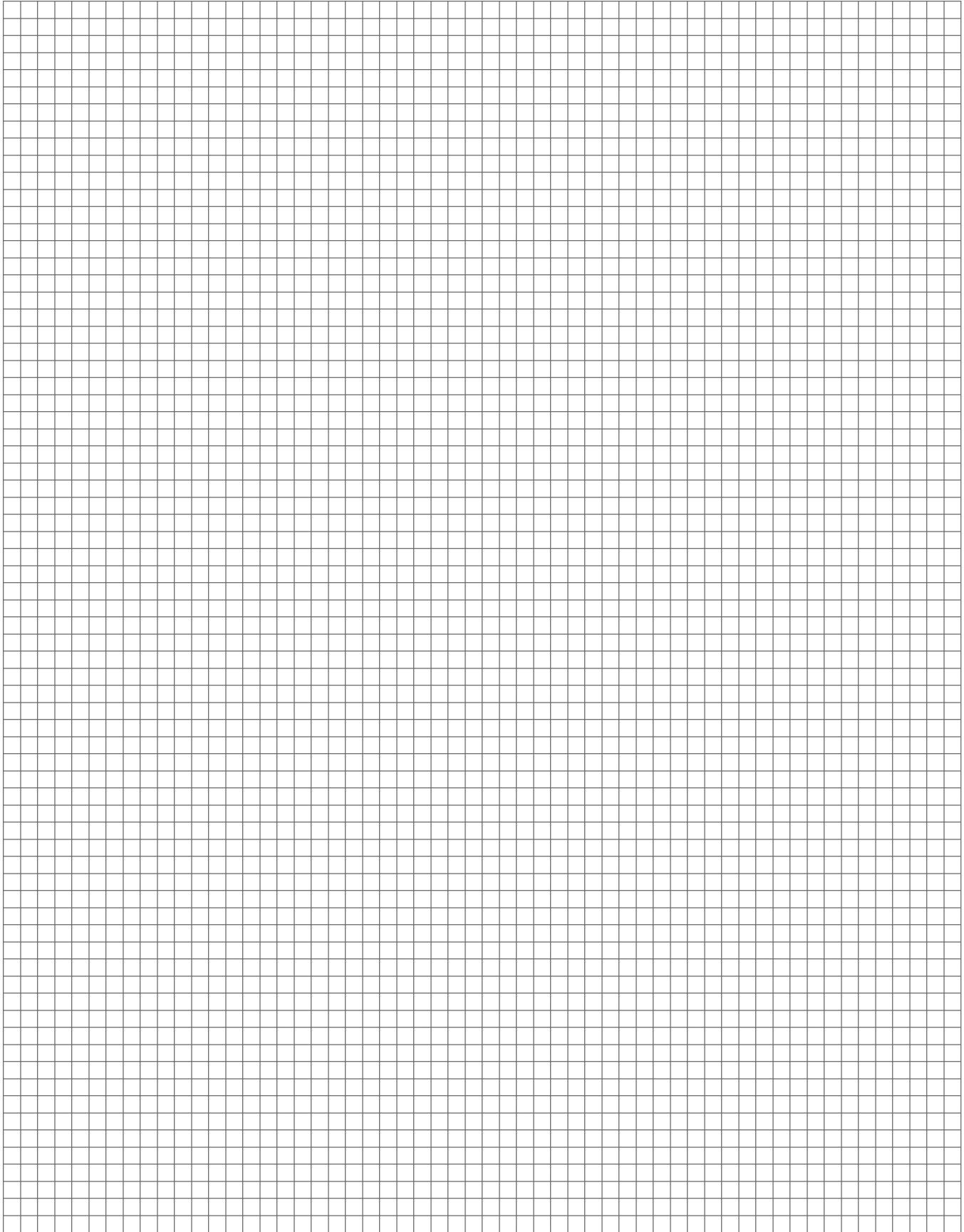

## I. INTRODUCTION

Max-A-Form® STS is a steel faced and steel framed modular forming system rated at a maximum of 2000 pounds per square foot (psf) of concrete pressure. The modular panels are available in a wide variety of sizes in order to make optimum sized gang forms. Crane handled Max-A-Form STS produces excellent concrete finishes in both wall forming and self-spanning applications.

Components and accessories used with Max-A-Form STS have been designed for safe and efficient forming operations. It is recommended that all construction personnel review and follow the applicable standards and practices established by the American Concrete Institute, the American National Standards Institute, the Occupational Safety and Health Administration, and the Scaffolding, Shoring and Forming Institute.

**Caution:** Components should be inspected regularly for damage. Damaged equipment must be replaced.

The procedures outlined in this Application Guide describe standard application procedures for the Max-A-Form STS Forming System. Since field conditions vary and are beyond the control of Dayton Superior Corporation, safe and proper use of the equipment is the responsibility of the user.

Sections I through III (One through Three) describe Max-A-Form STS and its applications in the continually supported mode. Self-spanning applications are presented in Section IV.

## II. BASIC ELEMENTS

### A. Panels

1. Max-A-Form STS is an all-steel modular forming system with a ¼" steel face plate and sections welded together. The precise tolerances and built-in strengths generate superior strength and a high quality concrete finish. The panels are designated by their width (the stiffener directions) and length.
2. Width: The panels are made in eleven standard widths: 2', 2'-6", 3', 3'-6", 4', 5', 6', 7', 8', 10', and 12'. 9' wide panels are also available. The 2' through 8' widths are designed for concrete pressures of 2000 pounds per square foot (psf), 9' wide panels are rated for 1,700 psf, 10' widths are rated at 1600 psf, and the 12' wide panels for 1300 psf. The 2' through 7' wide forms are 6 ½" thick, 8', 9', and 10' forms are 8 ½" thick, and the 12' wide forms are 10 9/16" thick.
3. Length: The Max-A-form STS panels come in five standard lengths: 1', 2', 4', 8', and 12'. In addition, 3', 5', 6', 7', 9', and 20' lengths can be produced. The 2'-6" and 3'-6" wide panels are only available in 1', 2', 4', and 8' lengths. Each length has its own tie location pattern illustrated below.

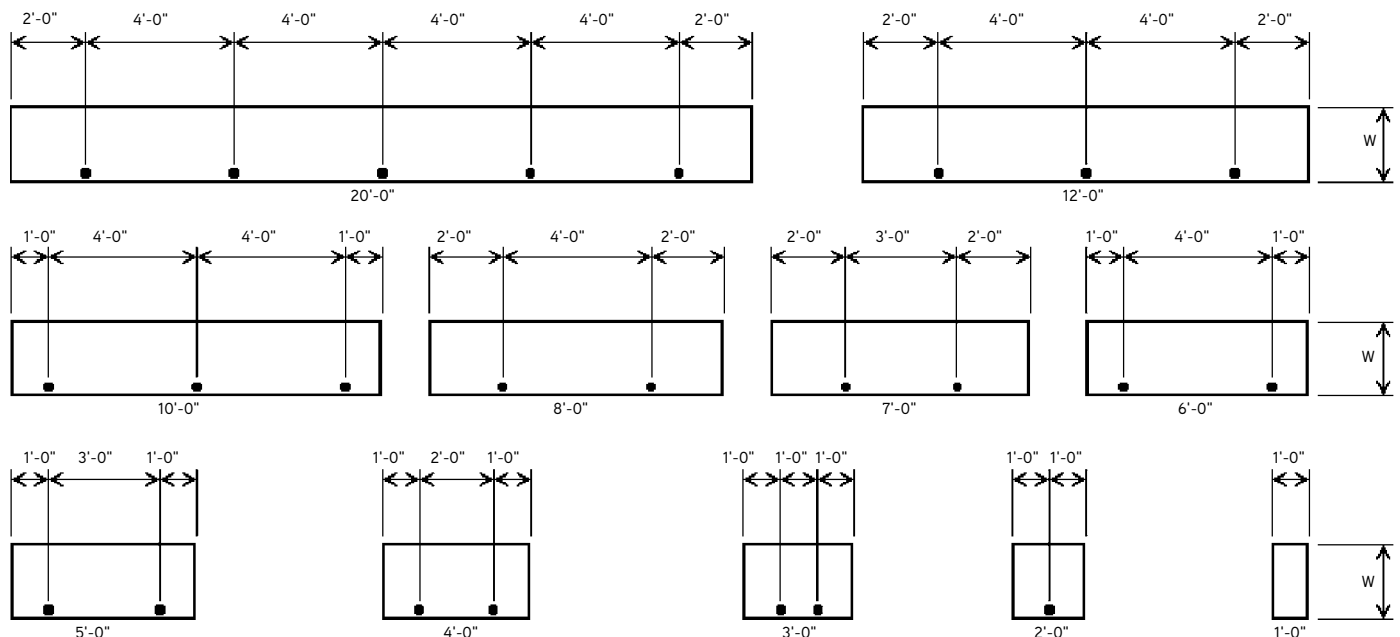

Tie Locations for Max-A-Form STS Panels



**B. Bolts and Connections**

1. Speed Bolts, 3/4" x 2", are used one foot on center at face side gauge line, inserted in the 13/16" x 1/4" slots around panel rails. For extra stiffness, additional speed bolts can be used on alternate gauge lines.
2. The Speed Bolts are high strength, A325 equivalents. They should be installed snug tight plus 1/3 additional turn.

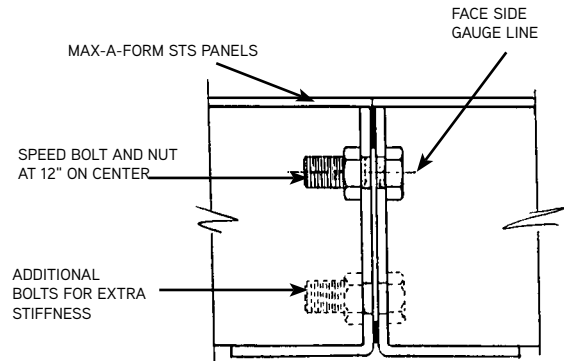

**Max-A-Form STS Panel-To-Panel Bolt Connection**

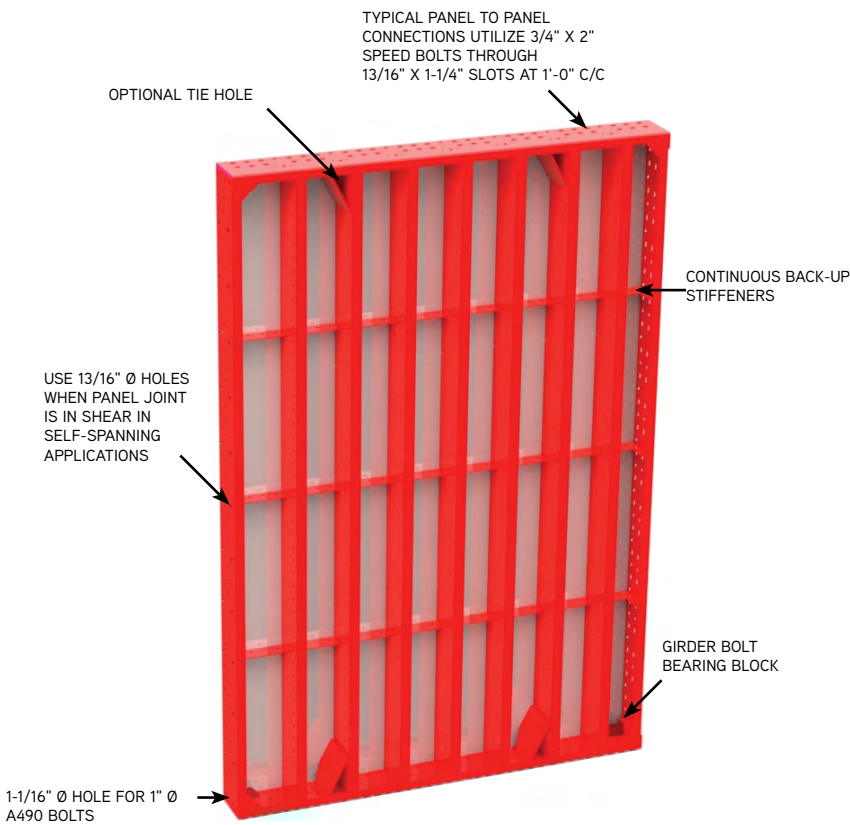

**Typical Max-A-Form STS Panel**

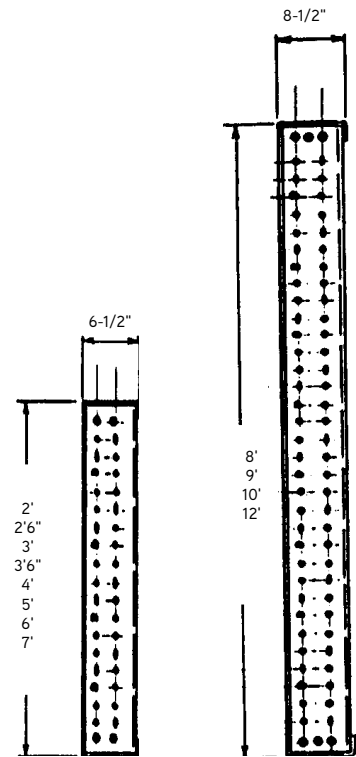

**Elevation**

**C. Wall Ties**

1. Wall ties must be in compliance with industry standards and safe practices established by the American Concrete Institute, The American National Standards Institute, The Occupational Safety and Health Administration, and The Scaffolding, Shoring and Forming Institute. Illustrations and capacities of Dayton Superior Taper Ties and She-Bolt Ties are given on the following page.
2. Dayton Superior project drawings indicate safe load capacities of Taper Ties and She-Bolt assemblies, when both outer unit and inner ties are supplied by Dayton Superior.
3. It is the contractor's responsibility to control concrete mix and placement procedures to assure that the maximum formwork design pressure is not exceeded.
4. The Super Taper Tie System has been specifically designed to handle the higher load requirements from Max-A-Form STS. This tie system is rated at a Safe Working Load of 64,000 lbs. The tie is tapered from 1¼" to 1½" and utilizes the same Swivel Wing Nut on both ends. This 100% reusable tie system is supplied with 2½" of threads per inch for rapid installation and stripping. The large tapered end comes with a square end to allow for wrench turning. The Swivel Wing Nut assembly is a heavy duty ribbed washer and nut which can accommodate batters up to 10° without the use of special washers. The entire assembly is electro galvanized finish per STM B633 SC1 Type II.

The reusable Super She-Bolt is designed specifically to handle the higher loads from the Max-A-Form STS System. This she-bolt features 1½" outside diameter with 32mm D/R outside thread and 26mm D/R inside thread and is rated at a Safe Working Load of 64,000 lbs. The she-bolt uses the same one-piece swivel wing nut accessory as Super Taper Tie. Two types of 26mm inside rods are available: rated at a Safe Working Load of 56,000 lbs and Safe Working Load of 64,000 lbs.

65K Taper Ties are tapered from 1¼" to 1", are rated at a Safe Working Load (SWL) of 32,500 lbs, and are supplied with 2½" threads per inch for rapid installation and stripping. Since the threads are the same diameter on either end, this taper tie system utilizes the same, one-piece swivel wing nut on either end. This assembly can handle battered walls up to 10 degrees without the use of special washers.

She-Bolt features a 1¼" outside diameter with 20mm D/R outside and inside threads, is rated at a SWL of 39,200 lbs, and uses the same one-piece swivel wing nuts accessory as 65K Taper Tie. B12A 20mm inside rods are rated at a SWL of 32,000 lbs.

**Super Taper Ties**

Product Code	Overall Length	Taper Length	Taper Size	Thread Size	SWL
145248	44"	25"	1¼" – 1½"	32mm	64,000 lbs.
145249	54"	35"	1¼" – 1½"	32mm	
145250	64"	45"	1¼" – 1½"	32mm	
145251	74"	55"	1¼" – 1½"	32mm	
145252	84"	65"	1¼" – 1½"	32mm	

**Swivel Plate**

Product Code	Description	Weight
145181	32mm Swivel Wing Nut with 5" x 7" Plate	7.09 lbs

**She-Bolt**

Product Code	Description	Outside Dia.	Weight
145402	32mm x 30" 128K She-Bolt with 26mm Inside Thread	1½"	10.5 lbs

**Inside Rod**

Product Code	Description	Weight
145429*	26mm x 5' D/R Thread Inside Rod 128 Kips Ultimate Load	2.67 lbs./ft.
145430	26mm x 12' D/R Thread Inside Rod 112 Kips Ultimate Load	2.67 lbs./ft.

\* SPECIAL ORDER ONLY

**65K Taper Ties**

Product Code	Overall Length	Taper Length	Taper Size	Thread Size	SWL
145555	37"	19.5"	1" to 1¼"	20 mm	32,500 lbs.
145556	47"	29.5"	1" to 1¼"	20 mm	
145557	57"	39.5"	1" to 1¼"	20 mm	
145558	67"	49.5"	1" to 1¼"	20 mm	

**Swivel Plate**

Product Code	Description	Weight	SWL
145554	20mm Swivel Wing Nut with 7" Round Plate	5.94 lbs.	32,500 lbs.

**She-Bolt**

Product Code	Description	Outside Dia.	Weight	SWL
123506	20mm x 24" D30A She-Bolt	1¼"	3.96 lbs.	39,200 lbs.

**Inside Rod**

Product Code	Description	Weight	SWL
121710	20mm x 20'-0" D/R Thread Inside Rod	1.60 lbs./ft.	32,000 lbs.

**Installation guidelines:**

- a. Coat the tapered portion of the tie with waterproof grease to facilitate taper tie removal
- b. Thread one piece swivel wing nut accessory on to large end of taper tie
- c. Install taper tie into the formwork when both panels are set
- d. Thread one piece swivel wing nut accessory on smaller end
- e. After concrete is poured and gains strength, remove the swivel wing nut on the smaller end
- f. Strike the taper tie on the small end and remove tie

**5. Tie Installation Precautions:**

- a. Be sure that the correct thread size Hex Nut, or Cast Contour Nut is mated to all Taper Tie or She-Bolt out-unit threads.
- b. Be sure that inner ties engage full thread depth in all she-bolts. Full thread engagement is noted as dimension "E" on illustration of she-bolt capacities and thread dimensions.
- c. Be sure that all ties using hex nuts with cast bearing washers, or flat washers, are installed perpendicular to both form faces. Hex nuts installed on ties not perpendicular to the form face are subjected to eccentric loading that can cause tie failure.

6. Batter Plate Castings, with mating Cast-Contour Nuts, should be installed to support 50K ties that are not perpendicular to the form face.

The 96K Batter Washer is used with the 85K She-Bolts or 96K Taper Ties.

7.
  - a. Taper Tie Hammering Caps are available in two sizes: 1" contour thread or 1 1/4" contour thread.
  - b. The correct diameter and thread-type Hammering Cap must be utilized during initial impact release of embedded Taper Ties.
  - c. The Hammering Cap is positioned at the smaller diameter end of the taper tie. The protruding end of the Hammering Cap is then struck with an 8 lb. or heavier sledgehammer. All mushrooming type impact damage is accumulated at the end of the Hammering Cap, rather than the butt end of the Taper Tie so as not to damage tie threads.

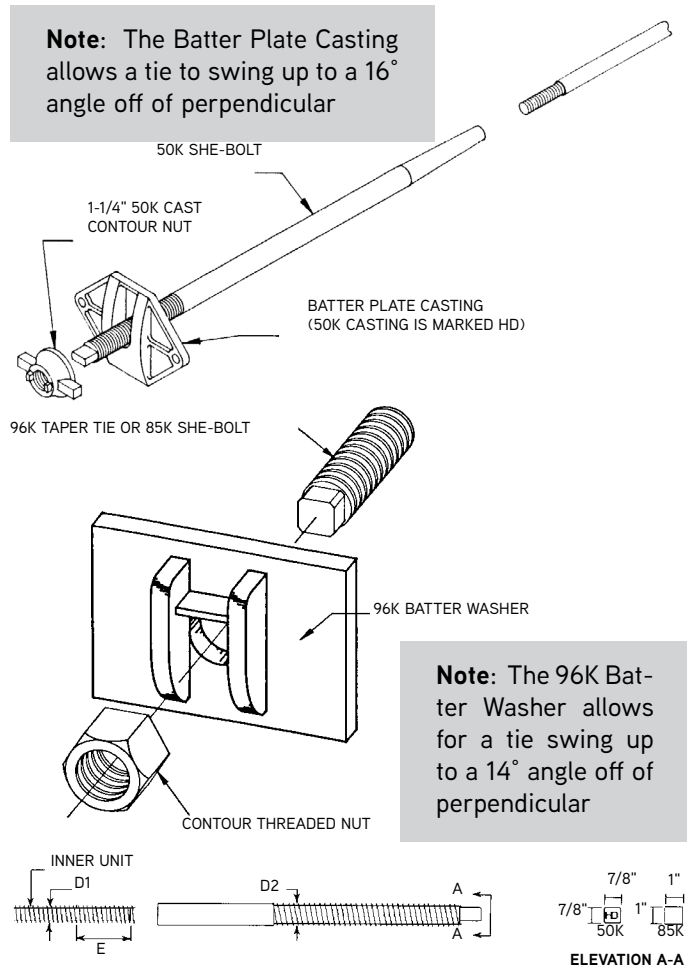

**She-Bolt Capacities and Thread Dimensions**

DESIGNATION	D1	D2	E	ULTIMATE STRENGTH	SAFELOAD CAPACITY AT 2 TO 1 SAFETY FACTOR
50K	7/8"	1-1/4"	2"	50,000 LBS.	25,000 LBS.
85K	1-1/8"	1-1/2"	2-1/4"	85,000 LBS.	42,500 LBS.

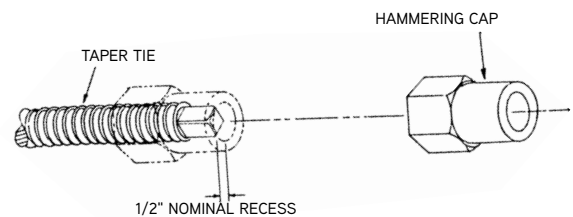

**Note:** The 1/2" nominal recess dimension is critical:

- It assures that all of the threads of the nut portion of the Hammering Cap mesh to withstand the transfer of sledge-hammer impact to the Taper Tie.
- It provides a safe clearance between the butt end of the Taper Tie and the striking sledge-hammer.



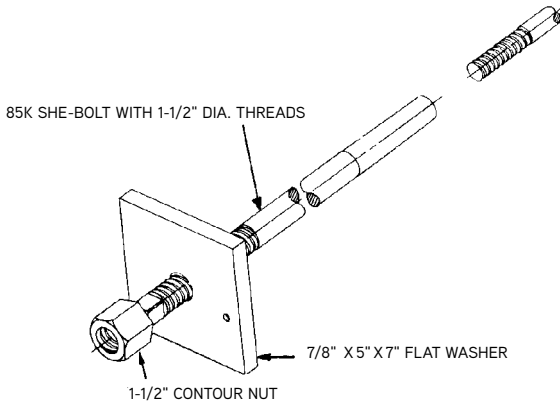

**85K She-Bolt**

**D. Top Tie/Lift Bracket**

Tying to the edge rails is accomplished with the M/F Top Tie/Lift Brackets, Top Ties or Bottom-Ties. These are shown below, and are fastened with speed bolts to the rails. The bolts are inserted through the 13/16" holes in the panel not through the slots.

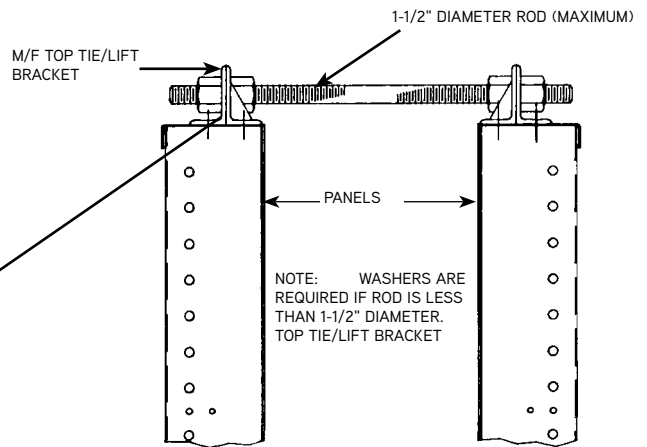

LIFT LOAD RATING: 8,000 LBS AT 5:1 SAFETY FACTOR  
 TIE LOAD RATING: 9,800 LBS AT 2:1 SAFETY FACTOR (3 BOLTS ON 2 GAUGE LINES)  
 2,000 LBS AT 2:1 SAFETY FACTOR (3 BOLTS ON 1 GAUGE LINE)

**Top Tie/Lift Bracket**

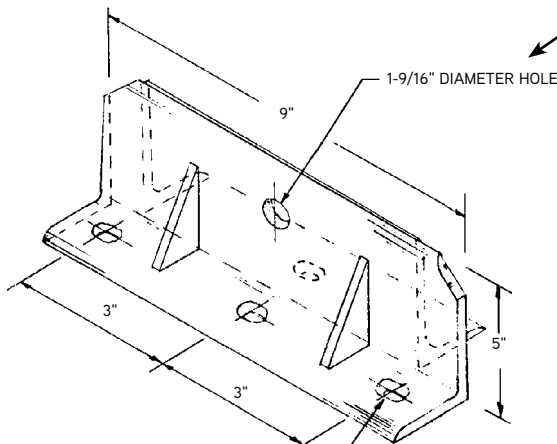

13/16" X 1" SLOTS (4 EACH)

(2) SPACERS

**Bottom Tie**

(Refer to Bottom Tie Applications)

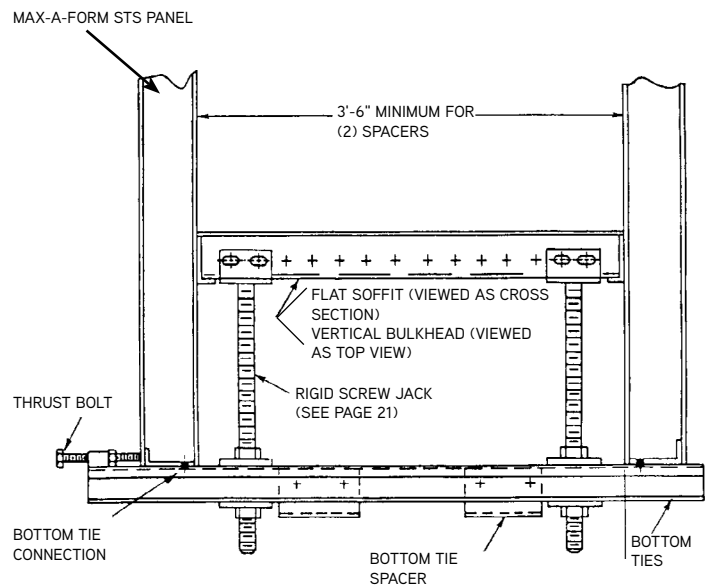

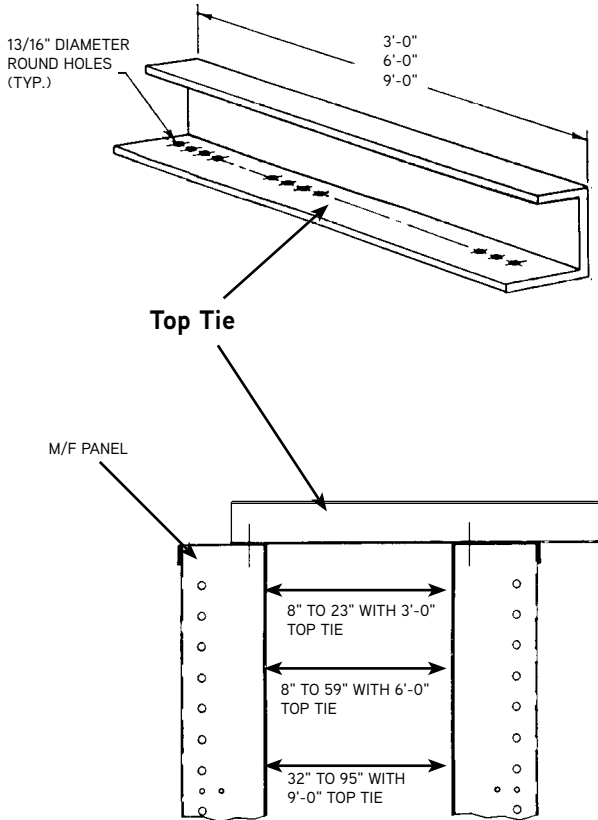

**E. Ladder**

Access to large Max-A-Form STS gangs with walkways is simplified with the use of Ladder Brackets and Column Form Ladders. This application, illustrated in the drawing, provides safe climbing to various work levels.

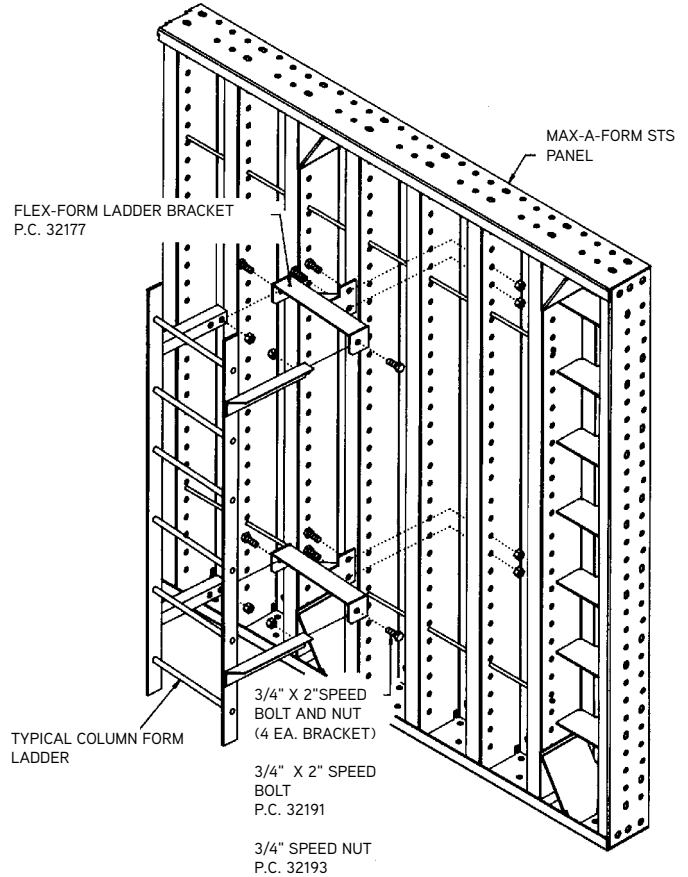

### III. GANG ASSEMBLY

#### Tools

The following list of tools will help construction personnel erect Max-A-Form STS gangs and tighten nuts on bolts and ties.

- 1¼" Socket, ½" drive
- Socket Wrench, ½" drive
- Adjustable wrench, 12" length
- Box or Open end wrenches for ties:
- Symons by Dayton Superior Pry Bar
- Oil for threaded parts
- Spud Wrench
- Handling Hook

#### Site Selection

1. The gang assembly site should be chosen before the arrival of the Max-A-Form STS equipment and should meet the following criteria:
  - ◆ The site should be within reach of the crane to both unload the truck and to position the Max-A-Form STS panels for assembly.
  - ◆ The site should be as close to where the gangs are going to be used as possible
  - ◆ The surface area of the gang assembly site should be reasonably flat and level.
  - ◆ A large storage area next to the gang assembly area is desirable in that it allows all like components to be stacked together in an efficient manner.
2. Prepare the assembly site by cleaning away debris and laying down 2x6 or 2x8 lumber sleepers. The lumber should be positioned at all joints between panels and at panel ends. The lumber provides a flat plane and a common bearing surface for adjacent panels. It also protects the panel face from ground-contact damage.

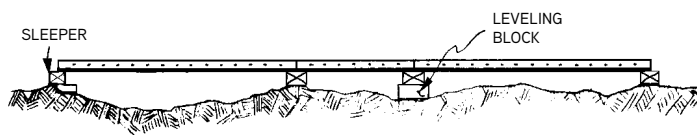

Typical Assembly Site



Handling Hook  
P/C F1409100

#### Bolt-Up

1. Utilize the Max-A-Form Handling Hook to shake out the panels and begin the assembling process. Lay the panels face down on the prepared surface in their proper locations. Be sure that the tie holes in each panel are toward the bottom of the gang in vertical-stiffener gangs. Remember that opposite sides of walls are mirror-image gangs. And the forms are assembled accordingly (so the tie holes match).

Hint: When assembling panel gangs, snug bolts finger tight until gang is totally assembled. Then wrench tighten after checking final alignment.

2. Use spud wrench or drift pin to correctly align bolt holes and form edges. Place the ¾" x 2" speed bolts in the face side gauge line at one foot on center in the 1³⁄₁₆" x 1¼" slots in the side, top, and bottom rails, as appropriate. All bolts should be snug tight plus ⅓ additional turn. This bolting method is for Max-A-Form STS wall forming, not self-spanning applications.
3. Occasionally shims may be required for horizontal and vertical panel joint alignment. If leakage is to be reduced, install rubber gaskets at joints.
4. Additional speed bolts should be used in the second gauge line to increase the stiffness.
5. The basic gang is complete when the forms are fastened together. However, the contractor may attach appropriate accessories before raising the gang.

**Caution:** When gangs are more than two panels high, it may be necessary to add strongbacks to the gang before raising to the vertical position. Check with your Symons by Dayton Superior representative for this condition.

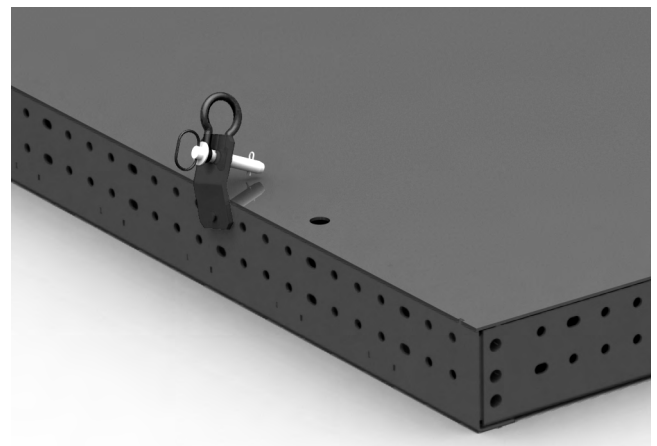

Handling Hook on Panel - Four (4) Required

**A. Accessory Installation**

All accessories are attached to the gang with the 3/4" x 2" speed bolt.

**1. M/F Top Tie/Lift Brackets**

Lift Brackets are installed with three speed bolts and nuts.

The following safety rules must be followed:

- a. Lift Brackets are the only attachment points for crane rigging, and they must be properly spaced and attached to the gang.
- b. The safe load rating of the lifting bracket is 8,000 pounds at 5:1 Safety Factor.
- c. The rigging must be designed by the contractor to assure that any one Lift Bracket is not overloaded. Spreader beams are recommended for all lifts with three or more lifting brackets.
- d. A minimum of two tag lines must be used to control the gang movement. Do not allow personnel on or directly under any gang form while it is being moved or suspended in air.

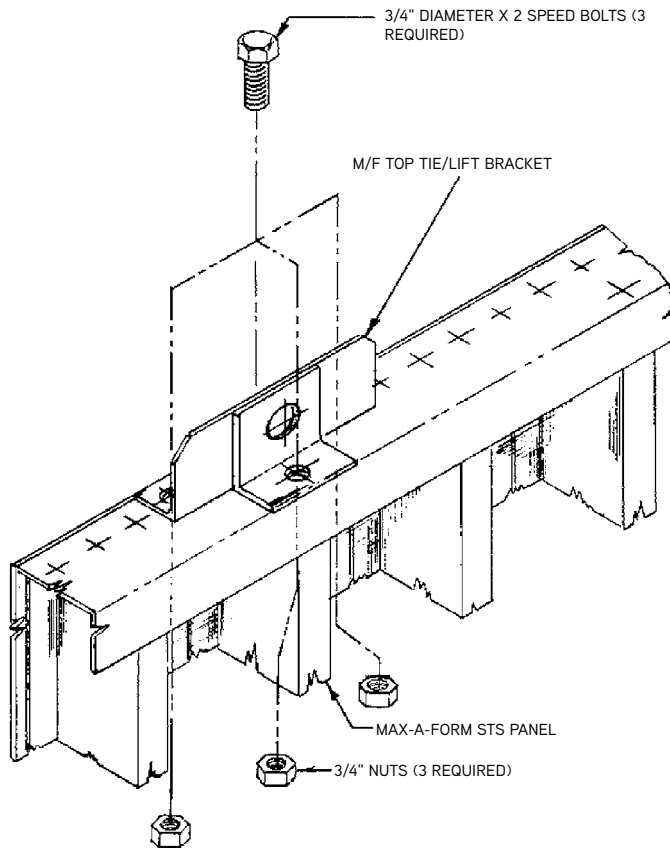

**Max-A-Form STS Top Tie/Lift Bracket Installation**

- e. Gang forms should be adequately braced, re-anchored, or otherwise secured prior to releasing lifting mechanism.

**2. Wide Walkway Brackets**

A work platform supported by walkway brackets is the recommended method of providing safe access for working on the forms when pouring concrete, and installing or stripping wall ties. The work platform should be erected in accordance with the applicable industry regulations and be equipped with guardrails, midrails and toeboards along all open sides and ends. Furthermore, walkway brackets should not be used to support loads other than personnel.

Normal attachment of the walkway bracket to Max-A-Form STS with the interior stiffeners in the vertical position is done using two speed bolts. When the interior stiffeners are horizontal, four speed bolts are needed, two (2) in each leg.

**Caution:** The 3/4" bolt must always be positioned through the hole of the horizontal and diagonal members of the walkway bracket.

The Wide Walkway Bracket has a safe load rating of 750 pounds. The brackets should be spaced 8 feet on center or less.

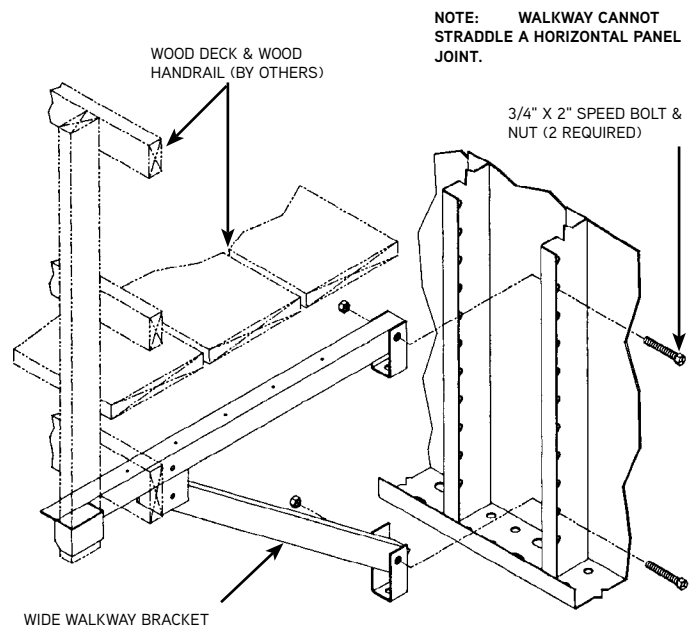

**Wide Walkway Bracket Installation for Vertical Stiffeners**

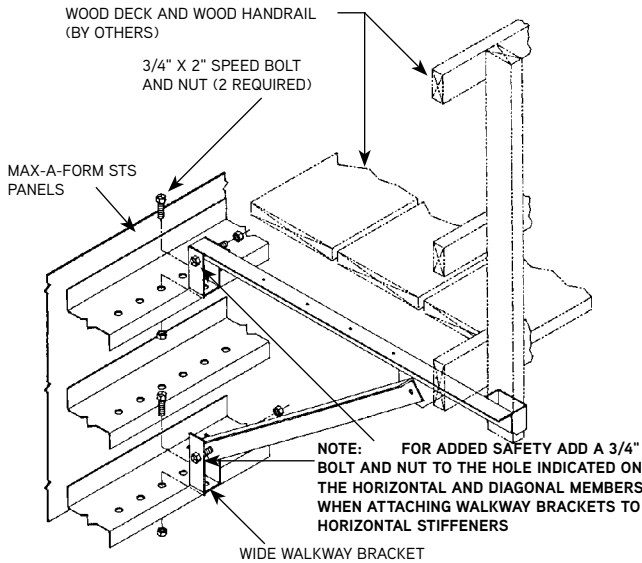

**Wide Walkway Bracket Installation for Horizontal Stiffeners**

3. Alternate Walkway Bracket

This bracket can only be used when the interior stiffeners are vertical. It attaches to the Max-A-Form STS with two speed bolts. A guardrail support member is fastened to the alternate walkway bracket with two more speed bolts. The safe capacity of this bracket is 800 pounds, and it is also spaced 8 feet or less on center.

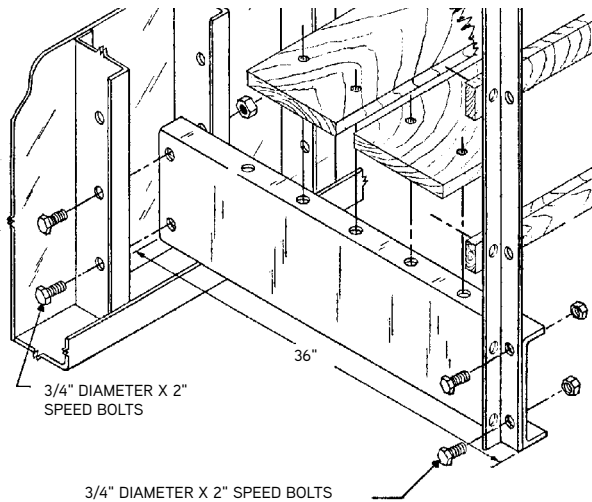

**Alternate Walkway Bracket Installation**

4. Walkway Mount

The Walkway Mount provides a means of hanging a scaffold below the bottom of the Max-A-Form STS panels. This can be very useful on multi-lift forming conditions by providing access to the bottom ties. As shown in the accompanying illustrations, the Walkway

Mount is attached to either the bottom of the panel or to a vertical interior stiffener with two speed bolts and nuts.

The Alternate Walkway Bracket is fastened to the Walkway Mount with two Speed Bolts.

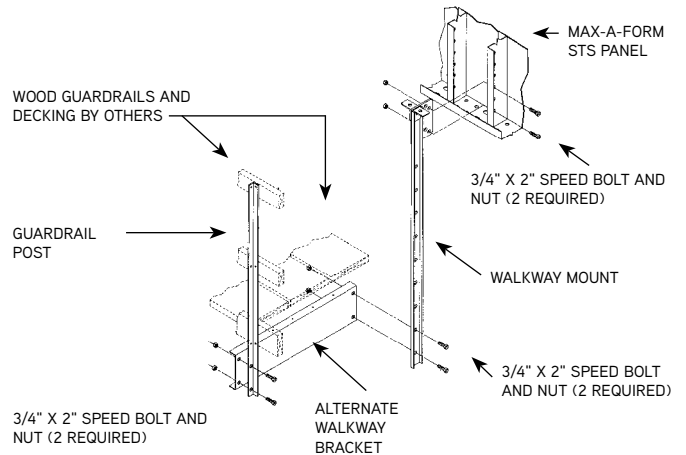

**Max-A-Form STS Hanging Scaffold Erection (Vertical Stiffener Configuration)**

**Caution:** The 3/4" bolt must always be positioned through the hole of the horizontal and diagonal members of the Walkway Bracket.

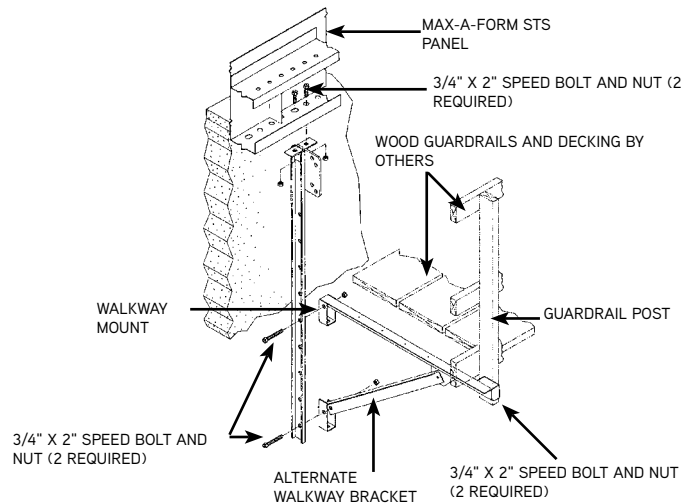

**Max-A-Form STS Hanging Scaffold Erection (Horizontal Stiffener Configuration)**



5. Waler Attachment Bracket

The Waler Attachment Bracket is used to attach a Versiform® waler to stacked Max-A-Form STS panels. This is usually done when conditions call for alignment or load gathering walers. The bracket is bolted to the Max-A-Form STS with a 3/4" Speed Bolt. The bracket is fastened to the waler with a 5/8" Fit-Up Bolt. A minimum of two brackets are required per panel.

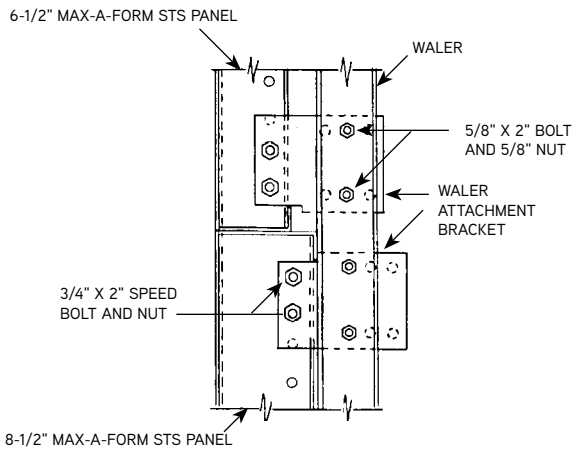
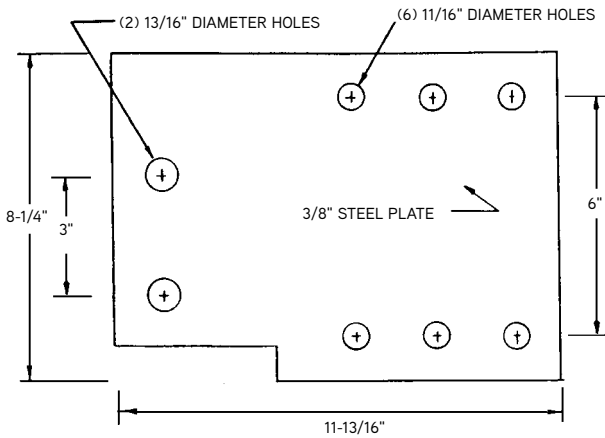

**Stacking for Alignment Waler**

6. Pipe Form Aligner

- a. The Symons Pipe Form Aligner is adjustable from 13'-3" up to 20'-9". Its purpose is to position forms straight and plumb and is not intended to resist lateral loads.
- b. The Pipe Form Aligner may be connected to the vertical panel stiffeners by utilizing the Pipe Form Aligner Adapter.

**Caution:** Wall and column forms must be adequately braced to safely support all foreseeable lateral loads associated with wind, eccentric loading, etc. The materials, quantities, locations and methods of attachment and anchorage of the bracing design shall be the responsibility of the contractor based on job site conditions and applicable industry standards.

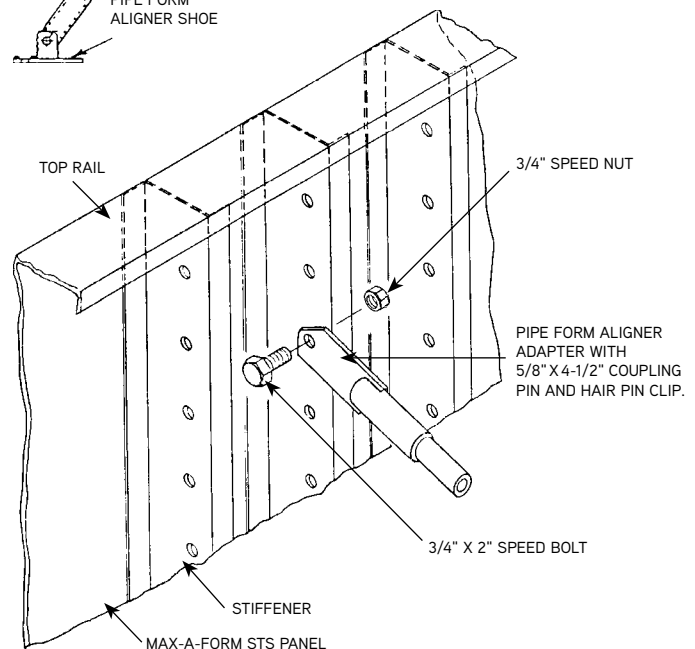
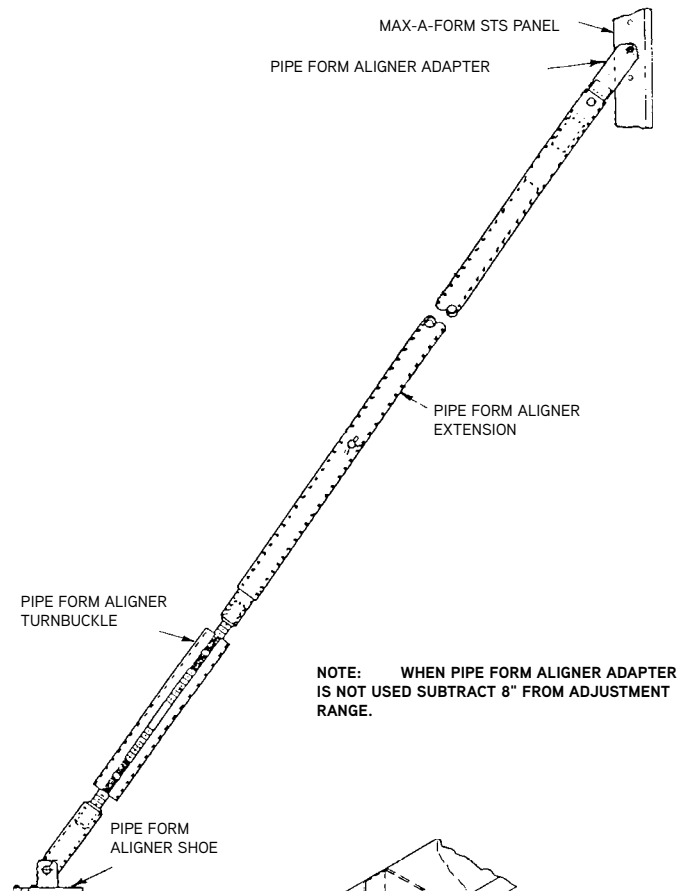

- c. A Pipe Form Aligner Shoe is utilized at the ground end of the Pipe Form Aligner. It has a  $\frac{3}{16}$ " diameter hole for anchoring with a  $\frac{3}{4}$ " diameter concrete anchor bolt, and a rectangular slot for anchoring with a Symons steel stake driven into the ground.

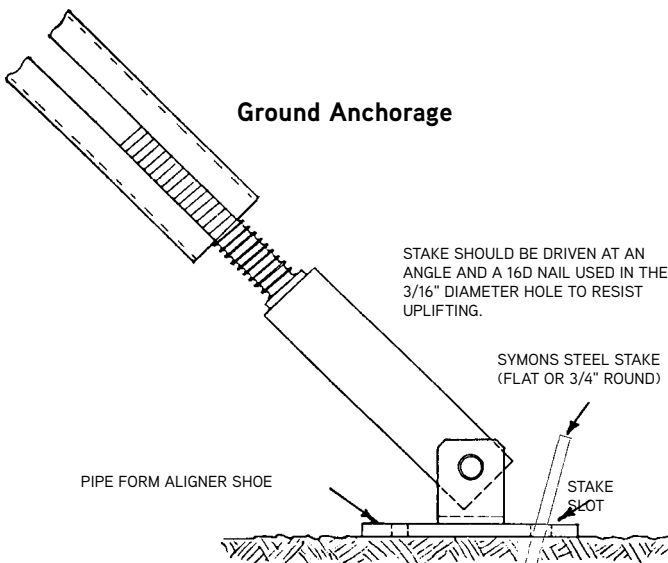
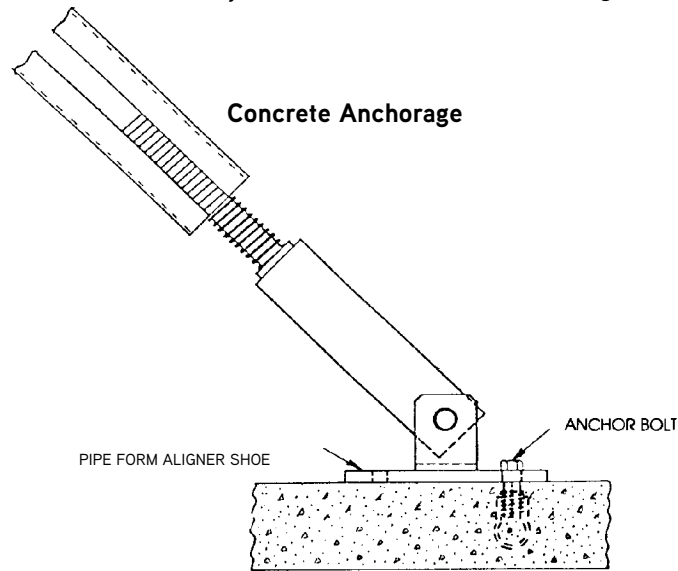

## 7. Pier Cap Brace

For shorter brace lengths, the Pier Cap Brace is used. A Brace Bracket is fastened to two vertical stiffeners with two speed bolts. A Stability Beam Shoe is bolted to the Brace Bracket and attached to the brace. At the other end of the brace attach a Stability Beam Shoe or a Pipe Form Aligner Shoe, and anchor as required. The Pier Cap Brace and its extensions, have a length range from 6'-6" to 13'-6".

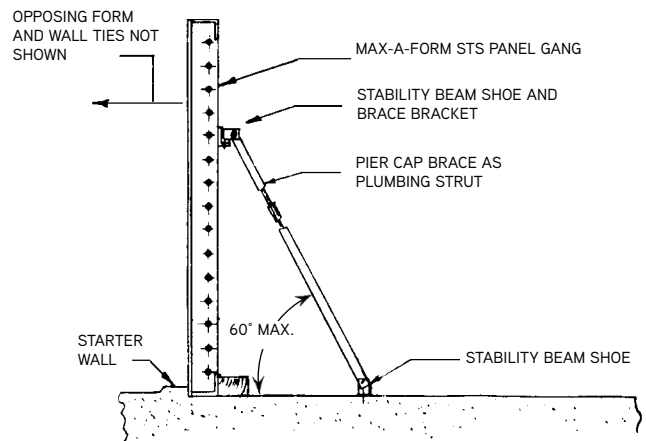
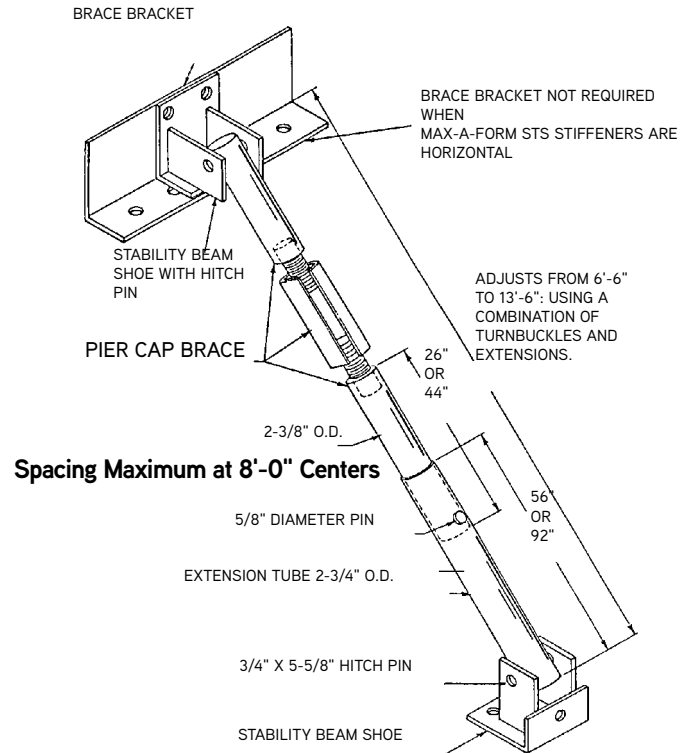

## 8. Walers

- Standard 5" Versiform® Walers are double 5" steel channels that are welded together through integral plate gussets which space them back-to-back 3" apart. 5" walers are available in six standard lengths.
- Standard 8" Versiform Walers are double 8" channels welded together through integral plate gussets which also space them 3" apart. 8" walers are available in five standard lengths.

9. Max-A-Brace

- a. The Max-A-Brace is adjustable from 22'-8" up to 30'-9". Max-A-Brace telescopes in 3" increments and has a  $\pm 6"$  threaded adjustment at the lower end.
- b. The fixed end of the Max-A-Brace connects to bracket components that allow the brace to hang parallel to forms when gangs are lifted and moved.

**Caution:** Wall and column forms must be adequately braced to safely support all foreseeable lateral loads associated with wind, eccentric loading, etc. The materials, quantities, locations and methods of attachment and anchorage of the bracing design shall be the responsibility of the contractor based on job site conditions and applicable industry standards.

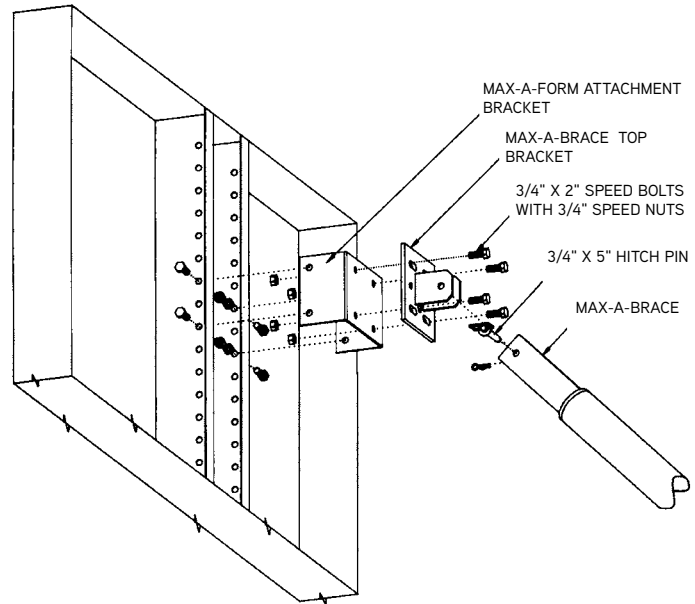

**Max-A-Form STS Attachment Bracket and Max-A-Brace Top bracket connection to Max-A-Form STS panel with vertical stiffeners**

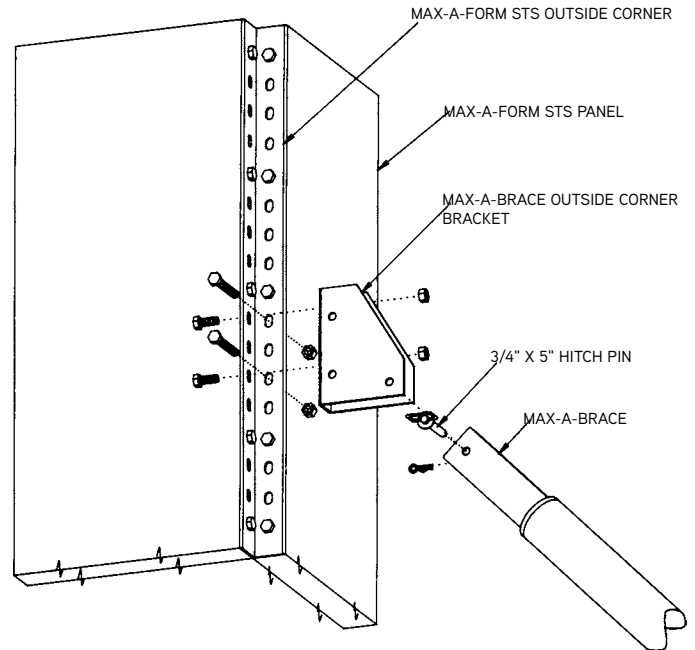

**Max-A-Brace Outside Corner Bracket Connection to Max-A-Form STS Column Form**

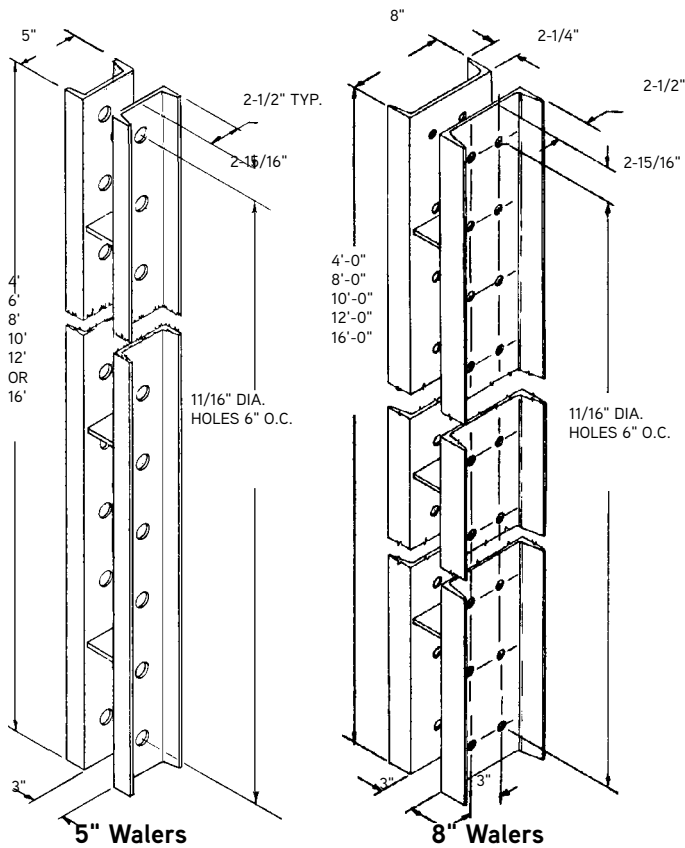

## B. Gang Care and Placement

### 1. Care of Max-A-Form STS Gangs

The most important item of Max-A-Form STS gang care is the use of a good form face coating, such as Symons Magic Kote®. Magic Kote allows the forms to strip easily and reduces concrete build-up. It also protects the forms against rust and corrosion, and reduces the form cleaning time between pours.

It is recommended that a visual inspection of the Max-A-Form STS gang be performed between reuses of the form. Look for loose bolts, bent or deformed panel members, and broken welds. Although Max-A-Form STS is a strong forming system, a gang is most apt to be damaged by overloading and by mishandling. By adhering to the design pressure specified on Symons drawings or specifications, the Max-A-Form STS should perform admirably. By stripping the Max-A-Form STS after all the ties are loosened and by lifting and setting the formwork with minimal impact loads, the Max-A-Form STS will hold-up for many pours.

The periodic removal of any build-up of concrete in the recesses of the back side of the form is recommended. The build-up can add substantial amounts to the weight of the gang.

### 2. Gang Placement

A simple four step procedure is used to set the Max-A-Form STS gangs in place. In each of the steps listed below refer to the accessory section of this application guide for the proper use of necessary accessories.

The first step is to attach the rigging to the first gang to be positioned, usually the braced side of the wall. The rigging is attached to the M/F Top Tie/Lift Brackets, and the gang is raised, swung into position, and lowered to its location.

Secondly, secure and anchor to a solid fixture. Plumb the gang with the braces and remove the crane rigging.

**Caution:** Never remove the rigging from the gang until the gang is properly anchored and braced.

Next, attach the rigging to the M/F Top Tie/Lift brackets on the gang meant for the opposite side of wall. Raise and swing it into place, making sure that the proper wall thickness is achieved (a sill plate or chalk line helps). Be sure the ends of the gangs line-up and/or that the tie holes are aligned.

Finally, secure the form to the previously braced gang by attaching the top ties and installing the through ties. (See the Tying procedures section of this guide for proper tie usage).

The above procedures can be used for single and multiple lift gang forming conditions. The main difference between single lift and multiple lift forming is the landing surface. On single lift forming or the first lift of a multiple lift condition the landing surface is usually a relatively large continuous surface. On the upper lifts of a multiple lift system, the landing surface is two or more support jacks or a ledge supported by same.

To minimize lifting stresses, a gang in the vertical position should remain vertical throughout the job, even while storing, to avoid the bending stresses applied to horizontal joints by lifting the horizontal forms to the vertical.

**C. Accessories and Applications**

**1. Battered Walls**

- a. Battered forms are subjected to a vertical component of pressure. The amount of up-lift force will depend on the degree of batter, height of wall, and anticipated maximum concrete placement pressure. A reasonable estimate of up-lift pressure must be made, so that necessary resistance to up-lift can be installed; such as adding weight or tying down to the footing.
- b. Since ties will not be perpendicular to both form faces, Batter Plate Castings and Cast Contour Nuts must be used with 50K ties and 96K Batter Washers used with 85K She-Bolts or 96K Taper Ties.
- c. The maximum batter that can be achieved with Max-A-Form STS is 1:12.

**2 Bulkheads**

These can be formed of wood, plywood, Steel-Ply®, Stay-Form™, and any combination thereof. Bulkheads must resist concrete pressures while allowing rebar penetrations. Unless there are many identical bulkhead applications, a job-built form is usually acceptable.

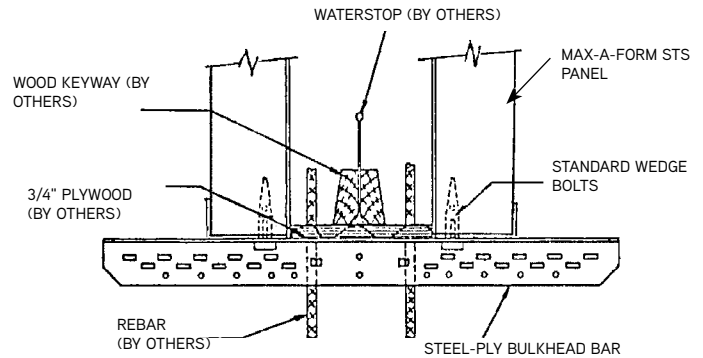

**3. Job-Built Fillers**

When a job-built form (JBF) is needed for dimensional or other purposes, a filler angle is bolted to the Max-A-Form STS on either side, and 3/4" plywood is inserted as sheathing. Studs may be required to carry the design pressure.

**Caution:** Avoid using job built fillers next to bullnoses, corners and anywhere "Pull Out" loads are present.

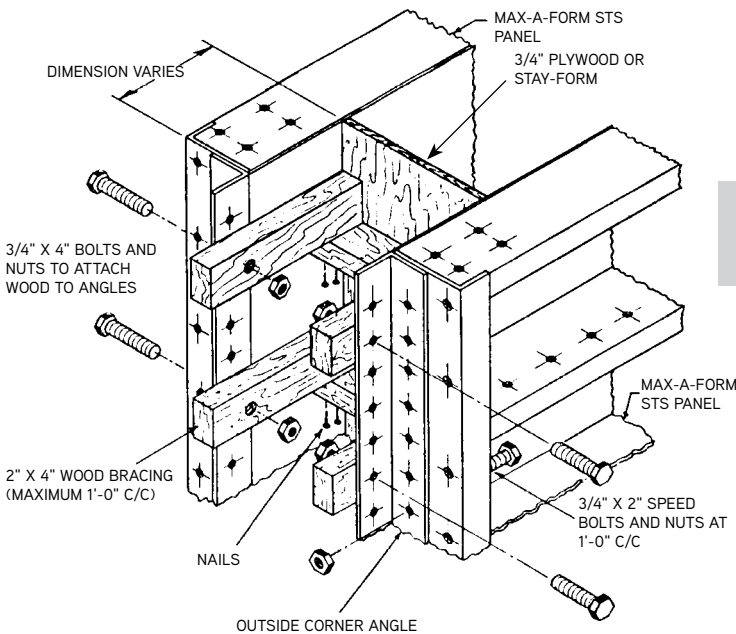

**Outside Corner Angles used for End Bulkheads  
Maximum width 2'-0"**

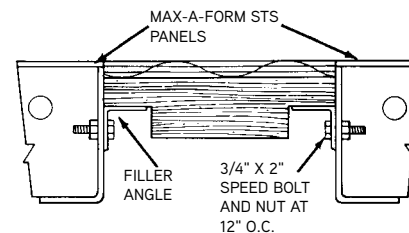

**3/4" Plywood with 2" x 4" wood backing**

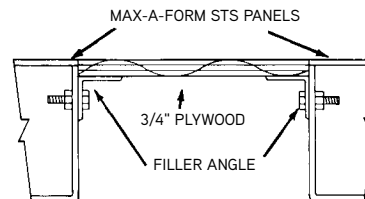

**3/4" Plywood without 2" x 4" wood backing**

(ADDITIONAL FILLER ILLUSTRATIONS ON NEXT PAGE)



ATTACH FILLER ANGLES TO PANELS WITH 3/4" X 2" SPEED BOLTS AND NUTS

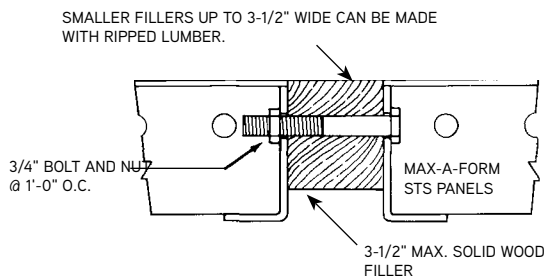
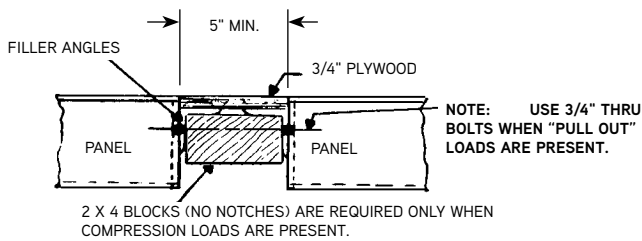
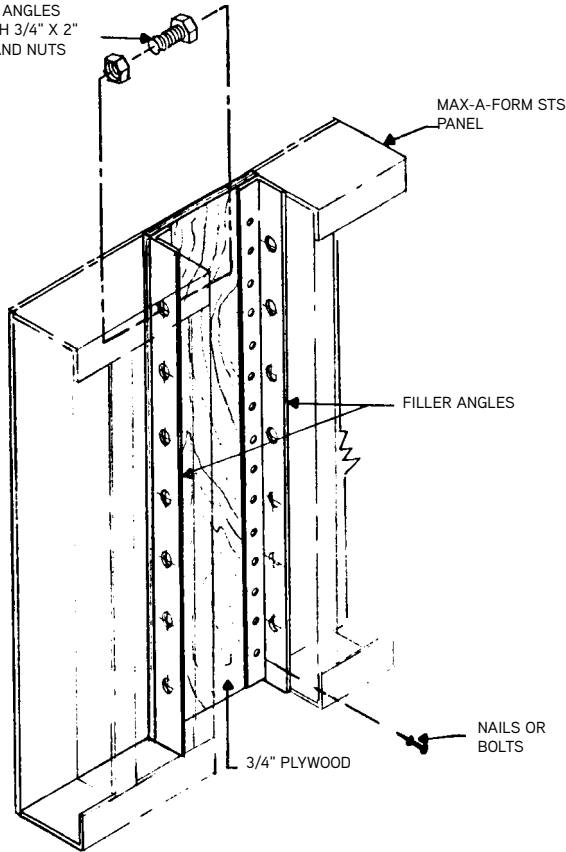

#### 4. Corners

- a. The Combination Rigid Corner can be used to form both 90° inside corners and 135° inside corners. Each half has a product code, and two halves are required for a 90° corner. For a 135° corner, use half the assembly.

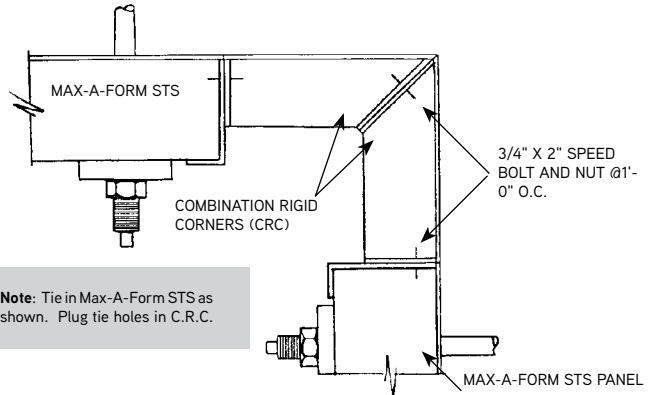

**Note:** Tie in Max-A-Form STS as shown. Plug tie holes in C.R.C.

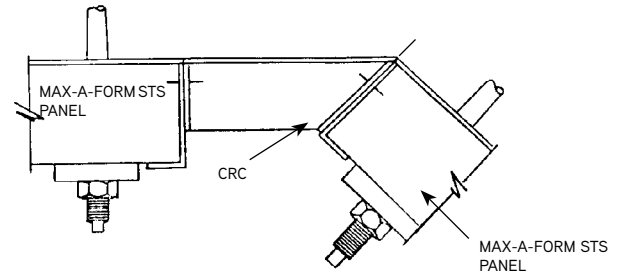

- b. The Inside Stripping Corner is used to form 90 degree inside corners. It facilitates easy stripping of gangs adjacent to corners or pilasters.

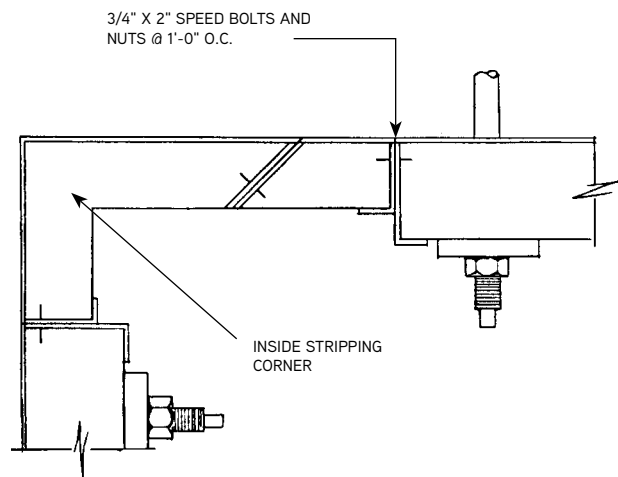

c. The Outside Corner Angle allows Max-A-Form STS panels to form 90 degree corners. The angle is bolted to the Max-A-Form STS at 1' on center, each leg.

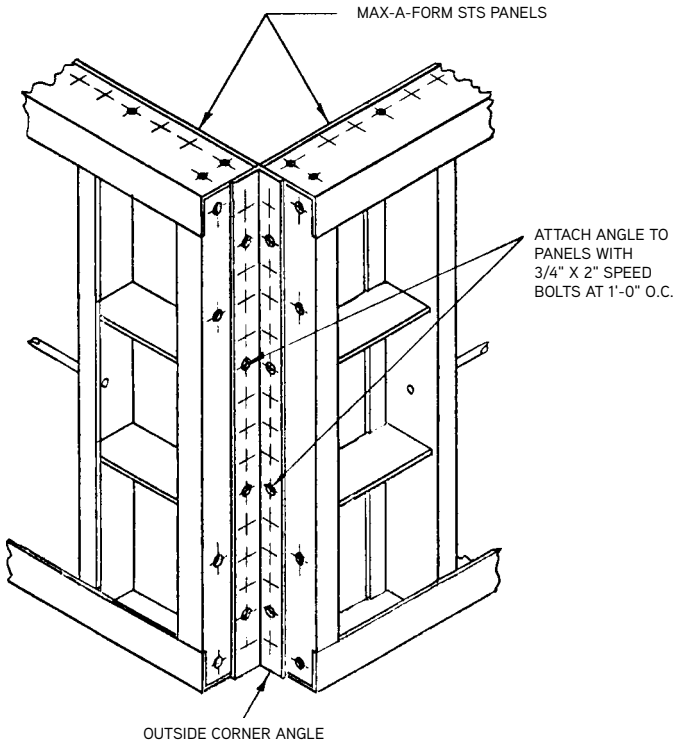

**D. Columns**

Max-A-Form STS is ideal for columns because it is strong and provides a good finish. Rectangular columns are formed with Max-A-Form STS panels while circular columns are handled with Circular Column Forms. Rectangular columns up to 12'x12'; can be formed without ties.

W = STIFFENER LENGTH

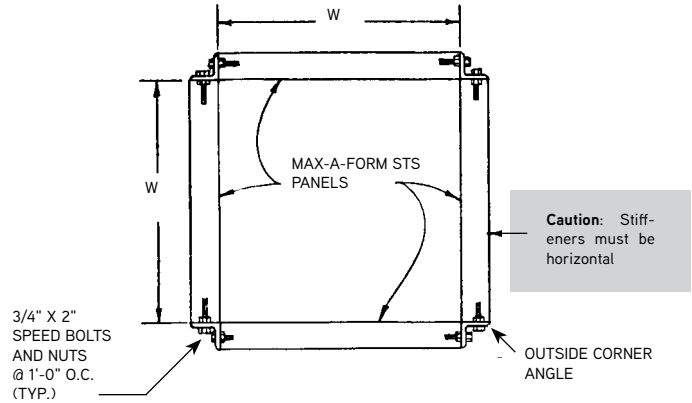

NOTE: CONCRETE POUR PRESSURE MUST BE REDUCED WHEN W IS GREATER THAN 8'-0" UP TO 12'-0". CONSULT WITH YOUR SYMONS REPRESENTATIVE.

When column dimensions are not in one foot increments, forms may be overlapped and bolted as illustrated below. Drill a 13/16" diameter hole through the skin plate and stiffeners.

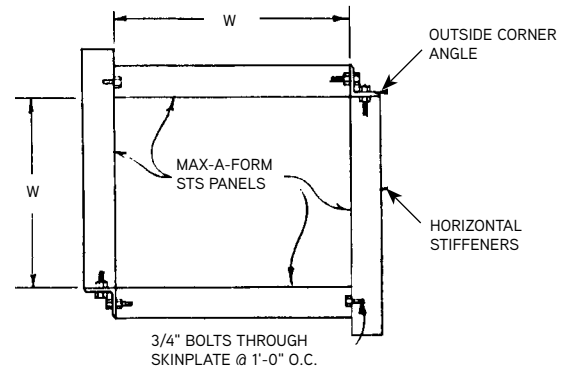
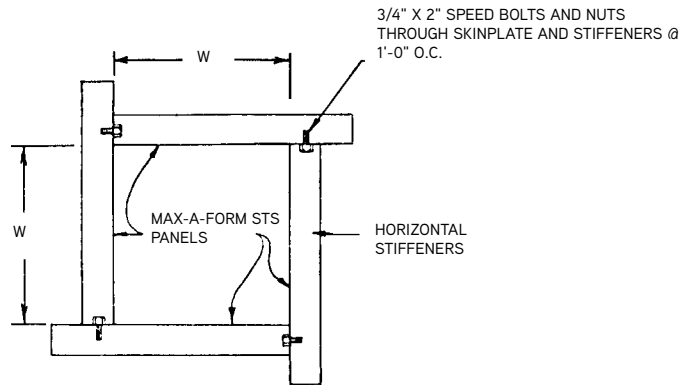

Note: When length W is greater than 8'-0" up to 12'-0" concrete pour pressure must be reduced. Consult with your Symons representative.

Hinged columns may be formed using the Corner Hinge Assembly. Each assembly is 9" long and requires four (4) 3/4"x2" bolts and four (4) 3/4" nuts. The spacing varies with column widths. Consult with your Symons representative for proper spacing and pour pressure.

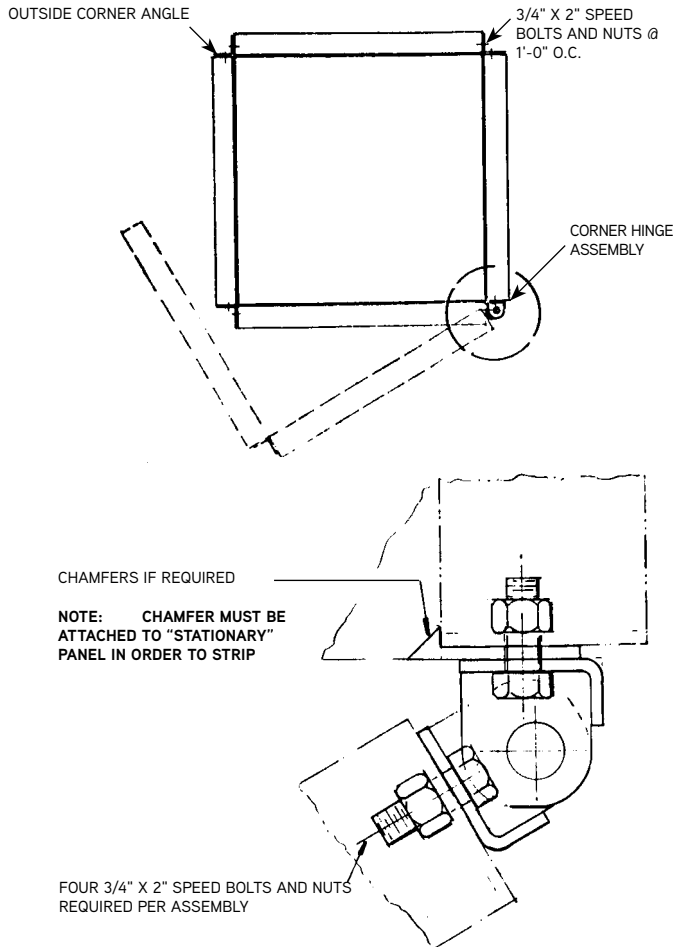

**Detail at Hinge**

Circular bullnose columns can be formed using Max-A-Form STS panels (with stiffeners horizontal) and Circular Steel Column Forms. Fasten Circular Column Form to Max-A-Form STS with 3/4" x 2" speed bolts at 12" on center. Always start and end adjacent to a horizontal bolting flange. Taper Ties or She-Bolts are required adjacent to the column forms.

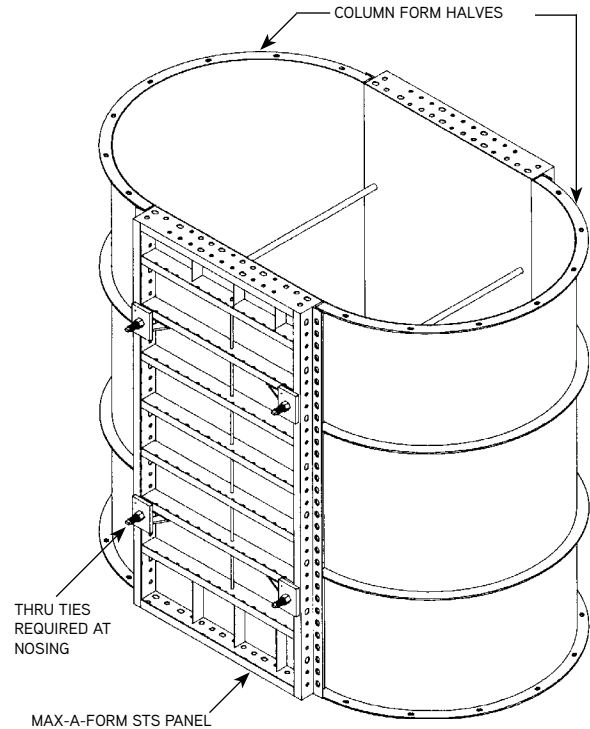

## E Tie Obstructions

Mismatched tie holes - When it is impossible to match tie holes, a waler must be added to replace the top or bottom rail as the load carrying member. Drill the tie hole in the skin plate at the required location and attach a 5" Versiform Waler to the panel. The tie can then be inserted through the waler, through the tie hole in the panel and through the tie box of the opposing panel. The waler must run the entire length of the panel. Sometimes an alternate tie location is necessary in some places because of imbedded items such as weld plates, pipe flanges, rebar, post tensioning ducts, electrical fixtures and other mechanical devices. The following illustrations show how to use a waler for alternate tie locations.

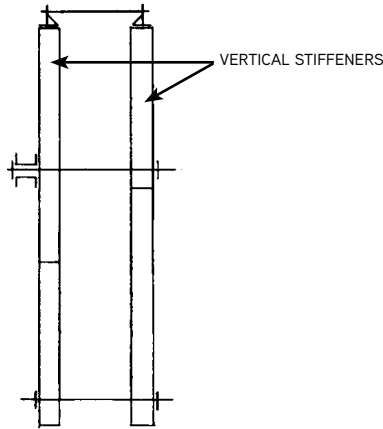

**Using a Versiform Waler to Correct Vertical Misalignment**

Remember that holes drilled into the panel will result in repair charges to rented equipment. Also a longer tie is required to go through the additional thickness of the waler.

In the Raised Form illustration, a 12" Max-A-Form STS panel is bolted to the bottom of the vertical panel. This allows the tie to be 15" above the floor. This method is useful when a starter wall has been poured and the normal 3" tie height is not adequate.

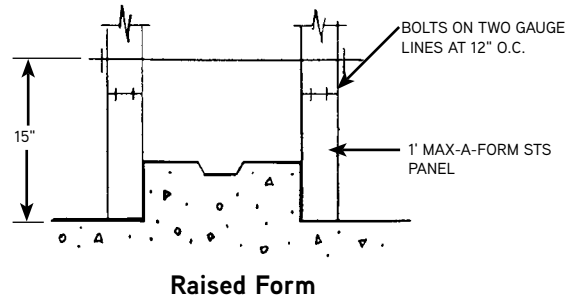

**Raised Form**

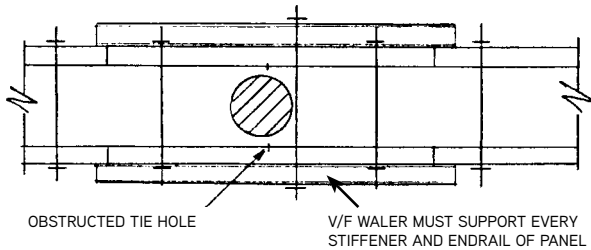

**Using a Versiform Waler to Avoid Obstructions**

#### IV. MAX-A-FORM STS SELF-SPANNING APPLICATIONS

Generally, concrete forming systems are divided into vertical and horizontal applications. Vertical forming systems are designed to resist concrete pressure only. Since the weight is carried by the ground or a previous pour. Horizontal forming systems, often called shoring are designed to support concrete weight and live loads, but usually little pressure.

Forms that can resist lateral concrete pressures and vertical concrete weight together, are known as self-spanning forms. Max-A-Form STS is such a form, and this type of form has economies built into it. When shoring is impractical or impossible, Max-A-Form STS is even more attractive.

##### A. Assembly

1. Select the assembly site, with the qualities mentioned in the gang assembly section.
2. Soffit:

Layout the overall dimension of the soffit considering the column openings, and place flat 2x lumber sleepers at the form joints and at reasonable intermediate spacings. Level this support platform as well as possible.

3. Place soffit face-down and bolt together. Bolt the Outside Corner Angles to the soffit forms. Verify all locations with the layout drawings. Install the  $\frac{3}{4}$ " bolts through the round holes, not the slotted holes. Bolts are spaced 1' on center (unless noted otherwise) on alternate gauge lines. All bolts should be snug tight plus  $\frac{1}{3}$  additional turn.
4. Place the Stability Beams on the soffit panels (unless soffit is to be inset) and connect the beams to interior stiffeners with 2 each Clip Angles and speed bolts. Verify that all the dimensions and beam cantilevers are as prescribed. Thrust bolts should all be on the same side.
5. For sloped or flat inset soffits attach the Swivel Jacks or the Rigid Jacks respectively to the interior stiffeners as shown on the layout drawings. These will be attached to the Bottom Ties later. Attach the temporary lifting brackets and flip the soffit forms. Realign the soffit assembly as required.

Another method of erecting the soffit is to build an elevated work platform. Place the Stability Beams on the platform. Place the soffit panels, face up, on the beams. Bolt the Max-A-Form STS panels together from underneath and attach the Stability Beams using the Clip Angles.

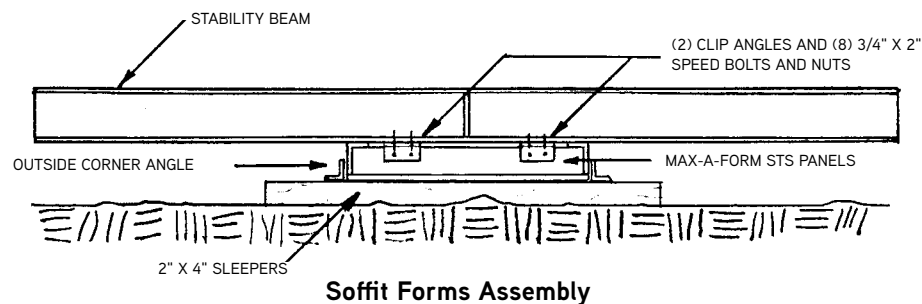

Soffit Forms Assembly

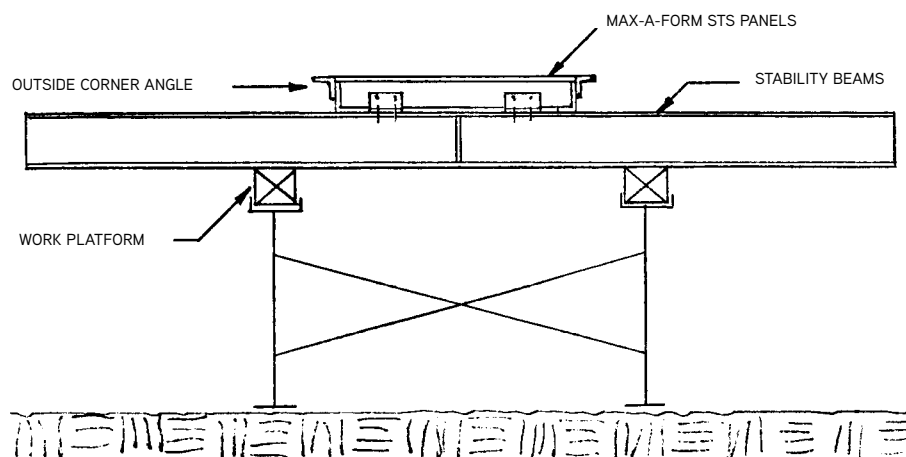

Alternate Method



6. Assemble the cap braces to the desired lengths and attach the shoes and Brace Bracket. Attach the side panels along one side of the soffit by bolting 1' on center along the Outside Corner Angle. Brace the side panels with the Pier Cap Braces bolted to the Stability Beams. The cap brace should be between 30° and 60° from the horizontal. The Brace Bracket is bolted to the Max-A-Form STS side panel near the top (top third) of the form.
7. Align the side forms as they are installed. Insert two Girder Bolts at the top and at the bottom of all side form joints. All bolts should be snug tight plus 1/3 additional turn.
8. The rebar cage may be installed at this time. The second side is erected in the same fashion as the first. Sloped soffit forms should have both sides installed before inserting the rebar cage.

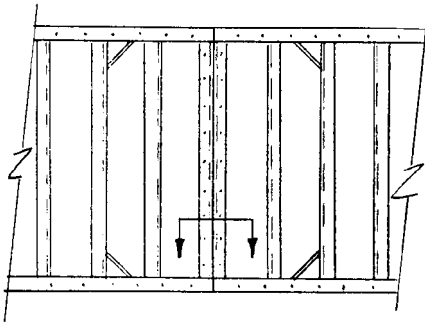
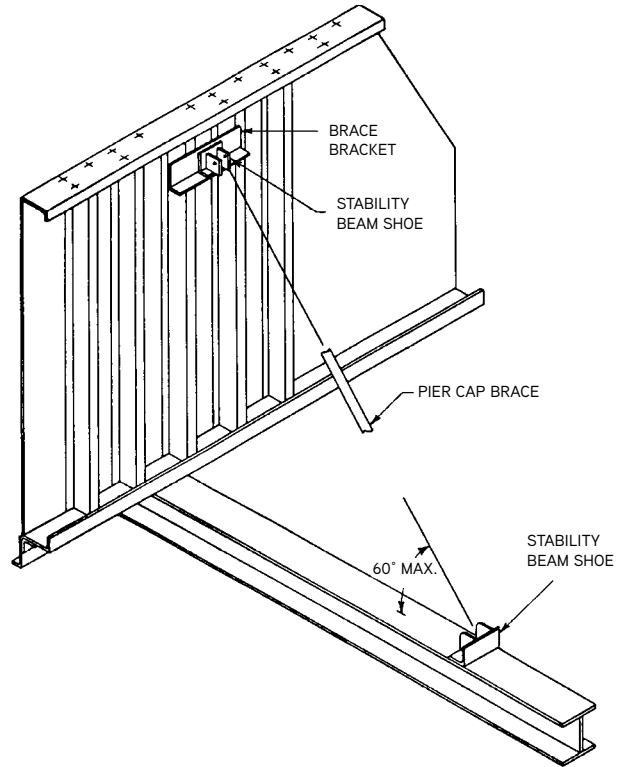

**Note:** Adjacent forms must be of equal width in self-spanning applications so that all girder bolt positions will align.

9. If a sloped soffit is involved, connect the Bottom Ties and the Stability Beams to the side forms with 3/4" bolts. Be sure that the Swivel Jacks and/or extensions are between two bottom tie halves. Bolt all necessary brackets and ties, and verify that all connections are secure.
10. Install the rebar cage (if not done yet), and install the end forms. Attach other accessories such as lifting brackets, walkway brackets, chamfer strips, and spreader beams.

**Caution:** Sloped soffits must be restrained horizontally by bolting through side panels.

11. Install the top ties to the Max-A-Form STS side panels at the specified intervals. Check every panel joint and connection.

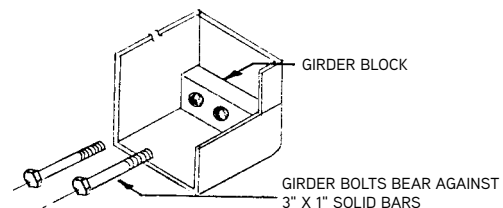

TYPICAL PANEL CORNER SHOWING GIRDER BOLT CONNECTION WITH TWO (2) 1" DIAMETER A490 GIRDER BOLTS

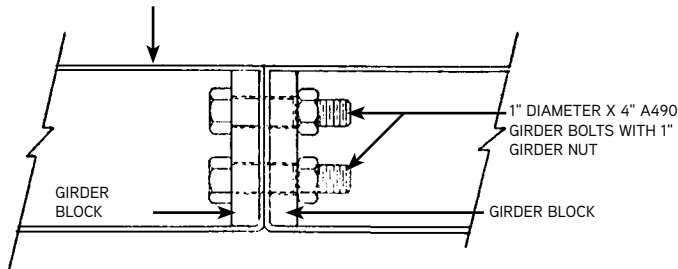

**Caution:** Never use bolts and nuts that do not turn freely for the full thread length.

## B. Bottom Ties

Bottom Ties are required where soffits are inset or sloping. The maximum allowable spacing is 3'-0" on center on soffits greater than 8'-0" wide and 4'-0" on center for soffits 8'-0" wide or less. The bottom ties not only act to hold the side forms together but also to support the soffit either through Rigid Screw Jacks (for flat soffits) or Swivel Screw Jacks (for sloping soffits). Bottom Ties come in two halves with a Thrust Bolt assembly welded to both. The total allowable load transferred from the two screw jacks is 24,000 pounds (at 2:1 factor of safety) divided equally between side panel connections (12,000 pounds per side).

## C. Soffit Support

### 1. Rigid Screw Jacks

Two jacks maximum are allowed per Bottom Tie. Rigid Screw Jacks are used for flat soffits and vertical bulkheads. The adjustment range varies between 2<sup>5</sup>/<sub>8</sub>" minimum and 47<sup>3</sup>/<sub>8</sub>" maximum depending on combination of Bottom Tie and Rigid Jack used.

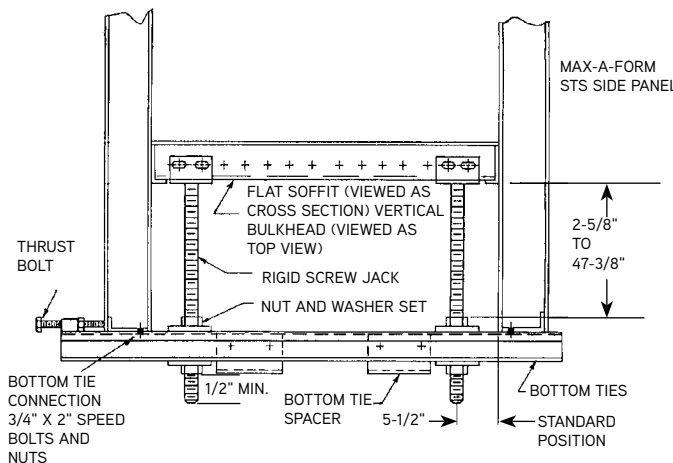

### 2. Swivel Screw Jacks

Two sizes of Swivel Screw Jacks are available to support sloped soffits and non-vertical bulkheads. The jacks must be perpendicular to the soffit panels. The maximum swivel is 35° to vertical in a soffit application. Two jacks maximum per bottom tie allow a 3" to 12<sup>1</sup>/<sub>2</sub>" or 3" to 19<sup>1</sup>/<sub>2</sub>" adjustment range for ties up to 7'-9", and 2" to 11<sup>1</sup>/<sub>2</sub>" or 2" to 18<sup>1</sup>/<sub>2</sub>" for ties 9'-9" and longer.

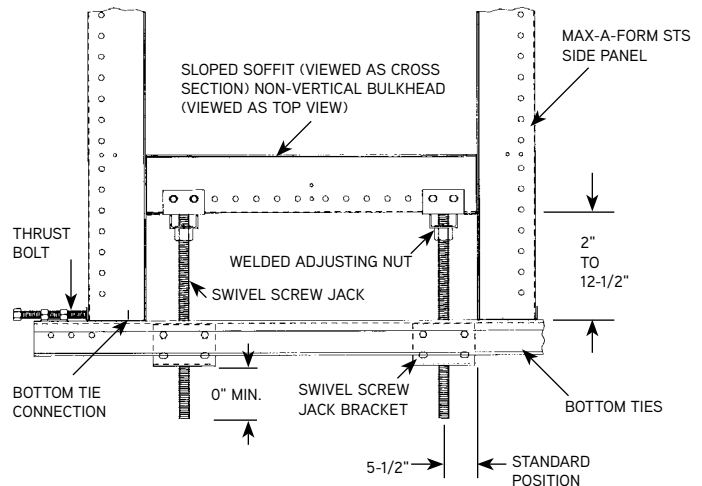

### 3. Extension Tubes

Two sizes of Extension Tubes are available for use with the Swivel Screw Jacks. The short tube provides an adjustment range from 13" to 37" when used with Bottom Ties up to 7'-9" long and 12" to 36" for 9'-9" and longer. The long extension range is 13" to 73" for ties up to 7'-9" and 12" to 72" for 9'-9" and longer. The range of the Swivel Screw Jacks are 4" to 16<sup>3</sup>/<sub>4</sub>" or 4" to 23<sup>3</sup>/<sub>4</sub>" when used in this application. Jacks and tubes must be perpendicular to soffit. The maximum swivel is 35° to vertical in a soffit application.

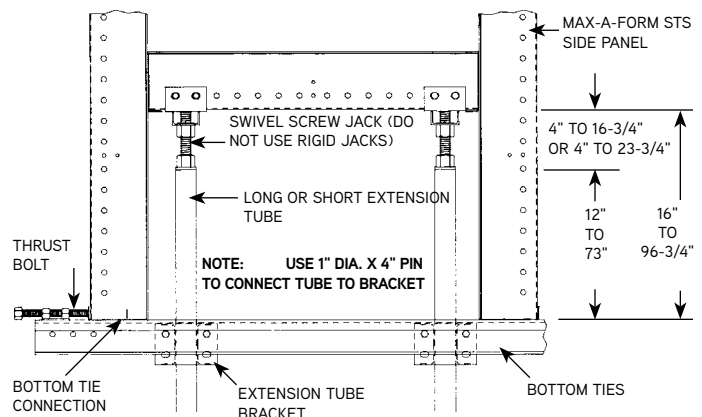

### D. Stability Beams

Stability Beams are available in 12' and 20' lengths. They are used in conjunction with the Pier Cap Brace to keep the forms properly aligned. The beams may be attached below the forms or above depending upon job conditions or preferences. Clip Angles are required if the beam is to be bolted to the soffit panel. A Thrust Bolt is required when the beam is bolted to the side panels. In the latter application the beam can take the place of a tie.

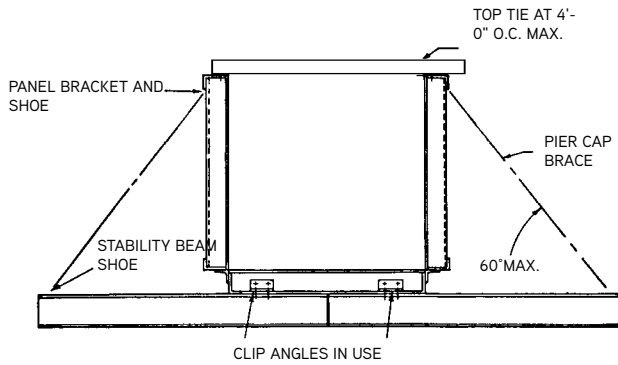

**Stability Beam attached to Soffit**

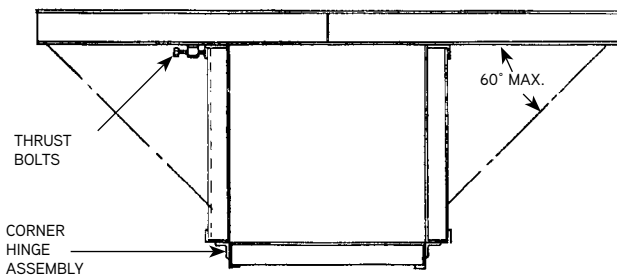

**Stability Beam attached to Side Panels**

Flat soffits may be hinged if desired. When using the Column Hinge Assembly the Stability Beams should be located over the top of the side panels.

### E. Support Devices

Two standard support mechanisms are offered for affixing Max-A-Form STS self-spanning gangs to their supporting columns or similar structures: friction type supports and anchor type supports.

1. Friction type support: Friction Collars are used for this purpose. These collars are meant for round or rectangular column applications and eliminate the anchor requirements.
  - a. The round collars consist of two semi-circular steel bands with mountings for 70K jacks and Walkway Mounts. The jacks provide elevation adjustments for stripping capabilities. The Circular Friction Collar is rated at 96K total (48K each side) up to and including the 36" diameter size. Allowable working loads are reduced for larger diameters. A Friction Collar requires four bolts, four washers, and four nuts. The bolts and nuts should be lightly oiled and tensioned per Symons specifications.

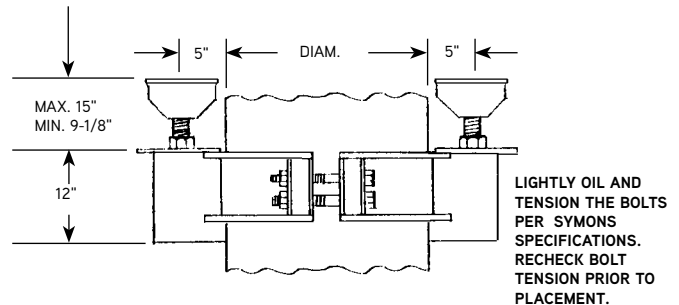
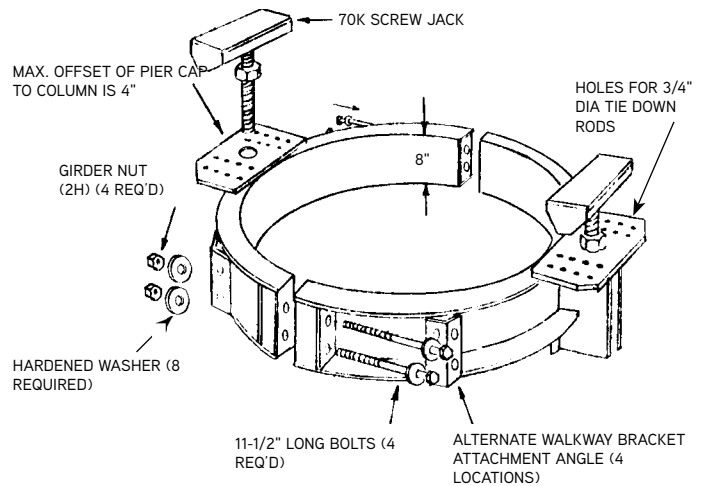

**Circular Friction Collar**

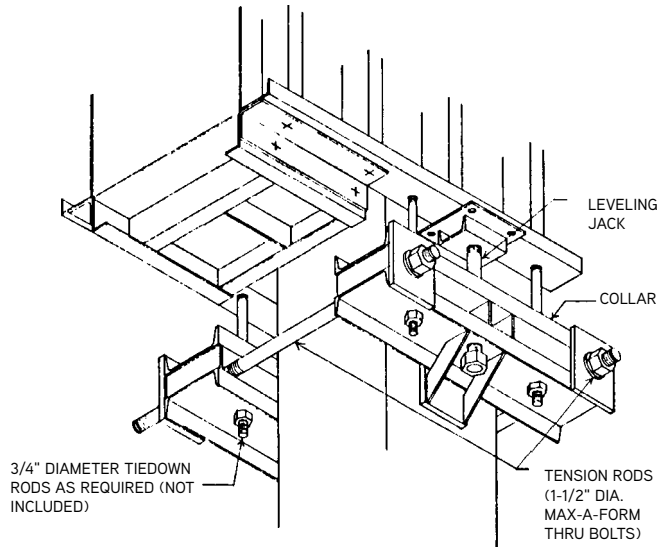

### 20 KIP Square Friction Collar

- b. The 20 KIP (10 KIPS per side) square friction collar can be used on square or rectangular columns. The width of the column is limited from 12" to 24" (the face that the collar bears against) but length is variable. Minimum concrete strength is 3,000 psi.

Tension 1½" diameter Tension Rods per Symons specifications.

Maximum loading = 10 KIPS per side at 3:1 safety factor. Collar must be loaded directly over the screw jack bearing pads.

To calculate the length of the 1½" diameter tension rods, add dimension "L" plus 24 inches. 1½" diameter tension rods are Max-A-Form STS thru bolts.

No side load permitted on leveling jacks.

**Caution:** Do not attach Friction Collars to steel, light-weight concrete or any surface other than standard weight concrete. The Friction Collar to concrete contact surface must be free of any oil or compound that will affect the safe usage of this product.

**Caution:** Friction Collar bolts are to be used only on the job (project) they were supplied for. Do not reuse on later projects. Never use bolts and nuts that do not turn freely for the full thread length.

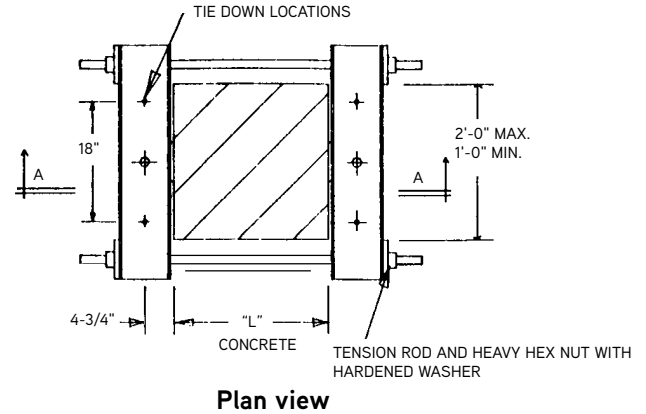

Lightly oil threaded rods and tension them per Symons by Dayton Superior Specifications. Recheck tension prior to placement.

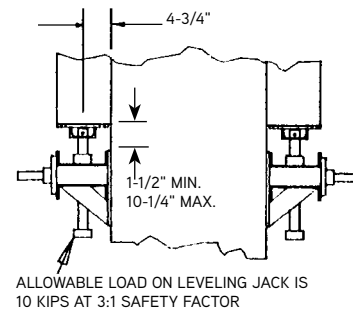

2. Anchor type support:

Several types of devices are available for this purpose, based on capacity requirements. Most common for self-spanning applications are the Anchor Clamps, 70K Screw Jack, and 140K Screw Jack.

- a. The Anchor Clamp will safely support 25,000 pounds at a 2:1 safety factor. It requires a 1½" diameter anchor bolt or thru rod and a 5" x 7" x 7/8" flat washer. The bolt or rod should be a minimum distance of 6" from the top of the previous pour. The anchor clamp is 21 7/8" long and has an adjustment range of 12 inches.
- b. The Adjustable Anchor Clamp is also rated at 25,000 pounds at 2:1 safety factor, but has more adjustment. It is 35" long and has an adjustment range of 22 13/16". Anchor bolt and washer sizes are the same as required for the anchor clamp.

**Caution:** Forms must always be tied or bolted down to supporting device.

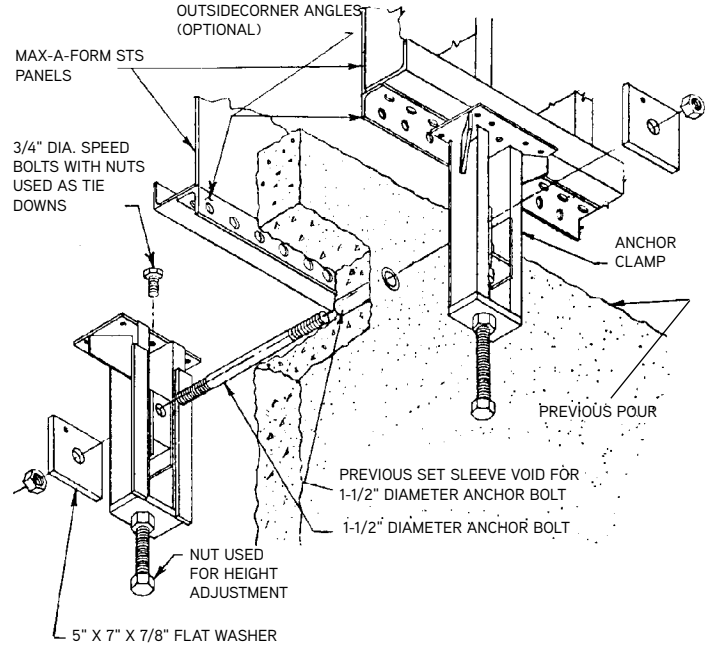

- c. The 70K 3 Position Anchor Bracket consists of two major pieces: the 70K Anchor Bracket and 70K Screw Jack. The 3 position bracket allows the Max-A-Form STS panel to be offset by as much as 8" from the column or pier. The bracket is fastened to the concrete with two 1½" diameter bolts. The jack has a swivel head for sloping conditions and adjusts from 10" to 15" above the top of the anchor brackets.

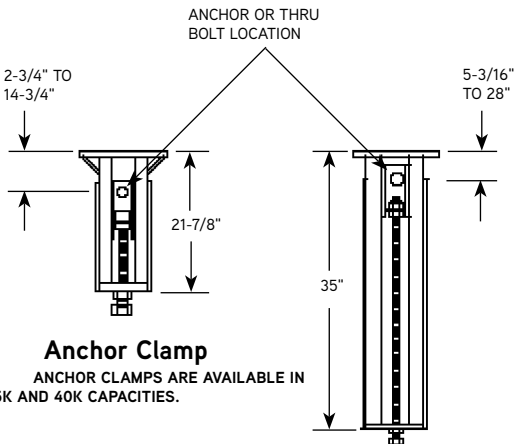

NOTE: ANCHOR CLAMPS ARE AVAILABLE IN 12K, 25K AND 40K CAPACITIES.

**Adjustable Anchor Clamp**

d. The 140K Anchor Brackets are also a two piece system, and the bracket comes in single and two-position models. They both require two 2" diameter bolts and the adjustment range of the 140K Screw Jack is 12" to 18" above the bracket. The one position bracket allows up to a 2" form offset and the two position bracket allows from a 2" offset up to an 8" offset.

For all jacks, the loads must be framed into the jack in such a manner that only vertical axial loads are transmitted. Shims and special brackets should only be used if all prying and shear forces are adequately resisted. Please check with your representative on these types of conditions.

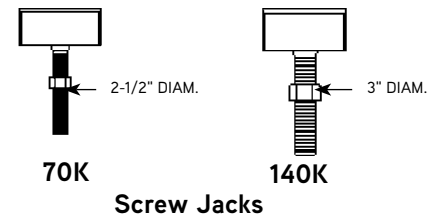

**Note:** 70K denotes 70,000 pounds allowable capacity at 2:1 safety factor. 140K denotes 140,000 pounds allowable capacity at 2:1 safety factor.

**Caution:** A Spreader Beam is required to develop full capacity of the Anchor Brackets.

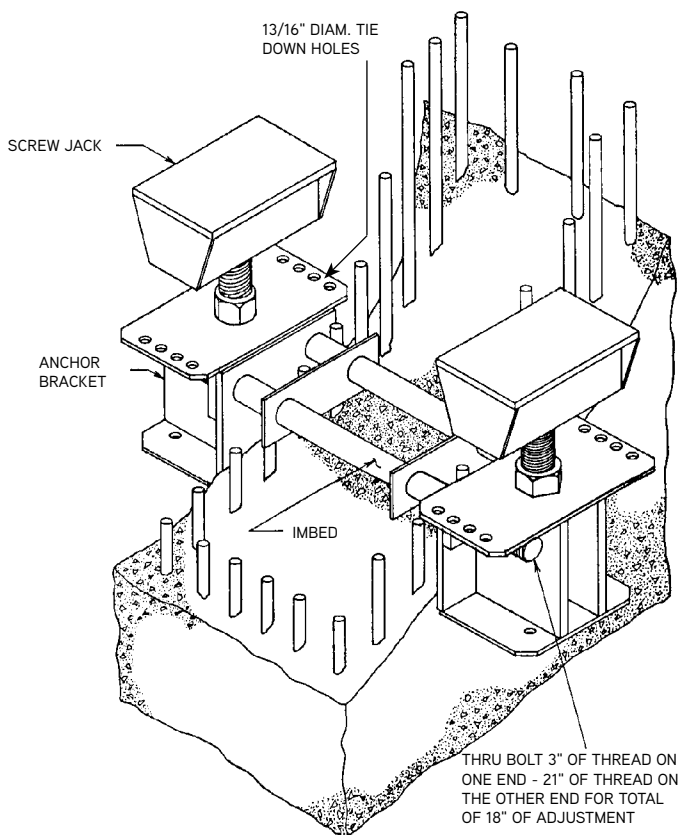

ANCHOR BRACKET	HOLE USED	RANGE
70K THREE POSITION	1ST	0" - 2"
	2ND	2" - 5"
	3RD	5" - 8"
140K ONE POSITION		0" - 2"
140K TWO POSITION	1ST	2" - 4-1/2"
	2ND	4-1/2" - 8"

**Note:** Bolt Outside Corner Angle to spreader, and spreader to Max-A-Form STS panel prior to setting form on bracket

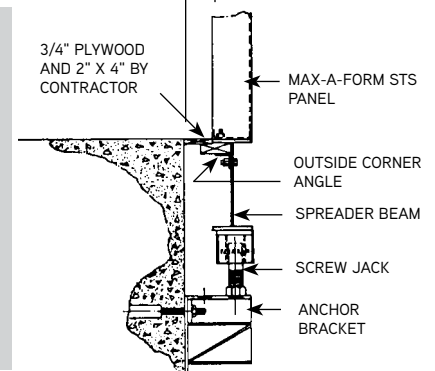

Section at Pier

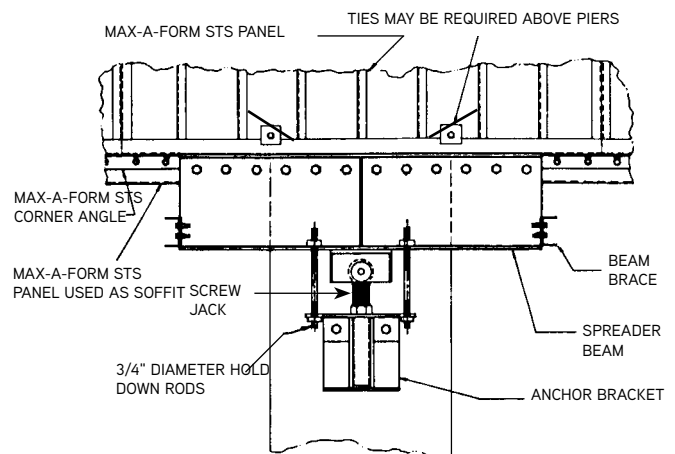
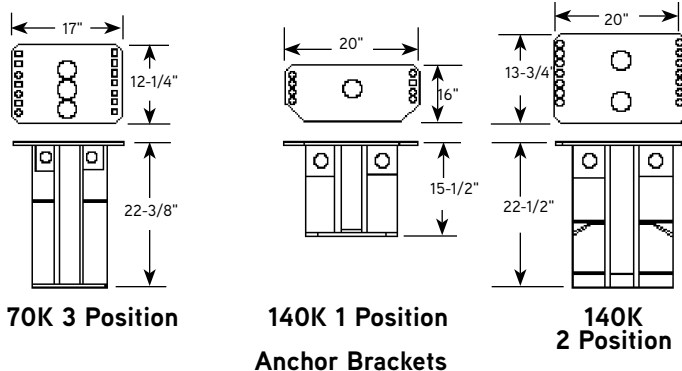

3. The 300K Support System is designed with the heavy civil construction market in mind. With a safe working load of 300,000 lbs per bracket, this system has the highest support capacity in the market. The 300K Support System has multiple standard accessories which add versatility for different job requirements.

**NOTE:** Dayton Superior Engineering should be involved in the design and application of the 300K Support System.

### 300K Support Bracket

Description	Product Code	Weight
300K Support Bracket	F1408000	1,610 lbs

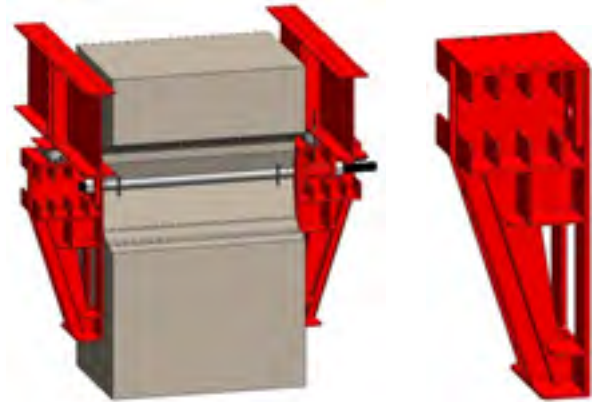

300K Support Bracket

### 300K Sand Jack Assembly

The extreme loads exerted on the 300K System can make stripping a challenge. The 300K Sand Jack Assembly helps facilitate a safe and cost effective load release. The assembly comes as one unit, consisting of a Top and Bottom sub-assembly. The Sand Jack is fastened between the Bracket and the Spreader Beam.

Description	Product Code	Weight
300K Sand Jack Assembly	F1408150	188 lbs
300K Sand Jack (Top)	F1408100	47 lbs
300K Sand Jack (Bottom)	F1408105	140 lbs

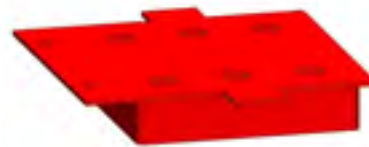

300K Sand Jack (Top)



300K Sand Jack (Bottom)

### Steel Shim Pack Kit

Dayton Superior offers a standard set of steel shims for purchase. The shims are 15" x 15" square and the kit includes one of each thickness; 1/2", 1/4", and 10 Gauge.

Description	Product Code	Weight
Steel Shim Pack Kit	F1408900	73 lbs



Steel Shim Pack Kit

### Spreader Beam

As with other support options, the 300K Support System requires proper transfer of loads from the bracket to the MAF STS panel(s). The 300K Spreader Beam is designed specifically for this purpose.

Description	Product Code	Weight
300K Spreader Beam	F1408200	951 lbs



Spreader Beam

### 300K Column Adapters

When placing a support bracket on a round column or surface, achieving proper surface contact can be a challenge. Dayton Superior offers a standard, rentable solution called Column Adapters. These parts come in three standard sizes accommodating a range of radii and are simple bolted on to the 300K Bracket.

Description	Product Code	Weight
9' - 11' 300K Column Adapters	F1408300	1,277 lbs
7' - 9' 300K Column Adapters	F1408310	1,270 lbs
6' - 7' 300K Column Adapters	F1408320	1,263 lbs

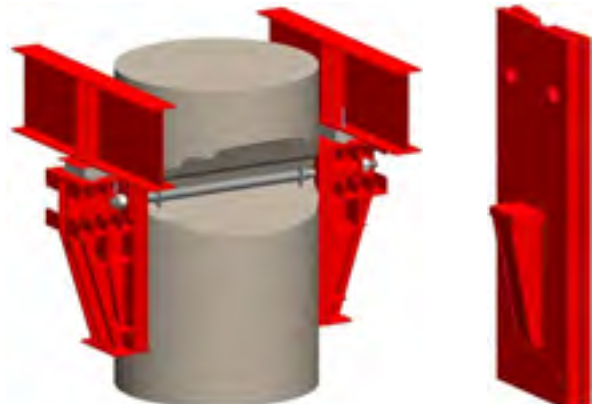

300K Column Adapters



### 300K 3" Diameter Thru Bolts

The Thru Bolt for the 300K Support System is 3" in diameter and come in three standard lengths.

Description	Product Code	Weight
Thru Bolt x 14'	F1408520	352 lbs
Thru Bolt x 12'	F1408500	304 lbs
Thru Bolt x 8'-10"	F1408520	228 lbs
3" Diameter Heavy Hex Nut	F47914	9.50 lbs



300K 3" Diameter Thru Bolt

### 300K Thru Bolt Sleeves

The Thru Bolt Sleeves slide over the Thru Bolts eliminating the need to run a nut down feet of the bolt at a time, creating a safe and more efficient method of securing the 300K Bracket.



300K Thru Bolt Sleeve

Description	Product Code	Weight
300K Thru Bolt Sleeve x 3'	F1408430	70 lbs
300K Thru Bolt Sleeve x 2'	F1408420	55 lbs
300K Thru Bolt Sleeve x 1'	F1408400	40 lbs
300K Thru Bolt Sleeve x 6"	F1408410	25 lbs

### 300K Imbed Tubes

Imbeds are installed in the supporting concrete before it's poured. An imbed acts as a sleeve or guide for the Thru Bolts. They are usually secured to the rebar or form to prevent movement. Lengths can be cut to lengths of 1" increments. Standard lengths are below:



300K Imbed Tubes

Description	Product Code	Weight
12' Length - 300K Imbed	F1408910	72 lbs
8' Length - 300K Imbed	F1408920	52 lbs
6' Length - 300K Imbed	F1408930	41 lbs

### 300K Plastic Imbed Cap

Description	Product Code	Weight
300K Plastic Imbed Cap	F150636C19	0.15 lbs



300K Plastic Imbed Cap

**NOTE:** It is critical Imbed Tubes and Thru Bolts are installed level.

**F. Spreader Beams**

Although the anchor brackets can support 70K and 140K respectively, the Max-A-Form STS panel cannot transfer those loads without the use of Spreader Beams. If the load to be transferred from the panel to the bracket exceeds 25,000 pounds, then a spreader beam may be required. Check with your Symons representative for actual load limitations on different size panels.

Two size Spreader Beams are available. The 70K beam is 3'-0" long and 8" deep. The 150K beam is 5'-11½" long and 19½" deep. A Beam Brace is to be used at either end of the Spreader Beams for added stability. It attaches with ¾" bolts and nuts. Spreader Beams must be bolted to panels and tied down to anchor brackets.

**G. Thru Bolts and Imbeds**

Imbeds are installed in the supporting concrete before it's poured. An imbed acts as a sleeve or guide for the necessary thru bolts. They are usually secured to the rebar or form to prevent movement.

IMBED	LENGTH	W
25K	1'-0" TO 9'-0"	—
70K	1'-0" TO 9'-0"	7"
140K	1'-0" TO 9'-0"	10"

NOTE: IMBED LENGTHS ARE LISTED (I.E. 9'-0", 8'-0", ETC.) ARE CONCRETE DIMENSIONS. IMBEDS ARE HELD BACK 2" AT EACH END. 9'-0" IMBED IS 8'-8" ETC.

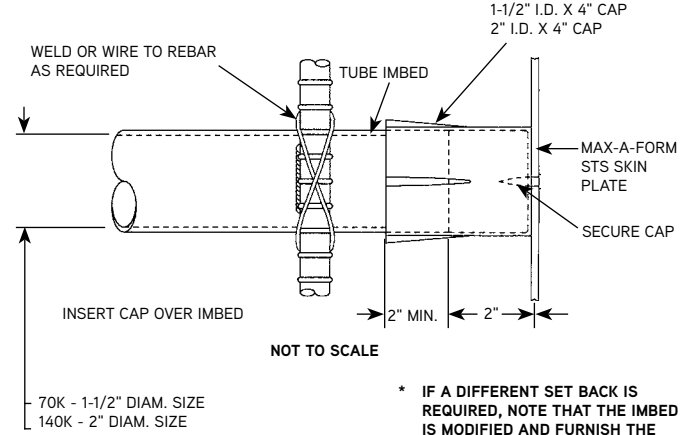

**Section Imbed and Cap During Pour**

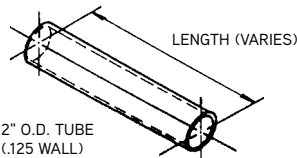

**25 KIP Imbeds**

NOTE: IT IS CRITICAL THAT THE IMBED AND THRU BOLTS ARE INSTALLED LEVEL.

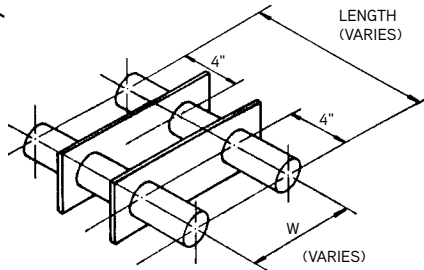

**70 and 140 KIP Imbeds**

LENGTH VARIES FROM 1'-0" TO 9'-0" IN 1'-0" INCREMENTS

NOTE: THRU BOLTS CAPABLE OF 18" OF ADJUSTMENT

BOLT DIA.	CAPACITY	LENGTH*
1½"	25K & 70K	2'-6" TO 10'-6"
2"	140	2'-8" TO 10'-8"

\*LENGTHS VARY IN 1'-0" INCREMENTS

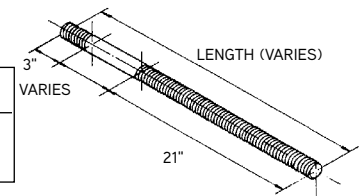

**Thru-Bolts with Nuts**

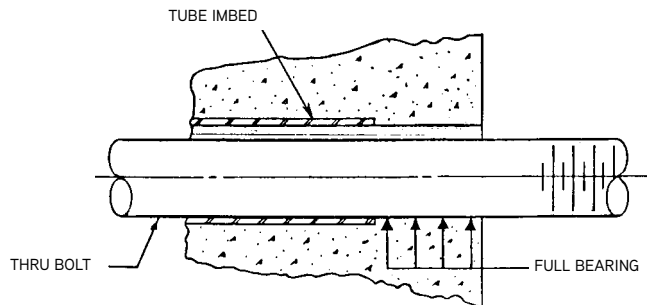

**Section - Thru-Bolt Inserted**

## H. Installation Sequence: Imbeds and Jacks

First, determine the location of jacks and thru bolts. Refer to the layout drawings.

Next, fasten the Imbeds to the rebar such that the two pipes are horizontal along their axes and to each other.

Cap the ends of the Imbeds to prevent concrete blockage. Secure the caps to the formwork, for ease of removal, with a screw.

After the forms are stripped, insert the Thru Bolts and mount the Anchor Bracket. Install washers and nuts to both sides. Adjust the jack elevation to the desired level, and ready the Max-A-Form STS.

## I. Placing Gangs

### 1. Lifting

Position the lift brackets on the Max-A-Form STS gang so it lifts plumb and level, and does not exceed lift bracket capacity. Use a lift beam to distribute lifting forces into the Max-A-Form STS panels in the most efficient manner i.e. vertical loading.

After all the crane cable connections are made, lift the Max-A-Form STS unit off the staging area about two (2) feet and verify that the formwork is hanging plumb and straight. If any problems are evident, such as racking or bending, lower the unit to the staging area and modify the lift arrangements.

Box units, often used for pier cap construction, usually require spreaders and bracing to maintain the desired shape. "L" shaped gangs (side + soffit) may require counter weights for level lifting.

### 2. Form placement

Wall forms: Set the form on the previously installed support equipment. Lap the previous pour approximately two inches. While the crane is holding the form, secure the formwork to the support system and/or to the previous pour. Tie downs,  $\frac{3}{4}$ " rods that hold the formwork to the support brackets, should be installed at each support when the formwork is subjected to uplift and/or rotational forces. The contractor can use clamping devices or other methods to secure the desired alignment. Brace the wall form before removing the crane rigging, using H.D. wall braces, Pier Cap Braces, and guy wires as required.

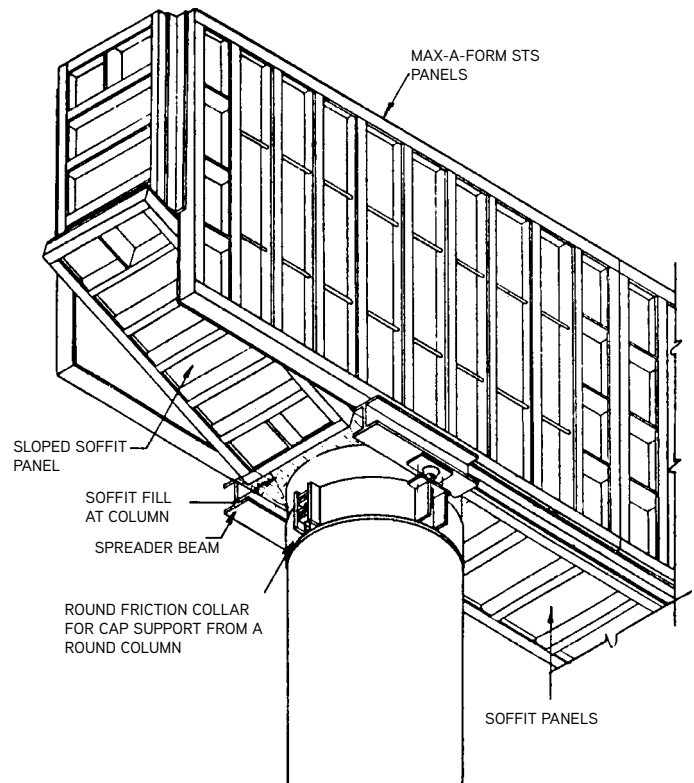
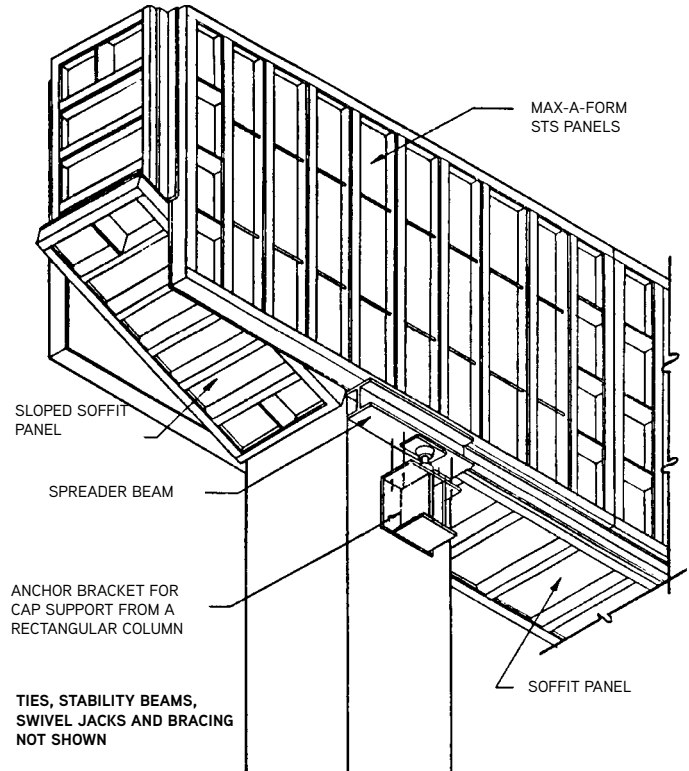

3. Pier cap: The best way to set a Max-A-Form STS pier cap is as a unit. First, the entire "box" is lifted and positioned over the pier stem(s). Then, set the unit onto the support devices. Next, secure the previously attached Spreader Beam to the support bracket with  $\frac{3}{4}$ " tie down rods. If the pier stem can be lapped by the Max-A-Form STS, then the forms can be drawn tightly to the pier or blocked off it. When the formwork is secured to the pier stem supporting system, then the crane rigging can be removed.

Any large cantilevers or other severe loadings should be stabilized with knee bracing and/or guy wires. The contractor must secure all formwork to the supporting devices and to near by fixed structures to prevent movement before, during and after the concrete pour(s).

## J. Stripping

1. Wall forms and multi-lift

Attach the crane rigging to the lifting brackets and take up the slack. Loosen and remove all ties. Break the bond between the concrete and the forms. Do not use the crane to break the bond. The gang is then raised and carried to the next location.

2. "L + I" Shape Stripping Method

This stripping method is usually applied to a concrete bent, which has a minimum of two (2) columns and a uniform depth between the columns, having a rectangular cross-section. It is strongly recommended to plan ahead how to strip the form, since the stripping method influences both the design scheme and the assembling sequence. Therefore the assembling sequence will be included as a part of a stripping operation. The "L + I" stripping method implies that the cross section of the formwork has a "U" shape and it will be stripped into two panels one as an "L" shape and the other part as a "I" shape.

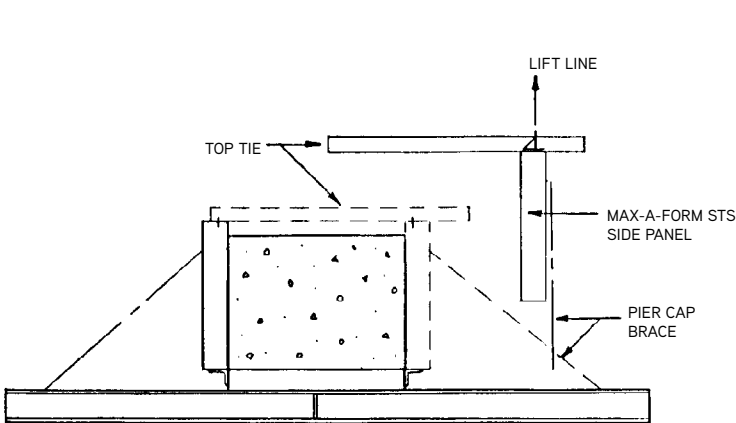

"I" Section Pick  
("L" Section supported by Screw Jacks)

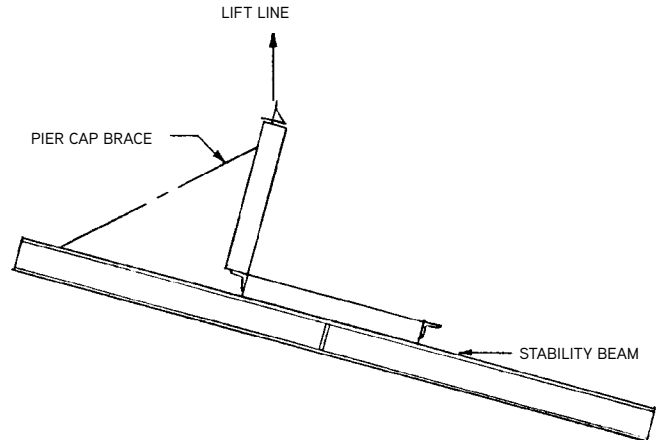

"L" Section - 2nd Pick

a. Assembling and Setting the Forms

- 1) Select and prepare the assembly site, which should have easy access to a crane and a reasonably flat surface. Place at least 12" high blocks approximately at 6 foot intervals and level up the top.
- 2) Place the soffit panels face down and connect the outside corner angles to the soffit panels as shown on the layout drawing. Unless noted otherwise on the drawing, the bolt connection is usually 12" on center. Attach the Stability Beams to the soffit panels using the Clip Angles at the locations indicated. While connecting the beams to the soffit, be sure that the ends of the beams are aligned and the Thrust Bolts are all on one side of the soffit, which side will be stripped first as an "I" section.
- 3) Flip over the soffit assembly (now face up) and place them according to the layout drawing. Make sure all the dimensions and panel sizes are in agreement with the drawing including the gaps around the column area and the forms are properly aligned along the length of the bent.
- 4) Start with the one side of the side forms by putting a side panel on top of the outside corner angles and place temporary braces as needed to hold in place. Connect the side panel to the soffit forms with bolts finger-tight at this time. Place the next side panel and connect it to the previous side panel using only the round holes between them. Insert the Girder Bolts at both top and bottom of the panel joint, and connect the side panel to the soffit as before. Continue this step as many as needed for one complete side.
- 5) Attach the Pier Cap Braces between the Stability Beams and the side panels erected. Tighten the bolt connection once the entire side is aligned properly. The Girder Bolts need not to be torqued.
- 6) If the rebar cage is to be flown with the form, then place the rebar cage at this time using the proper spacers around as required.
- 7) Attach the other side of the side forms, in a similar way to the procedure described in step 4 above. In addition to the step, the Top Ties need to be installed at the locations shown on the drawing, which will eliminate the necessity of the temporary braces. However, if the rebar cage is not to be flown with the form, it is recommended to install the minimum amount of the top ties since they have to be removed after setting on the final position to put the rebars into.

8) Attach the Pier Cap Braces and tighten the connections once the forms are all aligned. Connect the rebar cage to the Top Ties, if the rebar cage has already been placed.

9) Attach the Spreader Beams, if required, and the Top Tie/Lift Brackets as indicated on the drawing. Be sure the gusset plate of the beam falls into the supporting jack location.

10) Attach the necessary accessories such as Walkway Brackets.

11) Before setting the forms in place, it is necessary to install the supporting jacks and brackets on the columns at the elevations indicated on the drawing. Finer adjustment can be achieved by the Screw Jacks.

12) Lift the form assembly and move slowly to the position. Once the form sits on the final position, install  $\frac{3}{4}$ " rods between the side panel and the supporting bracket to resist the uplift force due to wind while the crane is holding the form assembly.

13) Disconnect the Top Ties as required to put the rebars into the form, if the rebar was not installed earlier. Proper spacers are required around. Reconnect the Top Ties.

14) Inspect the forms and dimensions again before pouring. Be sure the job built forms around columns are sufficiently strong enough.

b. Stripping the Form

1) Connect the crane cables to the lifting brackets on the "I" section side and remove any internal ties. Unscrew the Thrust Bolts and disconnect the Stability Beams on this side. Disconnect the Top Ties from the other side panels. This means that the "I" section side will fly with the Top Ties and the Pier Cap Braces. Unbolt the connection between the Outside Corner Angle and the side panels. Remove the  $\frac{3}{4}$ " diameter rods used as tie downs to the anchor bracket. Strip the "I" section side slowly.

2) Connect the crane cables to the lifting brackets on the remaining side panels. Lower down the supporting jacks to release the soffit forms from the concrete and disconnect the tie downs. It may be necessary to strip the job built forms around columns first to facilitate the stripping. Strip the "L" section form with the Pier Cap Braces and the Stability Beams intact. Due to the center of gravity point, the soffit will not fly horizontally. Counterweight on the walkways may be used to compensate this effect.

- 3) Remove the supporting jacks and brackets from the columns and install them for the next bent to be formed.

**K. Hammerhead Stripping**

This stripping method is used on hammerheads or pier caps supported by only one column or pier. The forms are disconnected at a vertical joint and stripped in two "U" sections. The two halves are cleaned and reconnected on the ground, and then flown to the next pour position.

**1. Assembling**

To assemble and set the forms refer to the procedure described in section A of "L & I" Stripping Method in previous section (J. Stripping).

**2. Stripping**

- a. Install blocks between top of pier cap and the top ties on the left side forms.
- b. Connect crane cables to the lifting brackets on the right side forms.
- c. Remove all internal and top ties on right side half. Unbolt vertical joint connecting left and right halves. Remove tie downs from anchor brackets supporting right side forms and lower the screw jacks supporting right side forms and lower the screw jacks. The weight of the forms should break the bond with the concrete. If not separate forms slightly by jacking between top tie lift brackets.
- d. Strip the right hand side U-shape (2 side forms and soffit) and lower to ground.
- e. Repeat steps 2 through 4 for the left side forms.
- f. Clean, oil and reassemble forms on ground. Set rebar cage and fly to next pour.

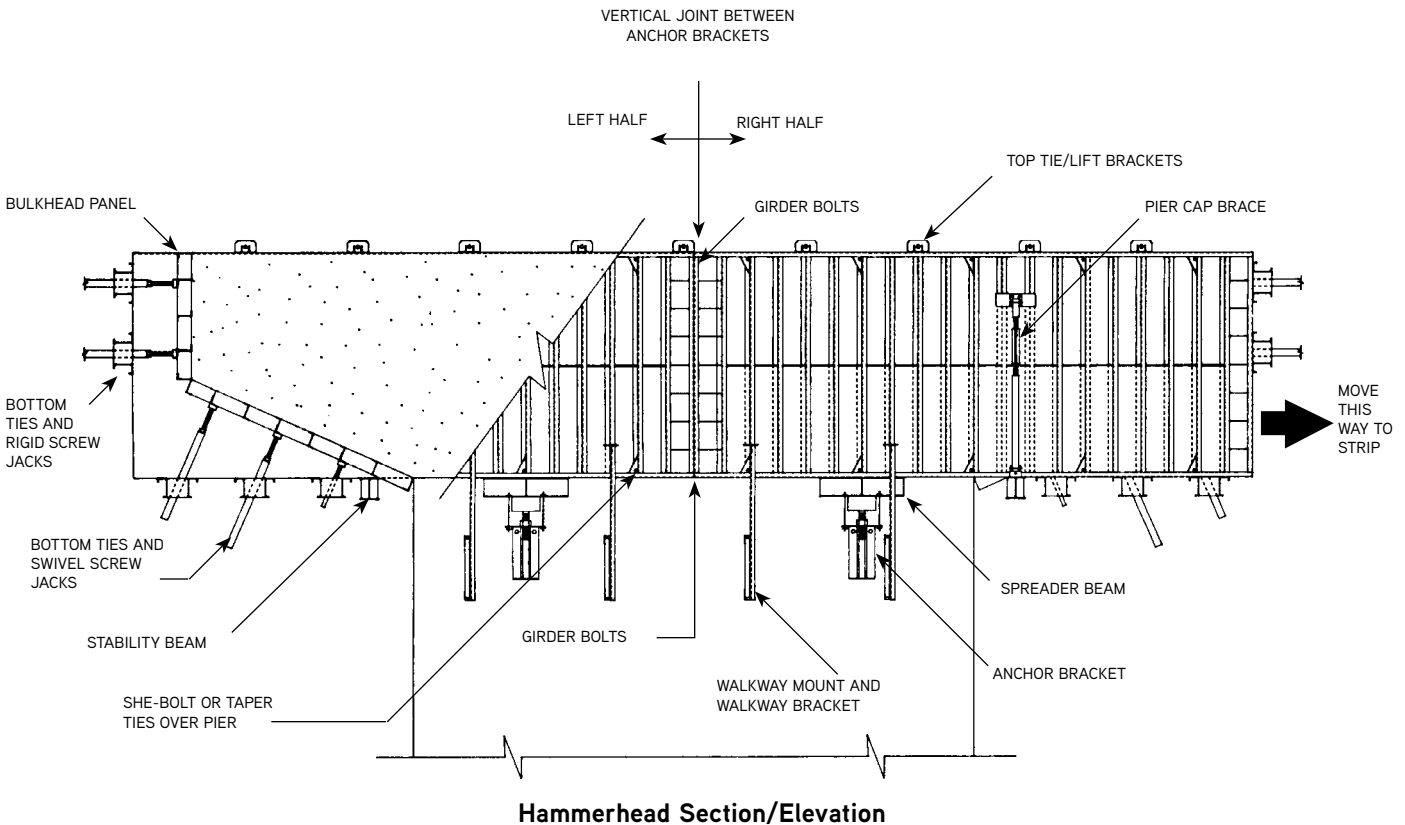

## L. Hinged Soffit Stripping

Forms used in self-spanning applications may be stripped as one unit if a hinged soffit is used. This method uses the Stability Beams over the top of the forms and no Bottom Ties. The soffit panels act as the bottom ties. The soffits must not be inset or sloped. Once the forms are assembled they are lowered over the rebar cage either on saw horses on the ground or on top of the pier.

### 1. Assembly and Setting the Form

- a. Select and prepare the assembly site, which should have easy access to a crane and a reasonably flat surface. Place 2x lumber at soffit panel joints and ends.
- b. Place the soffit panels face down and connect the outside corner angles to the soffit panels as shown on the layout drawing. Unless noted otherwise on the drawing, the bolt connection is usually 12" on center. Attach the Heavy Duty Hinge Assemblies to the soffit panels opposite the Outside Corner Angles.
- c. Flip over the soffit assembly (now face up) and place them according to the layout drawing. Make sure all the dimensions and panel sizes are in agreement with the drawing including the gaps around the column area and the forms are properly aligned along the length of the bent. Soffit swing down clearance between column, pier, friction collar or anchor bracket should be at least 6".

- d. Start with the side forms by putting a side panel on top of the outside corner angles and place temporary braces as needed to hold in place. Connect the side panel to the soffit forms with bolts finger tight at this time. Place the next side panel and connect it to the previous side panel using only the round holes between them. Insert the Girder Bolts at both top and bottom of the panel joint, and connect the side panel in the soffit as before. Continue this step for as many as needed for one complete side.

- e. Attach the opposite side panels in a similar fashion to the Corner Hinge Assembly. Blocking under the panels may be required to prevent hinging during assembly.

Install the Stability Beams over the top and attach Pier Cap Braces (on both sides) as assembly proceeds.

- f. Install Top Ties and bulkheads. Temporary bracing may be removed.

- g. If rebar cage is to be flown with form, oil forms at this time, attach lifting rig to Top Tie/Lift Brackets. Unbolt Outside Corner Angles from side panels. Lift forms and lower over rebar cage. Cage should be blocked up at column locations, to allow soffits to be swung up and hang down walkways to be attached.

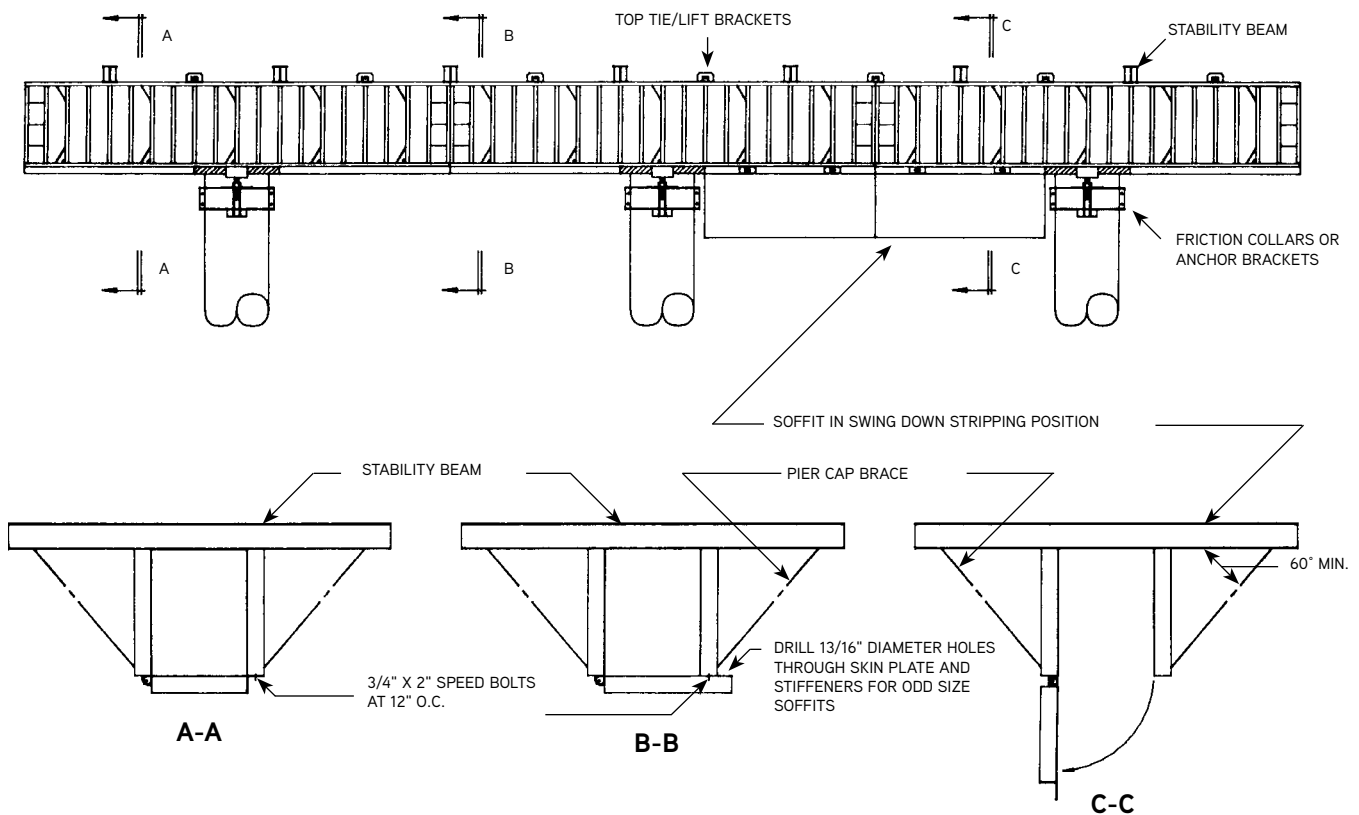



- h. Bolt up soffit and secure rebar in forms. Attach Walkway Mounts and Brackets.
- i. Before setting the forms in place, it is necessary to install the supporting jacks and brackets on the columns at the elevations indicated on the drawing. Finer adjustment can be achieved by the Screw Jacks.
- j. Lift the form assembly and move slowly to the position. Once the form sits on the final position, install  $\frac{3}{4}$ " rods between the side panel and the supporting bracket to resist the uplift force due to wind while the crane is holding the form assembly.
- k. Install job built forms around columns. Inspect the forms and dimensions again before pouring. Be sure the job built forms are sufficiently strong enough.

## 2. Stripping the Form

- a. Unbolt the Outside Corner Angles from the side panels. Use the crane or a come along to prevent the soffit from swinging down suddenly.
- b. Loosen (but do not remove) the following connections; both sides of the Stability Beams, Top Ties and bulkheads. Any internal ties, box out supports, anchor setting bolts and anything else imbedded in the concrete should be removed from the side panels.
- c. Remove job built fillers from around columns.
- d. Attach crane rigging and remove tie downs. Shorten the Pier Cap Braces to pull the panels away from the concrete pier cap and break the bond.
- e. Attach tag lines to all four corners. Slowly raise the forms carefully sliding it away from the pier cap. Lower it away from the pier cap. Lower to ground for cleaning and application of release agent. Stability Beams, Top Ties, Pier Cap Braces and bulkheads should all be repositioned and bolts tightened at this time.
- f. If rebar is set on piers for the next pour, lower form over rebar cage onto Friction Collar or Anchor Bracket Jacks. Install tie downs and swing up soffit panels. Plumb forms and tighten all bolts before releasing crane. Install job built fillers, inspect forms and dimensions again before pouring.
- g. If rebar cage is to be installed on the ground then proceed from step 7 in the assembly section.

20 KIP Square Friction Collar.....	23	Thru Bolts .....	28
70K 3 Position Anchor Bracket .....	24	Tie Installation .....	4
85K She-Bolts .....	4	Tie Obstructions .....	18
96K Batter Washer .....	4	Tools.....	7
96K Taper Ties .....	4	Top Tie .....	5
140K Anchor Brackets .....	25	Versiform Waler .....	10
Adjustable Anchor Clamp .....	24	Waler Attachment Bracket .....	10
Alternate Walkway Bracket .....	9	Walers .....	11
Anchor Brackets.....	25	Walkway Mount.....	9
Anchor Clamp.....	24	Wall Ties.....	3
Anchor type support.....	24	Wide Walkway Brackets .....	8
Battered Walls.....	14		
Batter Plate Castings.....	4		
Bottom Tie .....	5		
Bottom Ties.....	21		
Bulkheads .....	14		
Cast-Contour .....	4		
Circular Friction Collar .....	22		
Column Form .....	12		
Columns .....	16		
Corners .....	15		
Extension Tubes .....	21		
Friction type support .....	22		
Gang Care .....	13		
Gang Placement .....	13		
Hammerhead Stripping.....	32		
Hammering Caps.....	4		
Handling Hook .....	7		
Hinged Soffit Stripping.....	33		
Imbeds.....	28		
Job-Built Fillers.....	14		
Ladder .....	6		
Lift Bracket .....	5		
Max-A-Brace.....	12		
Outside Corner Bracket.....	12		
Pier Cap Brace .....	11		
Pipe Form Aligner .....	10		
Pipe Form Aligner Shoe.....	11		
Placing Gangs.....	29		
Position Anchor Bracket .....	24		
Raised Form .....	18		
Rigid Screw Jacks.....	21		
Self-Spanning .....	19		
She-Bolt Ties.....	3		
Soffit Support .....	21		
Speed Bolts.....	2		
Spreader Beams.....	28		
Stability Beams.....	22		
Stripping.....	30		
Super She-Bolt.....	3		
Super Taper Tie.....	3		
Support Devices .....	22		
Swivel Screw Jacks.....	21		
Taper Tie Hammering Caps .....	4		
Taper Ties .....	3		

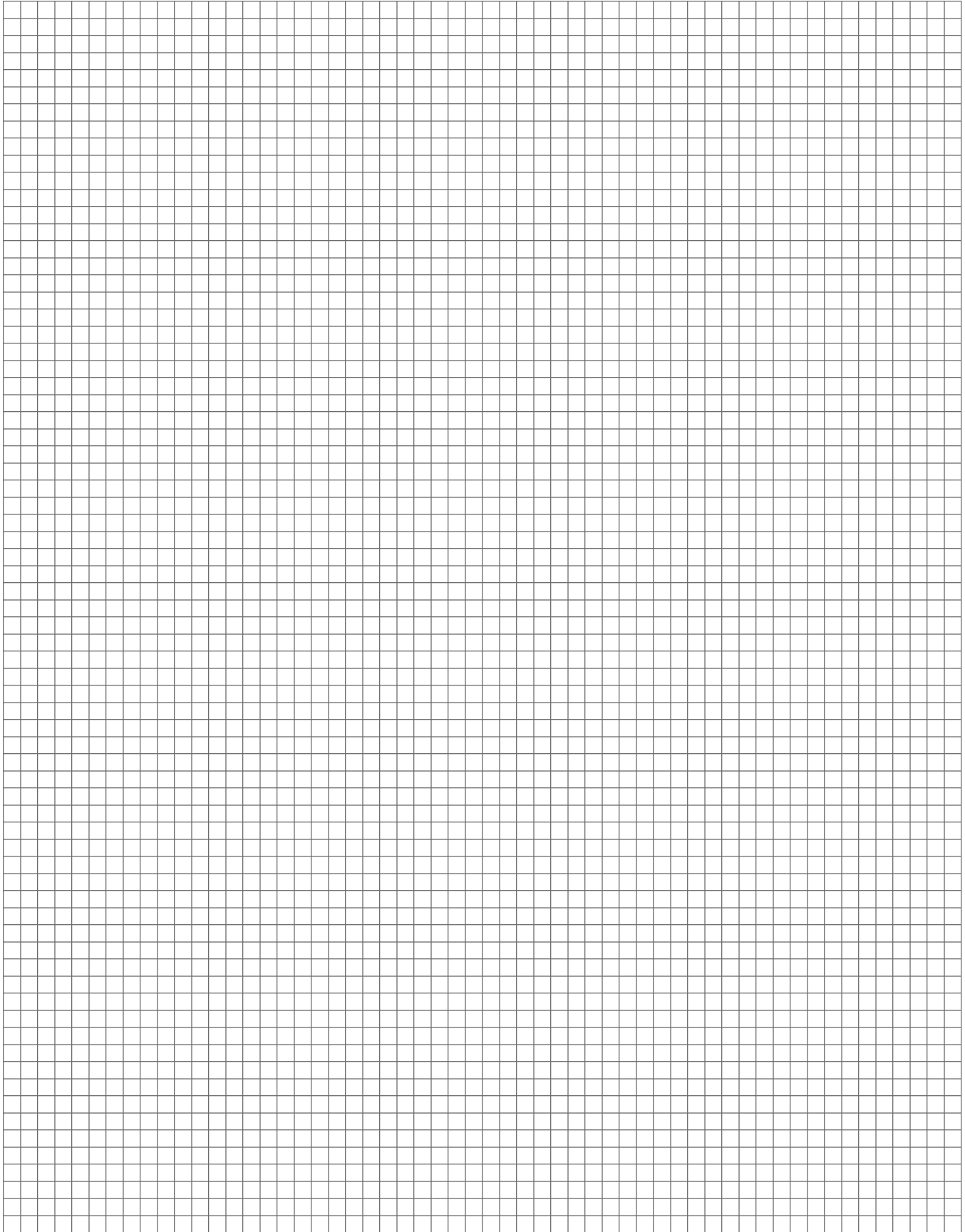

	<div data-bbox="544 210 1448 331" style="background-color: red; color: white; padding: 5px;"> <b>WARNING</b></div> <p data-bbox="609 369 1390 443" style="text-align: center;"><b>Improper Use of Concrete Forms and Shores Can Cause Severe Injury or Death</b></p> <p data-bbox="576 451 1422 558">Read, understand and follow the information and instructions in this publication before using any of the Dayton Superior concrete accessories displayed herein. When in doubt about the proper use or installation of any Dayton Superior concrete accessory, immediately contact the nearest Dayton Superior Service Center or Technical Service Department for clarification.</p>
---	---

Dayton Superior products are intended for use by trained, qualified and experienced workmen only. Misuse or lack of supervision and/or inspection can contribute to serious accidents or deaths. Any application other than those shown in this publication should be carefully tested before use.

The user of Dayton Superior products must evaluate the product application, determine the safe working load and control all field conditions to prevent applications of loads in excess of a product's safe working load. Safety factors shown in this publication are approximate minimum values. The data used to develop safe working loads for products displayed in this publication are a combination of actual testing and/or other industry sources. Recommended safe working loads given for the products in this publication must never be exceeded.

---

## Worn Working Parts

For safety, concrete forms must be properly used and maintained. Concrete products shown in this publication may be subject to wear, overloading, corrosion, deformation, intentional alteration and other factors that may affect the device's performance. All reusable products must be inspected regularly by the user to determine if they may be used at the rated safe working load or should be removed from service. The frequency of inspections depends upon factors such as (but not limited to) the amount of use, period of service and environment. It is the responsibility of the user to schedule inspections for wear and remove the hardware from service when wear is noted.

---

## Shop or Field Modification

Welding can compromise a product's safe working load value and cause hazardous situations. Knowledge of materials, heat treating and welding procedures is necessary for proper welding. Consult a local welding supply dealer for assistance in determining required welding procedures.

Since Dayton Superior cannot control workmanship or conditions in which modifications are done, Dayton Superior cannot be responsible for any

---

## Interchangeability

Many concrete products that Dayton Superior manufactures are designed as part of a system. Dayton Superior strongly discourages efforts to interchange products supplied by other manufacturers with components supplied by Dayton Superior. When used properly, and in accordance with published instructions, Dayton Superior products have proven to be among the best designed and safest in the industry. Used improperly or with incompatible components supplied by other manufacturers, Dayton Superior products or systems may be rendered unsafe.

---

## Installation

### WARNING

1. Dayton Superior Corporation products shall be installed and used only as indicated on the Dayton Superior Corporation installation guidelines and training materials.
2. Dayton Superior Corporation products must never be used for a purpose other than the purpose for which they were designed or in a manner that exceeds specific load ratings.
3. All instructions are to be completely followed to ensure proper and safe installation and performance
4. Any improper misuse, misapplication, installation, or other failure to follow Dayton Superior Corporation's instruction may cause product malfunction, property damage, serious bodily injury and death.

### THE CUSTOMER IS RESPONSIBLE FOR THE FOLLOWING:

1. Conformance to all governing codes
2. Use of appropriate industry standard hardware
3. The integrity of structures to which the products are attached, including their capability to safely accept the loads imposed, as evaluated by a qualified engineer.

### SAFETY INSTRUCTIONS:

All governing codes and regulations and those required by the job site must be observed. Always use appropriate safety equipment

---

## Design Changes

Dayton Superior reserves the right to change product designs, rated loads and product dimensions at any time without prior notice.

**Note: See Safety Notes and Safety Factor Information.**





**SYMONS**<sup>®</sup>

BY DAYTON SUPERIOR

1125 Byers Road  
Miamisburg, OH 45342  
937-866-0711  
800-800-7966  
[WWW.SYMONS.COM](http://WWW.SYMONS.COM)

**THE  
POWER  
OF RED**<sup>™</sup>

DS##  
REV. 03/23

Copyright © 2016 Dayton Superior Corporation, All Rights Reserved.