



**BUILDING
STRENGTH™**

**GUIDELINES FOR
HANDLING PRECAST
CONCRETE PIPE AND
UTILITY PRODUCTS**

**CONCRETE
CONSTRUCTION
PRODUCTS**



**DAYTON
SUPERIOR®**



Table of Contents

Safety Factors	1
P50 SL Universal Lifting Eye.....	2
Inspection and Maintenance	2
Lifting Eye Installation.....	3
How to Use the SL Universal Lifting Eye.....	3
How to Use the SL Universal Lifting Eye.....	4
Correct Method for Lifting and Placing Pipe.....	4
How to Use SL Universal Lifting Eye for Setting Concrete Pipe	5
Correct Method for Pulling Pipe Together	5
How to Handle and Set Concrete Box Sections	6
How to Handle and Set Concrete Box Sections, Continued	7
Correct Method for Pulling Box Sections Together	7

Safety Factors

The safety factor to be applied to a particular product is a variable, depending on the degree of hazard or risk involved in the application of that product. In precast concrete construction, various conditions can often increase the loading, as well as the degree of risk involved. Jerking of the crane during lifting, use of a crane not adequate for the job, bouncing of the precast element after it has been lifted, handling the element more than anticipated, transporting over rough road surfaces, etc. all have high risk factors. The user should increase safety factors to reduce these risks.

Dayton Superior recommends that the following minimum safety factors be used when determining a product's safe working load and that the provisions of OSHA (Occupational Safety and Health Administration Act, Part 1910) and American National Standards Institute (ANSI 10.9) be strictly followed when considering safety factors:

Safety Factor	Intended Use of Product
4 to 1	Inserts used for lifting and handling
5 to 1	Hardware used for lifting and handling

If a different safety factor is needed for any reason, a product's safe working load must be changed accordingly by the user. The following equation is used to increase or reduce a safe working load:

Note: Load must be applied simultaneous to all Swift Lift Anchors in order to safely lift product.

$$\frac{\text{SWL} \cdot \text{Published Factor of Safety}}{\text{Required Factor of Safety}} = \text{New SWL}$$

The following chart shows a simplified method for determining the increased loads that are transferred from the slings to the anchor when using multi-leg slings. As the fleet angle θ (Theta) increases, the sling load also increases, which applies additional load to the anchor.

Multiplication Factor "F": for Calculating Applied Load on Sling/SL Anchor with a Fleet Angle of θ					
θ	0°	30°	60°	90°	120°
"F"	1.00	1.04	1.16	1.42	2.00

- P = Actual weight of precast element including adhesion
- θ = Fleet angle
- F = Multiplication factor
- $P \times F$ = Effective weight of precast element
- $P_1 = P_2$ = Anchor load using 2-leg sling
- $P_1 = P_2$ = $P \times F / 2$ anchors

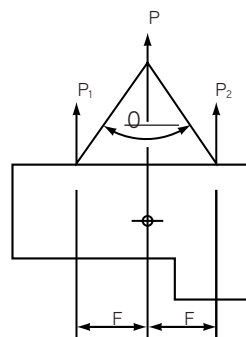

Warning: Use of a sling fleet angle greater than 120° is dangerous and must be avoided, it could overload the anchors and lead to premature failure.

It is recommended that for handling concrete pipe and utility products, the fleet angle be less than or equal to 60 degrees.

Note: The Precast/Prestressed Concrete Institute (PCI) states in its design handbook that deformed reinforcing steel members should not be used as handling devices for precast concrete elements.

P50 Swift Lift® Universal Lifting Eye

The Swift Lift Universal Lifting Eye (P50) consists of a flat-sided, spherical lifting body and a high strength bail. The lifting body has a T-shaped slot that permits rapid attachment and release of the head on Swift Lift Anchors.

The design of the P50 Universal Lifting Eye permits the bail to freely rotate 180°, while the complete lifting eye may rotate through a 360° arc. This design feature allows precast concrete elements to be turned, tilted and/or rotated under load.

Dayton Superior does not recommend the use of this lifting eye for edge lifting of thin precast concrete panels.

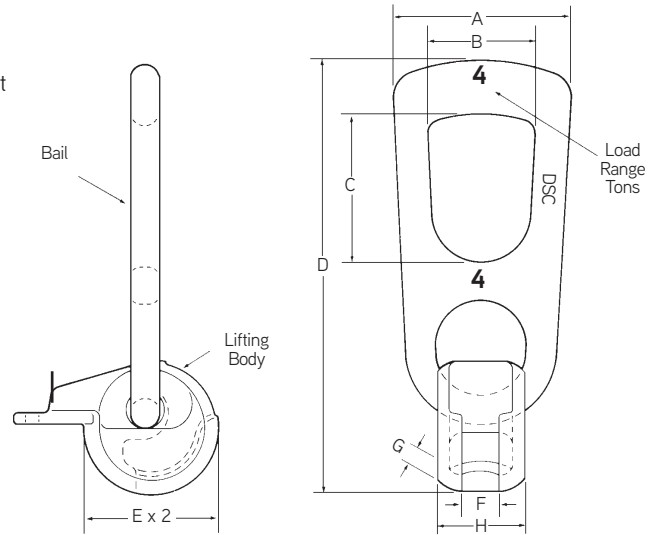

P50 Swift Lift Universal Lifting Eye Dimensions

Rated Load Tons	A	B	C	D	E x 2	H
1	2.9" 74mm	1.7" 43mm	2.8" 71mm	7.5" 190mm	2.20" 56mm	1.26" 32mm
2	3.5" 89mm	2.3" 59mm	3.3" 84mm	9.0" 229mm	2.68" 68mm	1.65" 42mm
4	4.6" 117mm	2.8" 71mm	3.5" 89mm	11.0" 280mm	3.46" 88mm	2.26" 58mm
8	6.3" 160mm	3.3" 84mm	4.4" 112mm	15.6" 397mm	4.40" 112mm	2.90" 74mm
20	7.3" 186mm	4.6" 117mm	5.9" 150mm	20.4" 518mm	5.98" 152mm	4.35" 111mm

The rated load provides a factor of safety of approximately 5 to 1 (ultimate to rated load).

P50 Inspection and Maintenance

The P50 Universal Lifting Eye may be subjected to wear, misuse, overloading and other factors that can affect the lifting eye's rated load. Therefore, it is imperative that the lifting eye be user-inspected at least once a month to determine its general condition and degree of wear.

During the user's monthly inspection, the lifting eye should be checked for evidence of heat application. If evidence of heat application is found, the unit must be scrapped. Check for a bent or twisted bail and discard all units found to have these flaws. Also, check to make certain that the bail rotates freely in all directions.

At least once every three months, dimensions "F" and "G" on each unit should be checked. The upper limits are shown in the chart. If either of these limits is exceeded, the P50 Universal Lifting Eye must be removed from service and destroyed.

The proper method for scrapping a lifting eye is to cut through the bail with a cutting torch to render the unit useless as a lifting device.

No repairs or welding to the P50 Swift Lift Universal Lifting Eye are permitted.

Limiting Dimensions on P50 Swift Lift Universal Lifting Eye

Rated Load (Tons)	F Maximum Width	G Minimum Thickness
1	0.56" 14mm	0.22" 5.6mm
2	0.76" 19mm	0.23" 5.8mm
4	.02" 26mm	0.31" 7.9mm
8	1.31" 33mm	0.47" 12mm
20	1.86" 47mm	0.71" 18mm

Lifting Eye Installation

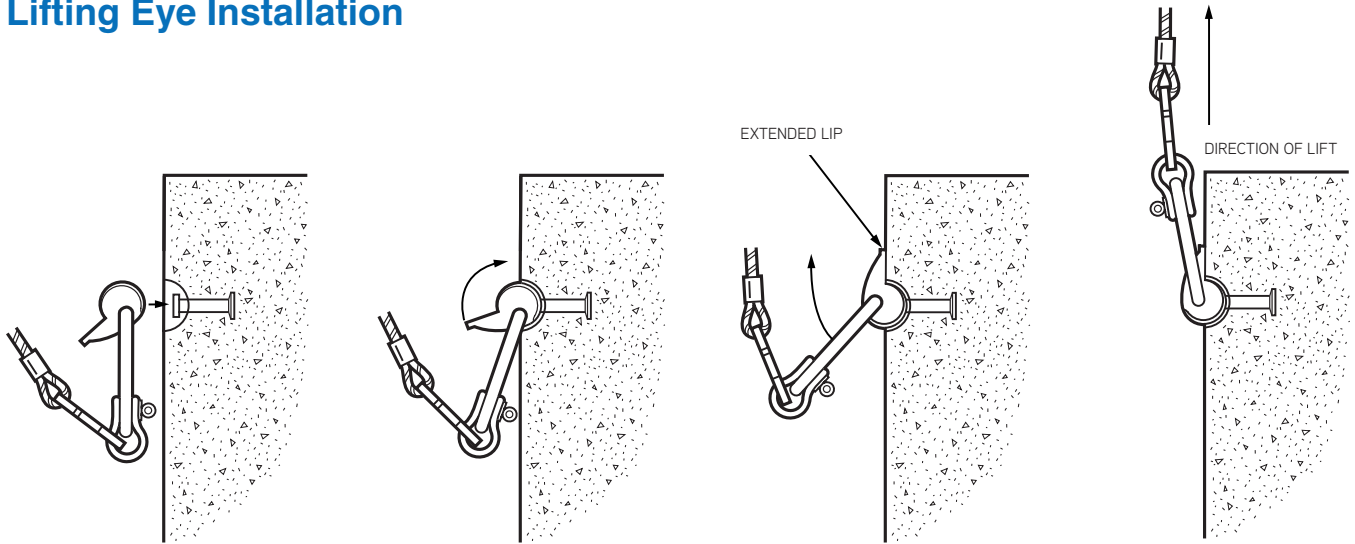

Note: Direction of extended lip should be in the direction of lift.

How to Use the SL Universal Lifting Eye

Note: Load must be applied simultaneous to all Swift Lift Anchors in order to safely lift product.

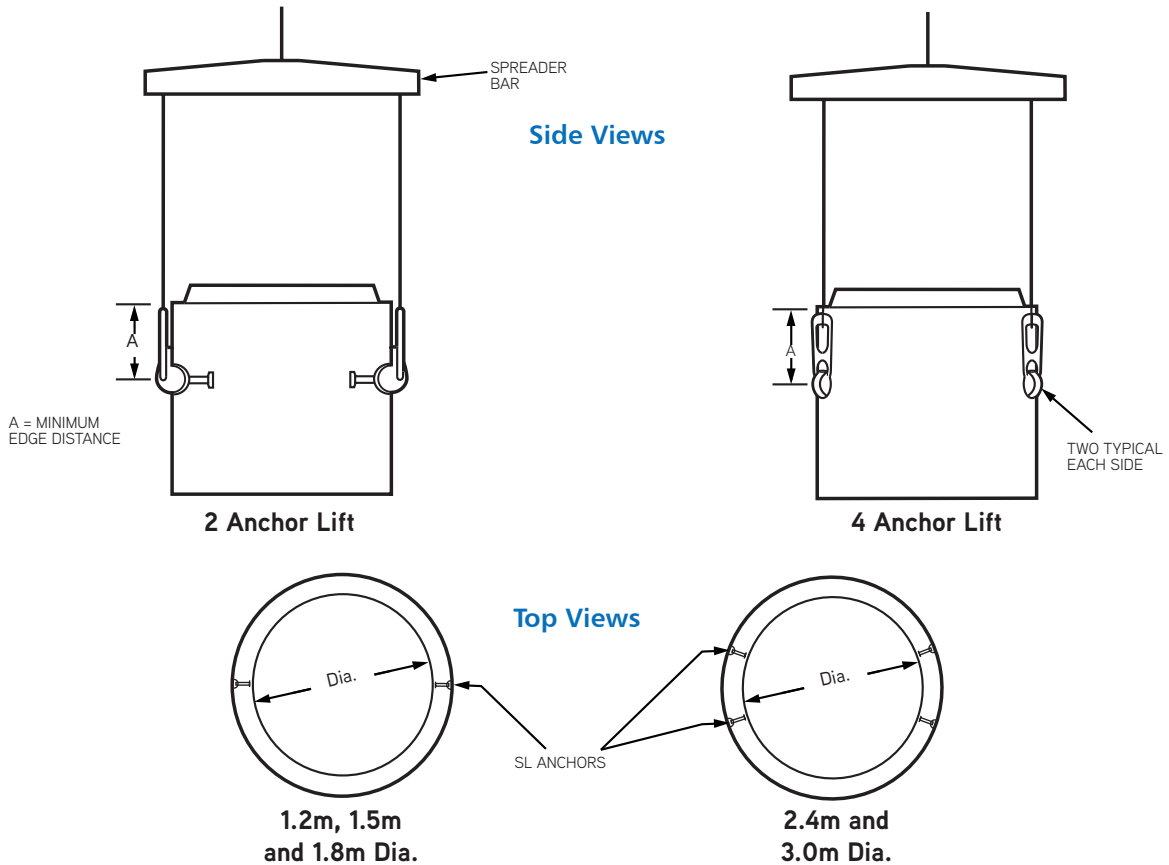

How to Use the SL Universal Lifting Eye

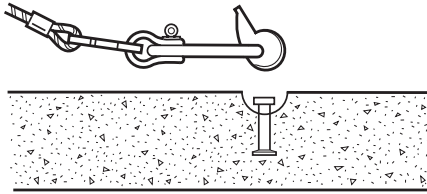

To install the P50 SL Universal Lifting Eye, hold the unit upside down with the T-shaped slot of the body directly over the head of the Swift Lift Anchor.

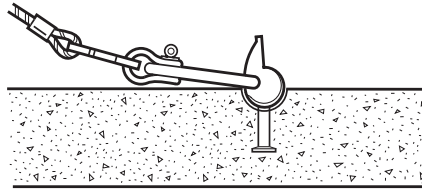

Lower the body of the lifting eye until the T-shaped slot engages the head of the anchor

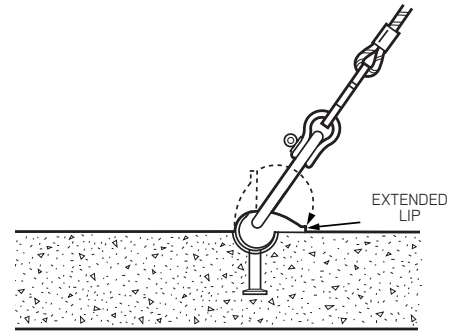

Rotate the body until the extended lip rests on the concrete surface.

Correct Method for Lifting and Placing Pipe

Note: Load must be applied simultaneous to all Swift Lift Anchors in order to safely lift product.

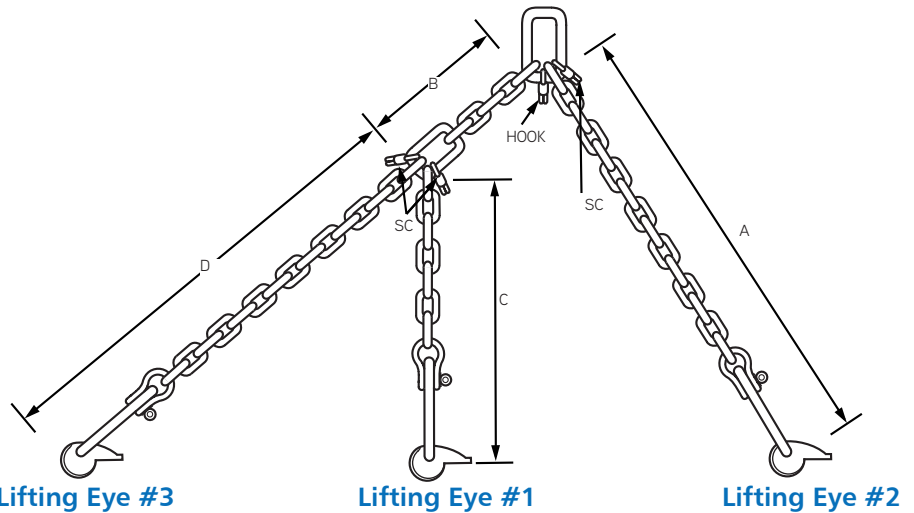
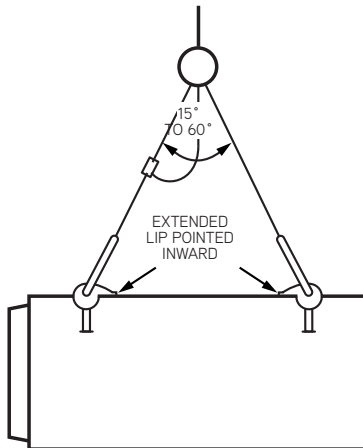

A three-legged chain sling with three P50 SL Universal Lifting Eyes and three shortening clutches (SC) for altering the chain lengths: so constructed that as required, a symmetrical or asymmetrical lifting sling can be made.

Pipe Lengths		A	B	C	D
From	To				
60" (1.5M)	96" (2.5M)	57" (144cm)	16" (40cm)	41" (104cm)	76" (194cm)
96" (2.5M)	138" (3.5M)	75" (190cm)	24" (60cm)	51" (130cm)	110" (280cm)

How to Use SL Universal Lifting Eye for Setting Concrete Pipe

Note: As with lifting any concrete element, special care should be taken by the driver of the placement vehicle to ensure that the impact or dynamic loads are reduced to a minimum. Impact of dynamic loads can greatly overload the anchors and cause failure.

Note: Load must be applied to all anchors simultaneously. The pipe is first transported to the installation site with the symmetrical sling and lowered close to the already placed pipe.

Note: Friction between the sand or gravel fill and the concrete pipe equals 0.4 to 0.5.

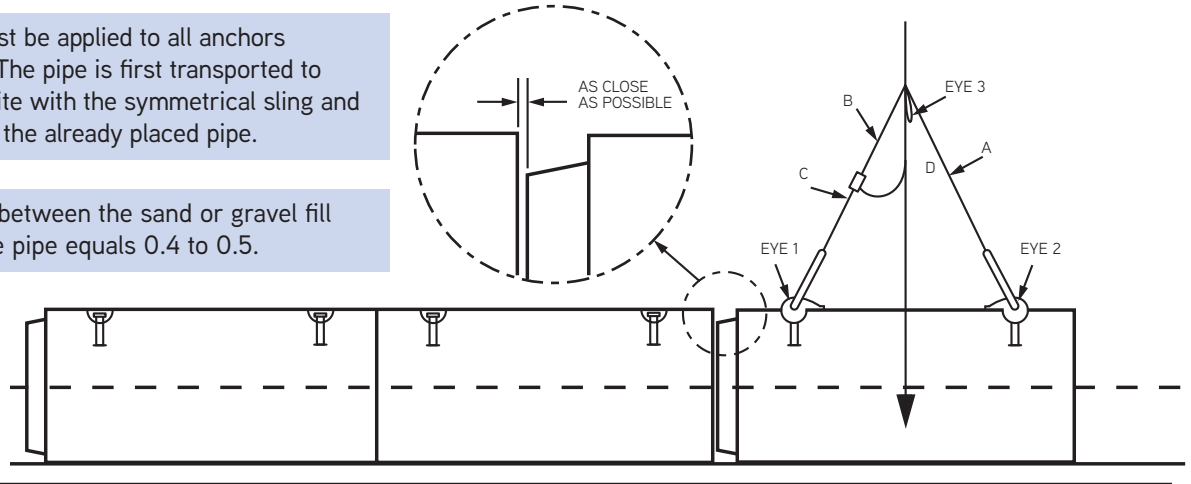

Correct Method for Pulling Pipe Together

To pull the pipe into position, the long leg of the lift sling is coupled to the previously placed pipe. The free short leg (Eye 2) is hung into the hook provided for this purpose.

It must be ensured that the top guide pulley of the crane is over the outer lifting anchor of the previously placed pipe so that the direction of pull is slightly inclined towards the placed pipe.

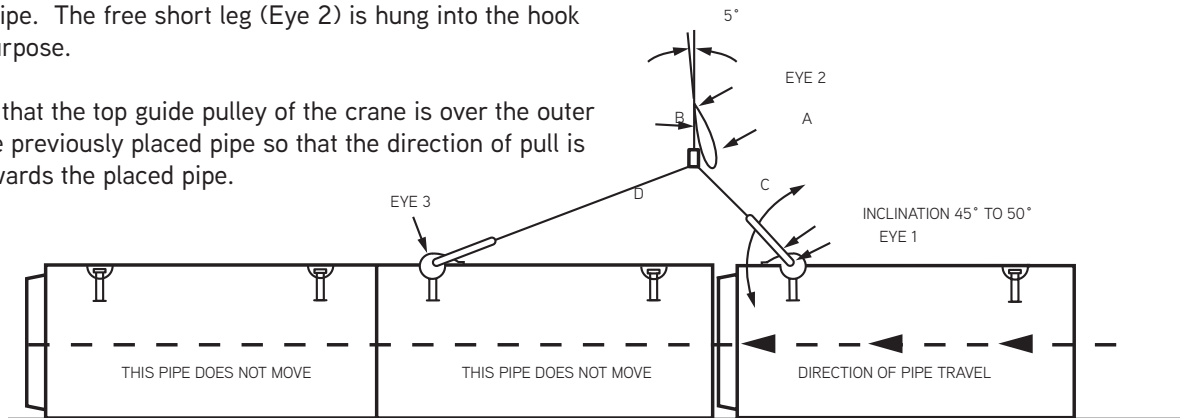

Without moving the jib, the pipe is now pulled into position using the precision hoisting gear.

Warning: The anchors can be overloaded and fail if the crane continues to pull on the sling after the connection is complete.

Stop — release — action complete.

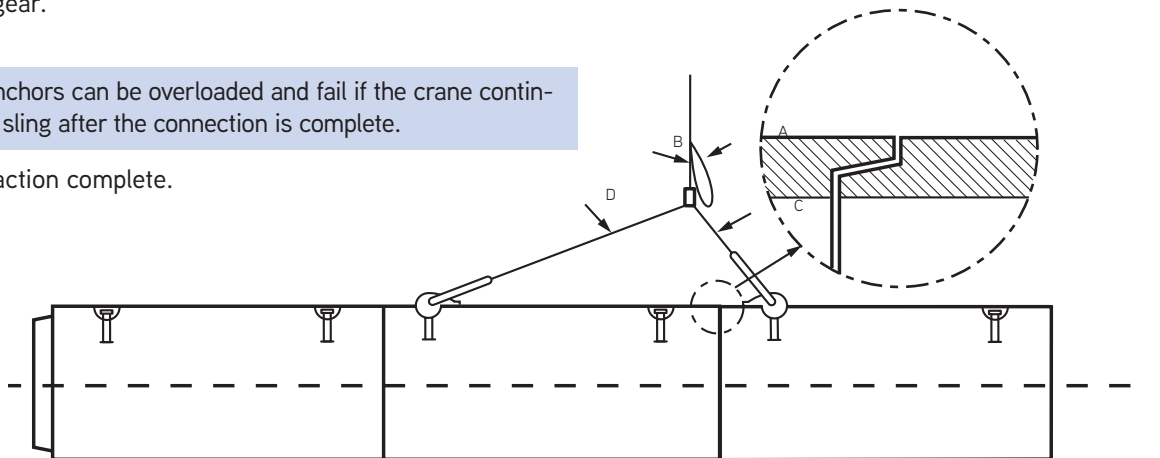

How to Handle and Set Concrete Box Sections

Step 1: Remove form to allow the attachment of lifting eyes to two anchors on each side near the top edge (4 total).

Step 2: Move to desired position.

Step 3: Using two of the top edge anchors, rotate the box section to a horizontal position.

Step 4: Attach lifting eyes to the four anchors and lift and handle as required.

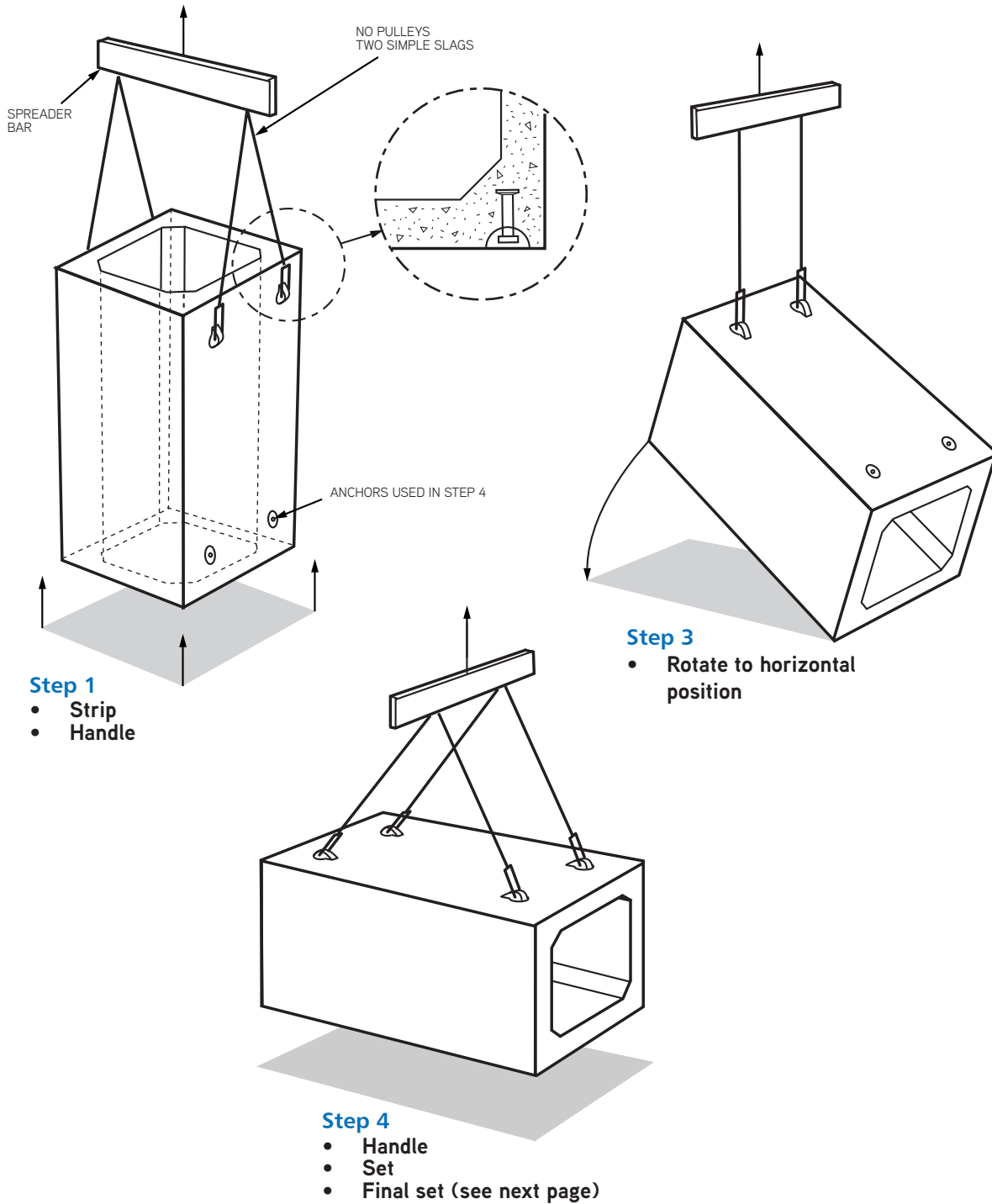

How to Handle and Set Concrete Box Sections, Continued

Note: As with lifting any concrete element, special care should be taken by the driver of the placement vehicle to ensure that the impact or dynamic loads are reduced to a minimum. Impact of dynamic loads can greatly overload the anchors and cause failure.

Note: Load must be applied to all anchors simultaneously.

The pipe is first transported to the installation site with the symmetrical sling and lowered close to the already placed pipe.

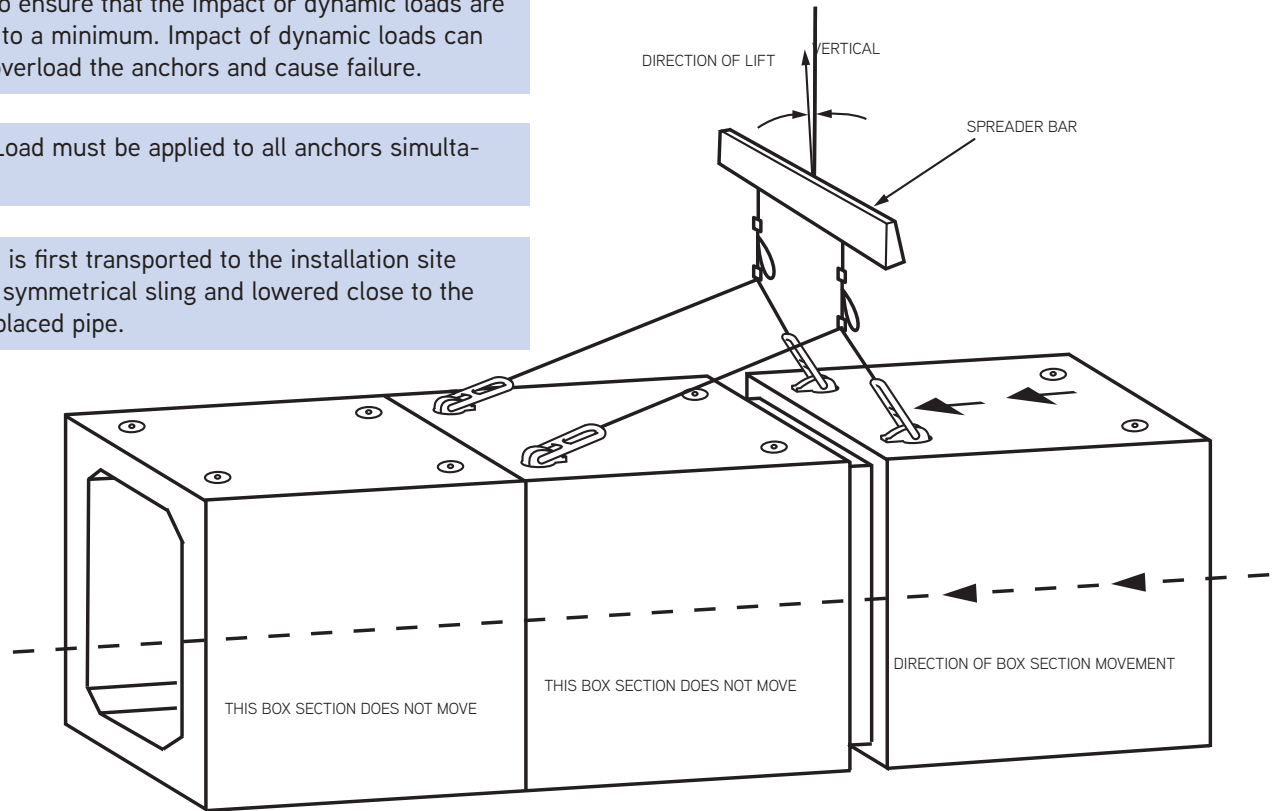

Correct Method for Pulling Box Sections Together

To pull the box section into position, the long leg of the lift sling is coupled to the previously placed box section. The free short leg is hung into the hook provided for this purpose.

It must be ensured that the top guide pulley of the crane is over the outer lifting anchor of the previously placed box section so that the direction of pull is slightly inclined towards the placed box section.

Warning: The anchors can be overloaded and fail if the crane continues to pull on the sling after the connection is complete.

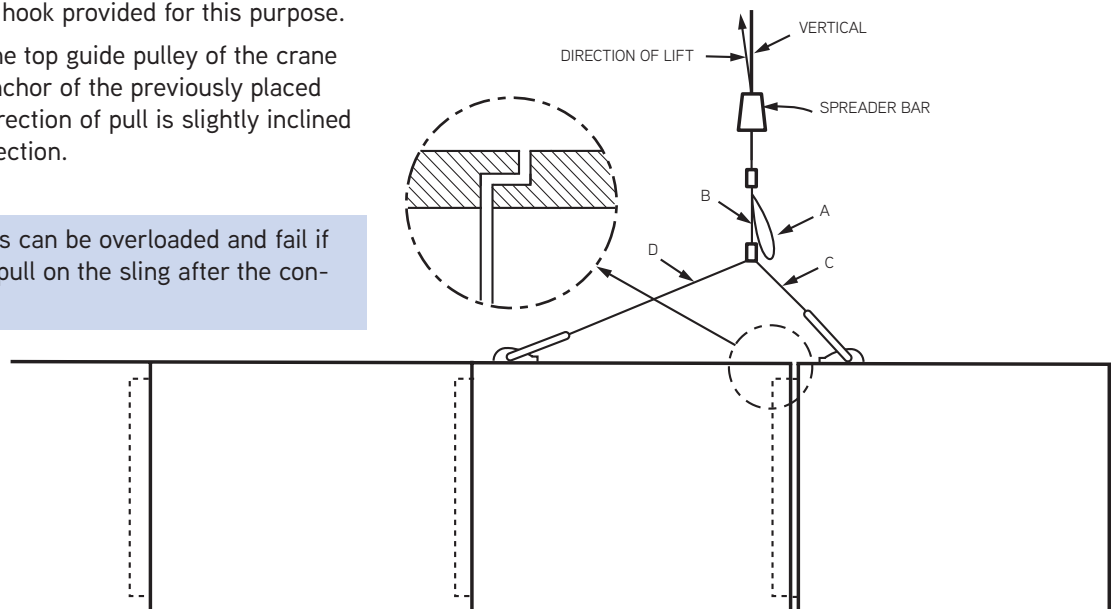

Typical Applications

Median Barrier

- Strip
- Handle
- Set

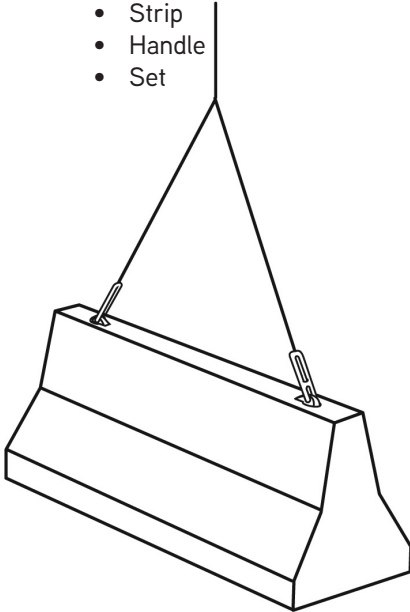

Median Barrier

- Strip
- Handle
- Set

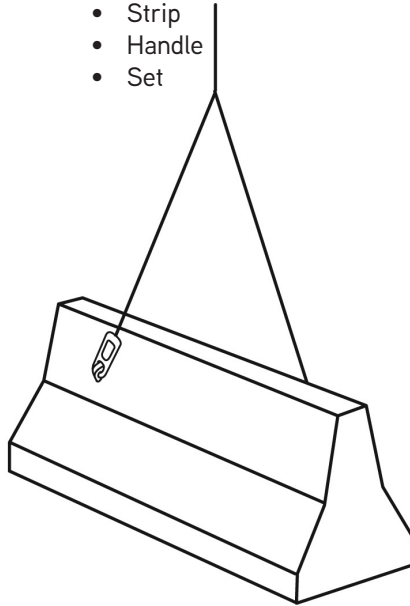

Inlet/Outlet

- Strip
- Handle
- Set

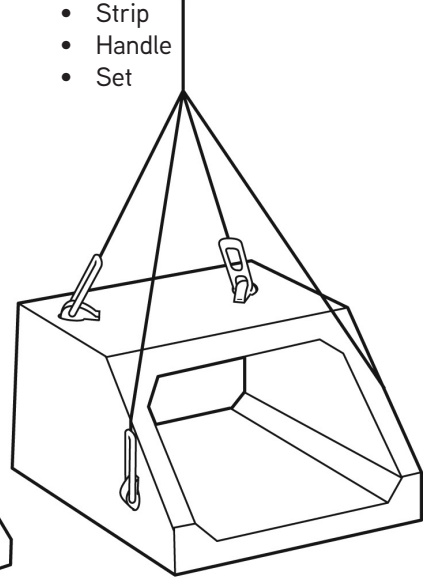

Base/Extension

- Strip
- Lift
- Set

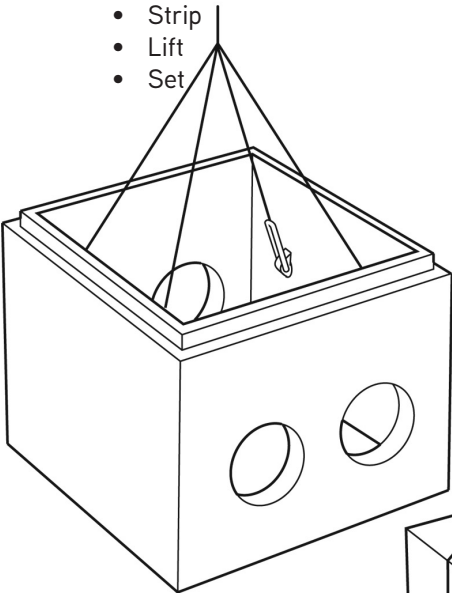

Base/Slab/Lid/Roof

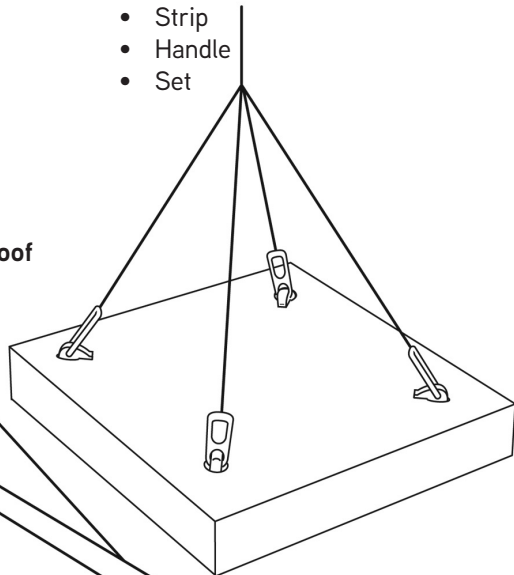

- Strip
- Handle
- Set

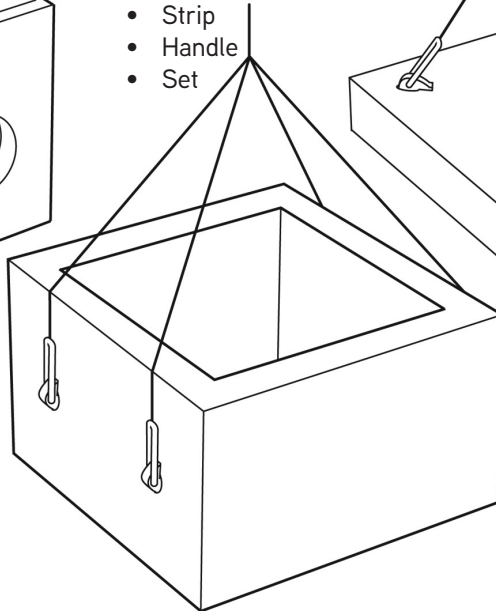

Base/Extension/Roof

- Strip
- Handle
- Set

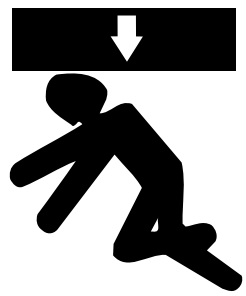

	<div data-bbox="576 247 1468 357" style="background-color: red; color: white; padding: 5px;"> WARNING</div> <div data-bbox="576 357 1468 625" style="padding: 10px;"><p style="text-align: center;">Improper Use of Concrete Forms and Shores Can Cause Severe Injury or Death</p><p>Read, understand and follow the information and instructions in this publication before using any of the Dayton Superior concrete accessories displayed herein. When in doubt about the proper use or installation of any Dayton Superior concrete accessory, immediately contact the nearest Dayton Superior Service Center or Technical Service Department for clarification.</p></div>
---	---

Dayton Superior products are intended for use by trained, qualified and experienced workmen only. Misuse or lack of supervision and/or inspection can contribute to serious accidents or deaths. Any application other than those shown in this publication should be carefully tested before use.

The user of Dayton Superior products must evaluate the product application, determine the safe working load and control all field conditions to prevent applications of loads in excess of a product's safe working load. Safety factors shown in this publication are approximate minimum values. The data used to develop safe working loads for products displayed in this publication are a combination of actual testing and/or other industry sources. Recommended safe working loads given for the products in this publication must never be exceeded.

Worn Working Parts

For safety, concrete forms must be properly used and maintained. Concrete products shown in this publication may be subject to wear, overloading, corrosion, deformation, intentional alteration and other factors that may affect the device's performance. All reusable products must be inspected regularly by the user to determine if they may be used at the rated safe working load or should be removed from service. The frequency of inspections depends upon factors such as (but not limited to) the amount of use, period of service and environment. It is the responsibility of the user to schedule inspections for wear and remove the hardware from service when wear is noted.

Shop or Field Modification

Welding can compromise a product's safe working load value and cause hazardous situations. Knowledge of materials, heat treating and welding procedures is necessary for proper welding. Consult a local welding supply dealer for assistance in determining required welding procedures.

Since Dayton Superior cannot control workmanship or conditions in which modifications are done, Dayton Superior cannot be responsible for any product altered in the field.

Interchangeability

Many concrete products that Dayton Superior manufactures are designed as part of a system. Dayton Superior strongly discourages efforts to interchange products supplied by other manufacturers with components supplied by Dayton Superior. When used properly, and in accordance with published instructions, Dayton Superior products have proven to be among the best designed and safest in the industry. Used improperly or with incompatible components supplied by other manufacturers, Dayton Superior products or systems may be rendered unsafe.

Installation

WARNING

1. Dayton Superior Corporation products shall be installed and used only as indicated on the Dayton Superior Corporation installation guidelines and training materials.
2. Dayton Superior Corporation products must never be used for a purpose other than the purpose for which they were designed or in a manner that exceeds specific load ratings.
3. All instructions are to be completely followed to ensure proper and safe installation and performance
4. Any improper misuse, misapplication, installation, or other failure to follow Dayton Superior Corporation's instruction may cause product malfunction, property damage, serious bodily injury and death.

THE CUSTOMER IS RESPONSIBLE FOR THE FOLLOWING:

1. Conformance to all governing codes
2. Use of appropriate industry standard hardware
3. The integrity of structures to which the products are attached, including their capability to safely accept the loads imposed, as evaluated by a qualified engineer.

SAFETY INSTRUCTIONS:

All governing codes and regulations and those required by the job site must be observed. Always use appropriate safety equipment

Design Changes

Dayton Superior reserves the right to change product designs, rated loads and product dimensions at any time without prior notice.

Note: See Safety Notes and Safety Factor Information.



DAYTON[®]
SUPERIOR

1125 Byers Road
Miamisburg, OH 45342
937-866-0711
888-977-9600

**BUILDING
STRENGTH™**

DS37

01/18

Copyright © 2018 Dayton Superior Corporation, All Rights Reserved.