

## TECHNICAL DATA SHEET

### DESCRIPTION

The P94S Fleet-Lift Forged Anchor is a high-strength, hot forged anchor used for back stripping of precast panels.

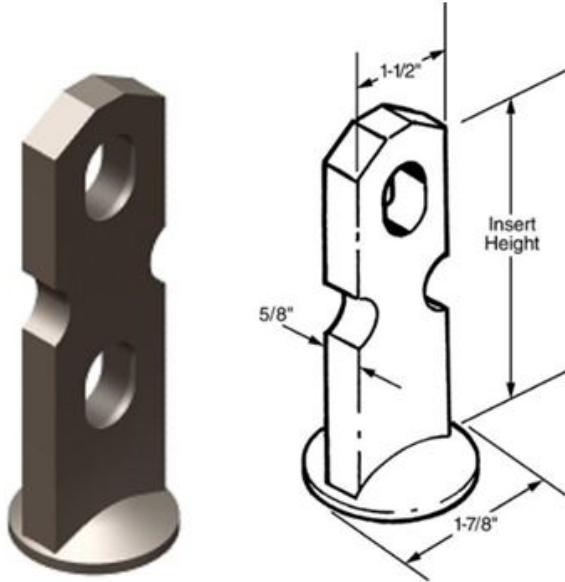

### FEATURES

- Can be “wet set” or used with the Recess Plug
- The P94S may also be used in conjunction with the shear bar to transfer the shear forces in edge lifting applications.
- Available in 2.5, 6 and 10 ton capacities
- Can be used with tension bar to achieve higher tension loads
- Forged anchors do not depend on welding or thread engagement to develop its safe working loads.
- Available in plain or hot dip galvanized finishes.
- Forged material has superior weathering and rain water corrosion resistance when compared to stamped anchors.
- Based on Charpy Impact Test, forged anchors have twice low temperature ductility over stamped anchors.
- Fasten the tension bar tight against the bottom side of the hole.

### TECHNICAL DATA

SWL is based on an ~ fact of safety of 4 to 1 in 3,500 psi normal weight concrete.

Anchor Tonnage	Length (L)	Width (A)	Thickness (B)	Foot Diameter (C)	SWL Tension (lbs)
2.5	3-1/2"	1-5/16"	3/8"	1-1/2"	3,900
2.5	4"	1-5/16"	3/8"	1-1/2"	4,400
6	3-7/8"	1-1/2"	5/8"	1-7/8"	5,000
6	4-1/8"	1-1/2"	5/8"	1-7/8"	5,370
6	4-7/8"	1-1/2"	5/8"	1-7/8"	6,560
6	5-1/8"	1-1/2"	5/8"	1-7/8"	6,970
6	5-7/8"	1-1/2"	5/8"	1-7/8"	8,250
6	6-7/8"	1-1/2"	5/8"	1-7/8"	10,070
10	7"	2-5/8"	3/4"	2-7/8"	12,500

### RELATED PRODUCTS

- P99 Fleet-Lift Reusable Recess Plug
- P99D Fleet-Lift Disposable Recess Plug
- P99P Fleet Patch
- P99C Fleet-Lift Cast Steel Recess Plug
- P98S Fleet-Lift Shear bar
- P98T Tension Bar
- P91S Fleet-Lift Ring Clutch

### HOW TO ORDER

Additional sizes and materials available Made to Order. Please call for availability, lead times and pricing.

### ORDERING INFORMATION

#### FLEET LIFT™ S-ANCHOR

Product Code	Description	Weight
143901	6 TON 3-7/8" HOT DIPPED GALV.	1.03 LB
144993	6 TON 4-1/8" HOT DIPPED GALV.	1.07 LB
142876	6 TON 4-7/8" HOT DIPPED GALV.	1.30 LB
145022	6 TON 5-1/8" HOT DIPPED GALV.	1.38 LB
142875	6 TON 5-7/8" HOT DIPPED GALV.	1.54 LB
100228	6 TON 6-7/8" HOT DIPPED GALV.	1.79 LB
142908	10 TON 7" HOT DIPPED GALV.	3.68 LB

### MANUFACTURER

Dayton Superior Corporation  
 1125 Byers Road  
 Miamisburg, OH 45342  
 Customer Service: 888-977-9600  
 Technical Services: 877-266-7732  
 Website: [www.daytonsuperior.com](http://www.daytonsuperior.com)

**TECHNICAL DATA SHEET****WARRANTY (ACCESSORIES)**

Limited Warranty. Dayton warrants, for a period of 60 days from the date of shipment (three years from the date of shipment in the case of formwork, excluding any consumable Products included with such formwork), that Products and any associated application drawings and engineering services provided by Dayton ("Ancillary Services") will be free from defects in material and workmanship and, in the case of custom designed formwork, that the formwork will meet the specifications set forth in the design drawings approved by Dayton and Customer. Any claim under this warranty must be made in writing within such warranty period. If any Product and/or Ancillary Service covered by a timely claim are found to be defective, Dayton will, within a reasonable time, make any necessary repairs or corrections or, at Dayton's option, replace the Product. Unless pre-authorized by Dayton in writing, Dayton will not accept any charges for correcting defects or accept the return of any Product. This warranty will not apply to any Products that have been subjected to misuse, neglect, storage damage, misapplication, accident or any other damage caused by any person other than Dayton, or that have not been maintained in accordance with Dayton's specifications. THIS LIMITED WARRANTY IS IN LIEU OF ALL OTHER WARRANTIES AS TO THE PRODUCTS AND ANCILLARY SERVICES. DAYTON MAKES NO OTHER WARRANTIES OR GUARANTEES, EXPRESS OR IMPLIED, INCLUDING ANY WARRANTY OF MERCHANTABILITY, FITNESS FOR A PARTICULAR PURPOSE OR OTHERWISE. THE REMEDIES SET FORTH IN THIS SECTION ARE CUSTOMER'S EXCLUSIVE REMEDY FOR BREACH OF WARRANTY.